



LokSeam®

Technical/Installation Information

IMPORTANT NOTICE

READ THIS MANUAL COMPLETELY PRIOR TO BEGINNING THE INSTALLATION OF THE LOKSEAM® ROOFING SYSTEM. MBCI DETAILS MUST BE FOLLOWED AS A MINIMUM TO INSURE APPROPRIATE WARRANTIES WILL BE ISSUED.

ALWAYS INSPECT EACH AND EVERY PANEL AND ALL ACCESSORIES BEFORE INSTALLATION. NEVER INSTALL ANY PRODUCT IF ITS QUALITY IS IN QUESTION. NOTIFY MBCI IMMEDIATELY IF ANY PRODUCT IS BELIEVED TO BE OUT OF TOLERANCE, SPECIFICATION OR HAS BEEN DAMAGED DURING SHIPMENT.

IF THERE IS A CONFLICT BETWEEN PROJECT ERECTION DRAWINGS PROVIDED OR APPROVED BY MBCI AND DETAILS IN THIS MANUAL, PROJECT ERECTION DRAWINGS WILL TAKE PRECEDENCE.

Ice Dam Disclaimer

MBCI designs its standing seam roofs to meet the load requirements dictated by governing codes and project specifications, including applicable snow loads. However, NCI expressly disclaims responsibility for weathertightness or roof point loading issues or other hazards resulting from ice dam situations. Any time ice and snow can melt on the main body of the roof and refreeze at the eave or in the shadow of an adjacent wall, an ice dam situation may develop. In addition to local climate, ice dam formation is affected by many other factors, including but not limited to, roof insulation R value, roof panel color, interior temperature of building, heater location in building, eave overhangs, parapet walls, shading of building roof areas from adjacent trees, parapets, buildings, etc. These factors are design and maintenance issues and are outside the control of NCI. NCI specifically disclaims any liability for damage due to ice dam formation, although the following issues should be taken into consideration concerning standing seam roofs installed in freezing climates:

- Always use field seamed panels. These machine-folded seams are more durable when subjected to occasional icing.
- Eliminate “cold” eave overhangs and parapet walls from the building design. Roof overhangs outside the heated envelope of the building will tend to be colder than the roof areas over the heated envelope. Simple roof designs are preferred. Parapet walls at the eave allow ice and snow to collect due to shading effects and the lower roof temperatures caused thereby.
- Make sure the interior of the building is adequately insulated and the heating is properly distributed. Inadequate insulation in the roof and/or improper heat distribution causes heat flow through the main body of the roof. On days when the temperature is below freezing, this heat gain can cause ice and snow to melt and refreeze at the eave where the roof is colder.
- Lay out the building to prevent the eaves and other roof areas from being shaded during the winter. This may mean eliminating adjacent trees or reconsidering roof geometries.
- Consider using self-regulating heating cables at the eaves to mitigate the effects of ice dams.
- On building designs using attics, over-insulate the attic floor and provide adequate ventilation in the attic. This will reduce heat transfer through the roof resulting in more consistent roof temperatures between eave and field of roof.
- Increase the degree of diligence with respect to underlayment materials at roof areas prone to icing. This may include valleys, eaves, dormers and roof areas near dormers, parapets and the like where shading may occur.

For more information on this subject, please refer to the MCA's Metal Roof Design For Cold Climates manual.

The Engineering data contained herein is for the expressed use of customers and design professionals. Along with this data, it is recommended that the design professional have a copy of the most current version of the North American Specification for the Design of Cold-Formed Steel Structural Members published by the American Iron and Steel Institute to facilitate design. This Specification contains the design criteria for cold-formed steel components. Along with the Specification, the designer should reference the most current building code applicable to the project jobsite in order to determine environmental loads. If further information or guidance regarding cold-formed design practices is desired, please contact the manufacturer.

Descriptions and specifications contained herein were in effect at the time this publication was approved for printing. In a continuing effort to refine and improve products, MBCI reserves the right to discontinue products at any time or change specifications and/or designs without incurring obligation. **To ensure you have the latest information available, please inquire or visit our website at mbc.com.** Application details are for illustration purposes only and may not be appropriate for all environmental conditions, building designs or panel profiles. Projects should be designed to conform to applicable building codes, regulations and accepted industry practices. If there is a conflict between this manual and project erection drawings, the erection drawings will take precedence.

TABLE OF CONTENTS

ROOFING SYSTEM

General Description	LS-5
Architect/Engineering Information	LS-6

ENGINEERING

UL 90 Requirements	LS-7
18" Properties/Load Tables	LS-8 - LS-9
16" Properties/Load Tables	LS-10 - LS-11
12" Properties/Load Tables	LS-12 - LS-13

SPECIFICATIONS

Specifications For Metal Roofing	LS-14 - LS-20
--	---------------

GENERAL INFORMATION

Product Checklist	LS-21 - LS-25
Ordering Information	LS-26
Preparatory Requirements	LS-27
Unloading	LS-28 - LS-29
Handling/Panel Storage	LS-30

DETAILS

Special Erection Techniques	
Roof Curb Installation	LS-31 - LS-34
Field Hemming Panel End	LS-35
Panel	LS-36

Details Over Purlins	
Endlap	LS-37
Hip	LS-38
Ridge	LS-39
Vented Ridge	LS-40
Floating Valley	LS-41
Fixed Valley	LS-42
High Eave	LS-43
Floating Eave with Eave Trim	LS-44
Fixed Eave with Eave Trim	LS-45
Floating Eave with Gutter	LS-46
Fixed Eave with Gutter	LS-47
Snow Gutter	LS-48
Floating Rake	LS-49
Parapet High Eave	LS-50
Floating Parapet Rake	LS-51
Roof Transition	LS-52

Details Over Wood Deck	
Endlap	LS-53
Hip	LS-54
Fixed Ridge	LS-55
Floating Ridge	LS-56
Vented Ridge	LS-57
Floating Valley	LS-58
Fixed Valley	LS-59
High Eave	LS-60
Floating Eave with Eave Trim	LS-61
Fixed Eave with Eave Trim	LS-62
Floating Eave with Gutter	LS-63
Fixed Eave with Gutter	LS-64
Floating Rake	LS-65
Fixed Rake	LS-66
Floating Parapet High Eave	LS-67
Fixed Parapet High Eave	LS-68
Floating Parapet Rake	LS-69
Fixed Parapet Rake	LS-70
Roof Transition	LS-71



TABLE OF CONTENTS

DETAILS CONTINUED

Details Over Metal Deck

Rigid Board Insulation Over Metal Deck.....	LS-72
Endlap.....	LS-73
Fixed Ridge.....	LS-74
Vented Ridge.....	LS-75
Floating Valley.....	LS-76
Fixed High Eave.....	LS-77
Floating Eave with Eave Trim.....	LS-78
Floating Eave with Gutter.....	LS-79
Floating Rake.....	LS-80
Fixed Parapet High Eave.....	LS-81
Floating Parapet High Eave.....	LS-82

ROOFING SYSTEM

GENERAL DESCRIPTION

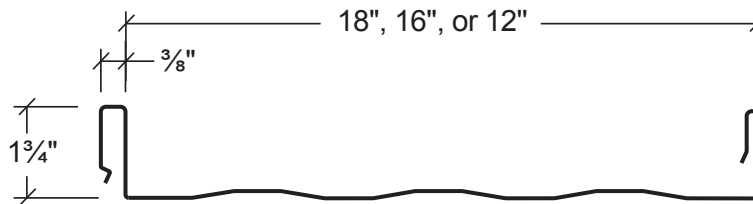

Coverage Widths - 18", 16" or 12"

Minimum Slope - 3:12

Panel Attachment - Standard and UL 90 Clips (concealed fastening systems)

Panel Substrate - Galvalume® (standard)

Gauge - Standard: 24 (18", 16", 12" widths); Optional: 22 (18", 16", 12" widths), 26 (12" width only)

Finishes - Striated (standard)* or Embossed Striated

Coatings - Signature® 200, Signature® 300, Signature® 300 Metallic

PRODUCT SELECTION CHART

PRODUCT	Signature® 300 Metallic			Signature® 300			Signature® 200			Galvalume Plus®		
	26-Ga.	24Ga.	22-Ga.	26-Ga.	24Ga.	22-Ga.	26-Ga.	24Ga.	22-Ga.	26-Ga.	24Ga.	22-Ga.
LokSeam®												
12" Wide	■	■	■	■	■	■	■	■	■	●	●	■
16" Wide		●	■		●	■		●	■		●	●
18" Wide		●	■		●	■		●	■		●	●

Signature® is a registered trademark of NCI Group, Inc. Galvalume Plus® is a registered trademark of BIEC International.

- — Available in any quantity.
- — Minimum quantity may be required.

Other colors, finishes, gauges, and materials available; please inquire.

* Striated panels are standard to reduce "oil canning".

ROOFING SYSTEM

ARCHITECT/ENGINEER INFORMATION

1. **LokSeam®** is a snap-together, integral batten roof system, available in three widths: 18", 16", and 12". Factory applied mastic inside of female leg of panel is standard.
2. The minimum recommended slope is 3:12. For slopes less than 3:12, call MBCI.
3. **LokSeam®** is a UL 90 rated, structural roofing panel. This panel can be installed directly over purlins or bar joists. It does not require a solid substructure for support (Caution: See Note 14).
4. Watertight and aesthetically pleasing endlaps may be accomplished through the use of swaged and prepunched panels (16" panels can be swaged but not punched). MBCI recommends the use of prepunched back-up plates at the endlap for weathertightness. Prepunching of the panels is available for the endlap condition only. **(Swaged endlaps require the roof erection to proceed from left to right as viewed from the eave looking toward the ridge.)** Roofs with no endlaps may be erected from either direction. For panel lengths over 40', please inquire. When using an alternate endlap detail as shown on **Pages LS-37 and LS-53** do not order panels with prepunched endlaps.
5. Panels can be installed on roofs with a transition by using MBCI's die-formed rib covers.
6. Narrower widths, heavier gauges, striations and embossing minimize oil canning. Industry standard is 18" wide, 24-gauge. Oil canning is not a cause for rejection.
7. The substructure (eave to ridge) must be on plane with a tolerance of ¼" in 20' and ⅜" in 40'.
8. All panels require end sealant at eave and valley conditions; however, for illustration purposes, this sealant is not shown on all drawings. See **Page LS-36** for panel end sealant detail.
9. For proper fastener application, see **Pages LS-24 and LS-25**.
10. All drawings and trim dimensions in this manual are based on a 1¼" wall thickness ("R" Panel) and a slope of 3:12. Other wall panel thicknesses as well as roof slopes may affect various dimensions on drawings and trim. If you have any questions, call MBCI.
11. **The information in this manual is believed to be correct and accurate. It should not be used for any specific application without being reviewed by a registered professional engineer. All metal roofs should be designed by a registered, professional engineer for loads specified by the governing code, including the higher pressures encountered at the edge zones of the roof.**
12. **Avoid restricting the thermal expansion and contraction of the LokSeam® panels. (ie: Do not attach panels to the substructure at both the eave and ridge.)**
13. **LokSeam® panels are not designed to be work platforms.** Avoid any unnecessary foot traffic on **LokSeam®** panels. If foot traffic is required, protect the roof panels by using some type of roof pad, temporary deck, or walkway.
14. **When installing LokSeam® panels over open framing with blanket insulation: (A) install insulation parallel to purlins or joists, or (B) install insulation across purlins or joists and compress it with pinch bars. (¼" thick radiant barrier insulation may be used as an alternative to blanket insulation.)**

WARNING

As with all standing seam roof systems, sound attenuation (example: blanket insulation) should be installed between the panels and open framing, such as purlins or joists, to prevent "roof rumble" during windy conditions.

Applications over solid deck such as rigid insulation over a metal deck or a wood deck may require additional acoustical consideration to ensure that thermal vibration noises are isolated from the building interior. This is especially important if the bottom of the deck is left open to the interior, in cathedral ceiling applications or when the attic space is used as a return air plenum.

A vapor retarder may be necessary to protect roofing components when high humidity is a factor. The need for a vapor retarder, as well as the type, placement and location should be determined by an architect or engineer. The following are examples of conditions that may require a vapor retarder: (A) a project where outside winter temperatures below 40 degrees F. are anticipated and where average winter interior relative humidity of 45% or greater is expected. (B) building usages with high humidity interiors such as indoor swimming pools, textile manufacturing operations, food, paper or other wet-process industrial plants. (C) Construction elements that may release moisture after the roof is installed, such as interior concrete, masonry or plaster work and fuel burning heaters.

CAUTION

Diaphragm capabilities and purlin stability are not provided by MBCI's **LokSeam®** roof system. Therefore, other bracing may be required to conform to A.I.S.C. or A.I.S.I. specifications.

ENGINEERING

UNDERWRITERS LABORATORIES APPROVAL

Construction Number	Panel Width (in.)	Gauge	Clip Type	Clip Spacing	Substrate	UL-2218 Impact Resistance	UL-263 Fire Rating	UL-580 Rating
254	12"	22 min.	UL 90	5'-0"	Open Framing	Class 4	Class A	Class 90
254	12"	24 min.	UL 90	4'-0"	Open Framing	Class 4	Class A	Class 90
255	18" max.	24 min.	UL 90	4'-0"	Open Framing	Class 4	Class A	Class 90
303	18" max.	24 min.	UL 90	4'-0"	Composite System	Class 4	Class A	Class 90
342	18" max.	24 min.	UL 90	4'-0"	Composite System	Class 4	Class A	Class 90
343	18" max.	24 min.	UL 90	3'-0"	Plywood	Class 4	Class A	Class 90
414	18" max.	24 min.	UL 90	3'-0"	Plywood	Class 4	Class A	Class 90
436	18" max.	24 min.	UL 90	4'-0"	Plywood	Class 4	Class A	Class 90
445	12"	22 min.	UL 90	5'-0"	Open Framing	Class 4	Class A	Class 90
445	12"	24 min.	UL 90	4'-0"	Open Framing	Class 4	Class A	Class 90
446	18" max.	24 min.	UL 90	4'-0"	Open Framing	Class 4	Class A	Class 90
448	18" max.	24 min.	UL 90	4'-0"	Composite System	Class 4	Class A	Class 90
486	18" max.	24 min.	UL 90	4'-0"	Composite System	Class 4	Class A	Class 90
508A	18" max	24 min.	UL 90	3'-0"	Composite System	Class 4	Class A	Class 90
543	12" max.	22 min.	UL 90	5'-0"	Open Framing	Class 4	Class A	Class 90
543	18" max.	24 min.	UL 90	4'-0"	Open Framing	Class 4	Class A	Class 90
544	18" max.	24 min.	UL 90	4'-0"	Composite System	Class 4	Class A	Class 90

NOTES

1. Wind uplift test procedures are in accordance with Underwriters Laboratories Standard UL-580 under "Tests For Uplift Resistance of Roof Assemblies".
2. A detailed installation method is available for each Construction Number above and can be found in the UL Roofing Materials and Systems Directory. The panels must be installed in a certain manner to achieve the published results.
3. The panel qualifies for a Class A fire rating in compliance with Underwriters Laboratories Standard UL-263.
4. The panel system is listed under following Fire Resistance Design Numbers: P225, P227, P230, P237, P265, P268, P508, P510, P512, P701, P711, P720, P722, P726, P731, P734, P801, P815, and P819. Refer to the UL Fire Resistance Directory for specific construction methods and hourly ratings.
5. LokSeam® panels carry a Class 4 rating under UL-2218 "Test Standard For Impact Resistance".

FLORIDA BUILDING CODE PRODUCT APPROVAL

LokSeam® Roofing System details and engineering load tables have been examined by the State of Florida and comply with the 5th Edition (2014) Florida Building Code Product Approval Number (FL#11819.3).

ENGINEERING

LokSeam® PANEL

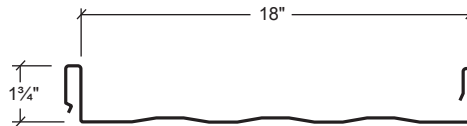

SECTION PROPERTIES								
			NEGATIVE BENDING			POSITIVE BENDING		
PANEL	F _y	WEIGHT	I _{xe}	S _{xe}	Maxo	I _{xe}	S _{xe}	Maxo
GAUGE	(KSI)	(PSF)	(IN. 4/FT)	(IN. 3/FT)	(KIP-IN)	(IN. 4/FT)	(IN. 3/FT)	(KIP-IN)
24	50	1.25	0.0321	0.0403	1.2066	0.0682	0.0465	1.3912
22	50	1.60	0.0446	0.0594	1.7795	0.0957	0.0655	1.9620

NOTES

1. All calculations for the properties of **LokSeam®** panels are calculated in accordance with the 2012 edition of the North American Specification for Design of Cold-Formed Steel Structural Members.
2. I_{xe} is for deflection determination.
3. S_{xe} is for bending.
4. Maxo is allowable bending moment.
5. All values are for one foot of panel width.

The engineering data contained herein is for the expressed use of customers and design professionals. Along with this data, it is recommended that the design professional have a copy of the most current version of the *North American Specification for the Design of Cold-Formed Steel Structural Members* published by the American Iron and Steel Institute to facilitate design. This Specification contains the design criteria for cold-formed steel components. Along with the Specification, the designer should reference the most current building code applicable to the project job site in order to determine environmental loads. If further information or guidance regarding cold-formed design practices is desired, please contact the manufacturer.

ENGINEERING

LokSeam® PANEL

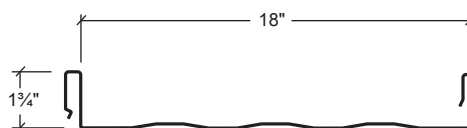

ALLOWABLE UNIFORM LOADS IN POUNDS PER SQUARE FOOT

24- Gauge (Fy = 50 KSI)								
SPAN TYPE	LOAD TYPE	SPAN IN FEET						
		2.5	3.0	3.5	4.0	4.5	5.0	5.5
SINGLE	LIVE LOAD	148.4	103.1	75.7	58.0	45.8	37.1	30.7
2-SPAN	LIVE LOAD	128.7	89.4	65.7	50.3	39.7	32.2	26.6
3-SPAN	LIVE LOAD	160.9	111.7	82.1	62.8	49.7	40.2	33.2
4-SPAN	LIVE LOAD	150.2	104.3	76.6	58.7	46.4	37.6	31.0

22- Gauge (Fy = 50 KSI)								
SPAN TYPE	LOAD TYPE	SPAN IN FEET						
		2.5	3.0	3.5	4.0	4.5	5.0	5.5
SINGLE	LIVE LOAD	200.0	145.3	106.8	81.8	64.6	52.3	43.2
2-SPAN	LIVE LOAD	189.8	131.8	96.8	74.1	58.6	47.5	39.2
3-SPAN	LIVE LOAD	200.0	164.8	121.1	92.7	73.2	59.3	49.0
4-SPAN	LIVE LOAD	200.0	153.8	113.0	86.5	68.4	55.4	45.8

NOTES:

1. THE ABOVE LOADS ARE NOT FOR USE WHEN DESIGNING PANELS TO RESIST WIND UPLIFT.
2. Strength calculations based on the 2012 AISI Standard *North American Specification for the Design of Cold-Formed Steel Structural Members*.
3. Allowable loads are applicable for uniform loading and spans without overhangs.
4. LIVE load capacities are for those loads that push the panel against its supports. The applicable limit states are flexure, shear, combined shear and flexure, web crippling at end and interior supports, and a deflection limit of L/180 under strength-level loads.
5. Panel pullover and screw pullout capacity must be checked separately using the screws employed for each particular application when utilizing this load chart.
6. The use of any field seaming equipment or accessories including but not limited to clips, fasteners, and support plates (eave, backup, rake, etc.) other than that provided by the manufacturer may damage panels, void all warranties and will void all engineering data.
7. This material is subject to change without notice. Please contact MBCI for the most current data.

The engineering data contained herein is for the expressed use of customers and design professionals. Along with this data, it is recommended that the design professional have a copy of the most current version of the *North American Specification for the Design of Cold-Formed Steel Structural Members* published by the American Iron and Steel Institute to facilitate design. This Specification contains the design criteria for cold-formed steel components. Along with the Specification, the designer should reference the most current building code applicable to the project jobsite in order to determine environmental loads. If further information or guidance regarding cold-formed design practices is desired, please contact the manufacturer.

ENGINEERING

LokSeam® PANEL

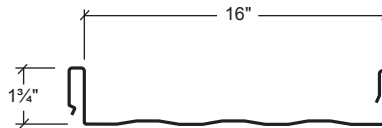

SECTION PROPERTIES								
			NEGATIVE BENDING			POSITIVE BENDING		
PANEL	F _y	WEIGHT	l _{xe}	S _{xe}	Maxo	l _{xe}	S _{xe}	Maxo
GAUGE	(KSI)	(PSF)	(IN. 4/FT)	(IN. 3/FT)	(KIP-IN)	(IN. 4/FT)	(IN. 3/FT)	(KIP-IN)
24	50	1.34	0.0361	0.0452	1.3527	0.0758	0.0520	1.5570
22	50	1.71	0.0500	0.0666	1.9938	0.1052	0.0731	2.1921

NOTES

1. All calculations for the properties of **LokSeam®** panels are calculated in accordance with the 2012 edition of the North American Specification for Design of Cold-Formed Steel Structural Members.
2. l_{xe} is for deflection determination.
3. S_{xe} is for bending.
4. Maxo is allowable bending moment.
5. All values are for one foot of panel width.

The engineering data contained herein is for the expressed use of customers and design professionals. Along with this data, it is recommended that the design professional have a copy of the most current version of the *North American Specification for the Design of Cold-Formed Steel Structural Members* published by the American Iron and Steel Institute to facilitate design. This Specification contains the design criteria for cold-formed steel components. Along with the Specification, the designer should reference the most current building code applicable to the project jobsite in order to determine environmental loads. If further information or guidance regarding cold-formed design practices is desired, please contact the manufacturer.

ENGINEERING

LokSeam® PANEL

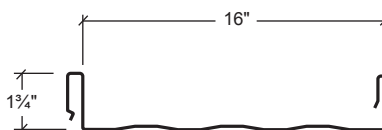

ALLOWABLE UNIFORM LOADS IN POUNDS PER SQUARE FOOT

24- Gauge (Fy = 50 KSI)								
SPAN TYPE	LOAD TYPE	SPAN IN FEET						
		2.5	3.0	3.5	4.0	4.5	5.0	5.5
SINGLE	LIVE LOAD	166.1	115.3	84.7	64.9	51.3	41.5	34.4
2-SPAN	LIVE LOAD	144.8	100.5	73.9	56.6	44.7	36.2	29.8
3-SPAN	LIVE LOAD	181.0	125.7	92.3	70.7	55.9	45.2	37.4
4-SPAN	LIVE LOAD	169.0	117.3	86.2	66.0	52.1	42.2	34.9

22- Gauge (Fy = 50 KSI)								
SPAN TYPE	LOAD TYPE	SPAN IN FEET						
		2.5	3.0	3.5	4.0	4.5	5.0	5.5
SINGLE	LIVE LOAD	200.0	162.4	119.3	91.3	72.2	58.5	48.3
2-SPAN	LIVE LOAD	200.0	147.7	108.5	83.1	65.6	53.2	43.9
3-SPAN	LIVE LOAD	200.0	184.6	135.6	103.8	82.0	66.5	54.9
4-SPAN	LIVE LOAD	200.0	172.4	126.6	97.0	76.6	62.1	51.3

NOTES:

1. **THE ABOVE LOADS ARE NOT FOR USE WHEN DESIGNING PANELS TO RESIST WIND UPLIFT.**
2. Strength calculations based on the 2012 AISI Standard *North American Specification for the Design of Cold-Formed Steel Structural Members*.
3. Allowable loads are applicable for uniform loading and spans without overhangs.
4. LIVE load capacities are for those loads that push the panel against its supports. The applicable limit states are flexure, shear, combined shear and flexure, web crippling at end and interior supports, and a deflection limit of L/180 under strength-level loads.
5. Panel pullover and screw pullout capacity must be checked separately using the screws employed for each particular application when utilizing this load chart.
6. The use of any field seaming equipment or accessories including but not limited to clips, fasteners, and support plates (eave, backup, rake, etc.) other than that provided by the manufacturer may damage panels, void all warranties and will void all engineering data.
7. This material is subject to change without notice. Please contact MBCI for the most current data.

The engineering data contained herein is for the expressed use of customers and design professionals. Along with this data, it is recommended that the design professional have a copy of the most current version of the *North American Specification for the Design of Cold-Formed Steel Structural Members* published by the American Iron and Steel Institute to facilitate design. This Specification contains the design criteria for cold-formed steel components. Along with the Specification, the designer should reference the most current building code applicable to the project jobsite in order to determine environmental loads. If further information or guidance regarding cold-formed design practices is desired, please contact the manufacturer.

ENGINEERING

LokSeam® PANEL

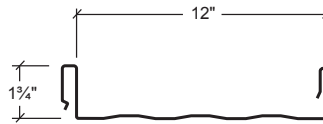

SECTION PROPERTIES								
			NEGATIVE BENDING			POSITIVE BENDING		
PANEL	F _y	WEIGHT	I _{xe}	S _{xe}	Max _o	I _{xe}	S _{xe}	Max _o
GAUGE	(KSI)	(PSF)	(IN. 4/FT)	(IN. 3/FT)	(KIP-IN)	(IN. 4/FT)	(IN. 3/FT)	(KIP-IN)
24	50	1.41	0.0472	0.0597	1.7888	0.0953	0.0682	2.0429
22	50	1.81	0.0663	0.0878	2.6292	0.1313	0.0954	2.8577

NOTES

1. All calculations for the properties of **LokSeam®** panels are calculated in accordance with the 2012 edition of the North American Specification for Design of Cold-Formed Steel Structural Members.
2. I_{xe} is for deflection determination.
3. S_{xe} is for bending.
4. Max_o is allowable bending moment.
5. All values are for one foot of panel width.

The engineering data contained herein is for the expressed use of customers and design professionals. Along with this data, it is recommended that the design professional have a copy of the most current version of the *North American Specification for the Design of Cold-Formed Steel Structural Members* published by the American Iron and Steel Institute to facilitate design. This Specification contains the design criteria for cold-formed steel components. Along with the Specification, the designer should reference the most current building code applicable to the project jobsite in order to determine environmental loads. If further information or guidance regarding cold-formed design practices is desired, please contact the manufacturer.

ENGINEERING

LokSeam® PANEL

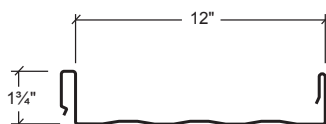

ALLOWABLE UNIFORM LOADS IN POUNDS PER SQUARE FOOT

24- Gauge (Fy = 50 KSI)								
SPAN TYPE	LOAD TYPE	SPAN IN FEET						
		2.5	3.0	3.5	4.0	4.5	5.0	5.5
SINGLE	LIVE LOAD	200.0	151.3	111.2	85.1	67.3	54.5	45.0
2-SPAN	LIVE LOAD	190.8	132.5	97.3	74.5	58.9	47.7	39.4
3-SPAN	LIVE LOAD	200.0	165.5	121.7	93.2	73.6	59.6	49.3
4-SPAN	LIVE LOAD	200.0	154.6	113.6	87.0	68.7	55.7	46.0

22- Gauge (Fy = 50 KSI)								
SPAN TYPE	LOAD TYPE	SPAN IN FEET						
		2.5	3.0	3.5	4.0	4.5	5.0	5.5
SINGLE	LIVE LOAD	200.0	200.0	155.5	119.1	94.1	76.2	63.0
2-SPAN	LIVE LOAD	200.0	194.8	143.1	109.6	86.6	70.1	57.9
3-SPAN	LIVE LOAD	200.0	200.0	178.9	136.9	108.2	87.6	72.4
4-SPAN	LIVE LOAD	200.0	200.0	167.0	127.9	101.0	81.8	67.6

NOTES:

1. THE ABOVE LOADS ARE NOT FOR USE WHEN DESIGNING PANELS TO RESIST WIND UPLIFT.
2. Strength calculations based on the 2012 AISI Standard *North American Specification for the Design of Cold-Formed Steel Structural Members*.
3. Allowable loads are applicable for uniform loading and spans without overhangs.
4. LIVE load capacities are for those loads that push the panel against its supports. The applicable limit states are flexure, shear, combined shear and flexure, web crippling at end and interior supports, and a deflection limit of L/180 under strength-level loads.
5. Panel pullover and screw pullout capacity must be checked separately using the screws employed for each particular application when utilizing this load chart.
6. The use of any field seaming equipment or accessories including but not limited to clips, fasteners, and support plates (eave, backup, rake, etc.) other than that provided by the manufacturer may damage panels, void all warranties and will void all engineering data.
7. This material is subject to change without notice. Please contact MBCI for the most current data.

The engineering data contained herein is for the expressed use of customers and design professionals. Along with this data, it is recommended that the design professional have a copy of the most current version of the *North American Specification for the Design of Cold-Formed Steel Structural Members* published by the American Iron and Steel Institute to facilitate design. This Specification contains the design criteria for cold-formed steel components. Along with the Specification, the designer should reference the most current building code applicable to the project jobsite in order to determine environmental loads. If further information or guidance regarding cold-formed design practices is desired, please contact the manufacturer.

SPECIFICATIONS

SECTION 07 41 13 Metal Roofing

PART 1 - GENERAL

1.1 SECTION INCLUDES

- A. Snap joint-seamed, standing seam metal roof panels, with related metal trim and accessories.

1.2 RELATED REQUIREMENTS

Specifier: If retaining this optional article, edit list below to correspond to Project.

- A. Division 01 Section "Sustainable Design Requirements" for related LEED general requirements.
- B. Division 05 Section "Structural Steel Framing" for structural steel framing supporting metal panels.
- C. Division 05 Section "Steel Decking" for continuous metal decking supporting metal panels.
- D. Division 05 Section "Cold-Formed Metal Framing" for cold-formed metal framing supporting metal panels.
- E. Division 05 Section "Cold-Formed Metal Trusses" for cold-formed metal trusses supporting metal panels.
- F. Division 06 Section "Sheathing" for sheathing substrate for metal roof panels.
- G. Division 07 Section ["Thermal Insulation"] ["Roof Insulation"] for thermal insulation installed under metal panels.
- H. Division 07 Section "Air Barriers" for air barriers within roof assembly and adjacent to roof assembly.
- I. Division 07 Section "Metal Wall Panels" for factory-formed metal wall [and soffit] panels.
- J. Division 07 Section "Sheet Metal Flashing and Trim" for formed sheet metal copings, flashings, reglets, and roof drainage items in addition to items specified in this Section.
- K. Division 07 Section "Manufactured Roof Specialties" for manufactured copings, reglets, and roof drainage items in addition to items specified in this Section.
- L. Division 07 Section "Joint Sealants" for field-applied joint sealants.
- M. Division 13 Section "Metal Building Systems" for steel framing supporting metal panels.

1.3 REFERENCES

Specifier: If retaining this optional article, edit list below to correspond to Project.

- A. American Architectural Manufacturer's Association (AAMA): www.aamanet.org:
 1. AAMA 621 - Voluntary Specifications for High Performance Organic Coatings on Coil Coated Architectural Hot Dipped Galvanized (HDG) & Zinc-Aluminum Coated Steel Substrates.
 2. AAMA 809.2 - Voluntary Specification Non-Drying Sealants.

- B. American Society of Civil Engineers (ASCE): www.asce.org/codes-standards:

1. ASCE 7 - Minimum Design Loads for Buildings and Other Structures.

- C. ASTM International (ASTM): www.astm.org:

1. ASTM A 653 - Specification for Steel Sheet, Zinc-Coated (Galvanized) or Zinc-Iron Alloy-Coated (Galvannealed) by the Hot-Dip Process.
2. ASTM A 755 - Specification for Steel Sheet, Metallic Coated by the Hot-Dip Process and Preprimed by the Coil-Coating Process for Exterior Exposed Building Products.
3. ASTM A 792/A 792M - Standard Specification for Steel Sheet, 55 % Aluminum-Zinc Alloy-Coated by the Hot-Dip Process.
4. ASTM A 980 - Standard Specification for Steel, Sheet, Carbon, Ultra High Strength Cold Rolled.
5. ASTM C 645 - Specification for Nonstructural Steel Framing Members.
6. ASTM C 920 - Specification for Elastomeric Joint Sealants.
7. ASTM D 226 - Standard Specification for Asphalt-Saturated Organic Felt Used in Roofing and Waterproofing.
8. ASTM D 2244 - Test Method for Calculation of Color Differences from Instrumentally Measured Color Coordinates.
9. ASTM D 4214 - Test Methods for Evaluating Degree of Chalking of Exterior Paint Films.
10. ASTM E 1592 - Standard Test Method for Structural Performance of Sheet Metal Roof and Siding Systems by Uniform Static Air Pressure Difference.
11. ASTM E 1980 - Practice for Calculating Solar Reflectance Index of Horizontal and Low-Sloped Opaque Surfaces.

- D. Cool Roof Rating Council (CRRC): www.coolroofs.org/productratingprogram.html:

1. CRRC-1-2008 - CRRC Product Rating Program.

- E. International Accreditation Service (IAS):

1. IAS AC 472 - Accreditation Criteria for Inspection Programs for Manufacturers of Metal Building Systems, Part B.

- F. Underwriters Laboratories, Inc. (UL): www.ul.com:

1. UL 580 - Tests for Uplift Resistance of Roof Assemblies

- G. US Environmental Protection Agency:

www.energystar.gov/index.cfm:

1. Energy Star Reflective Roof Products.

- H. US Green Building Council (USGBC): www.usgbc.org:

1. LEED - Leadership in Energy and Environmental Design (LEED) Green Building Rating Systems.

SPECIFICATIONS

1.4 ADMINISTRATIVE REQUIREMENTS

- A. Preinstallation Meeting: Prior to erection of framing, conduct preinstallation meeting at site attended by Owner, Architect, manufacturer's technical representative, inspection agency and related trade contractors.
1. Coordinate building framing in relation to metal panel system.
 2. Coordinate openings and penetrations of metal panel system.
 3. Coordinate work of Division 07 Sections "Roof Specialties" and "Roof Accessories" and openings and penetrations and manufacturer's accessories with installation of metal panels.

1.5 QUALITY ASSURANCE

- A. Manufacturer/Source: Provide metal roof panel assembly and accessories from a single manufacturer providing fixed-base roll forming, and accredited under IAS AC 472 Part B.
- B. Manufacturer Qualifications: Approved manufacturer listed in this Section with minimum five years experience in manufacture of similar products in successful use in similar applications.

Specifier: Retain paragraph below if Owner allows substitutions but requires strict control over qualifying of substituted manufacturers.

1. Approval of Comparable Products: Submit the following in accordance with project substitution requirements, within time allowed for substitution review:
 - a. Product data, including certified independent test data indicating compliance with requirements.
 - b. Samples of each component.
 - c. Sample submittal from similar project.
 - d. Project references: Minimum of five installations not less than five years old, with Owner and Architect contact information.
 - e. Sample warranty.
 - f. IAS AC 472 certificate.
2. Substitutions following award of contract are not allowed except as stipulated in Division 01 General Requirements.
3. Approved manufacturers must meet separate requirements of Submittals Article.

Specifier: Review of manufacturers' qualifying of installers is recommended for larger projects. MBCI requires Installer and supervisor certification when project requirements include extended warranty.

- C. Installer Qualifications: Experienced Installer [certified by metal panel manufacturer] with minimum of five years experience with successfully completed projects of a similar nature and scope.

1. Installer's Field Supervisor: Experienced mechanic [certified by metal panel manufacturer] supervising work on site whenever work is underway.

Specifier: Retain paragraph below and edit as appropriate for Federal projects and for public works projects utilizing Federal funds; consult with project Contracting Officer. Coordinate with Submittals Article.

- D. Buy American Compliance: Materials provided under work of this Section shall comply with the following requirements:
1. Buy American Act of 1933 BAA-41 U.S.C §§ 10a – 10d.
 2. Buy American provisions of Section 1605 of the American Recovery and Reinvestment Act of 2009 (ARRA).

1.6 ACTION SUBMITTALS

- A. Product Data: Manufacturer's data sheets for specified products.

Specifier: Retain and edit below to comply with Project requirements for LEED or other sustainable design requirements.

- B. LEED Submittals:
1. Credit SS 7.2 Heat Island Effect - Roof: Product data indicating compliance with solar reflectance index requirement.
 2. Credit MR 4 Recycled Content: Product data indicating the following:
 - a. Material costs for each product having recycled content.
 - b. Percentages by weight of post-consumer and pre-consumer recycled content for each item.
 - c. Total weight of products provided.
- C. Shop Drawings: Show layouts of metal panels. Include details of each condition of installation, panel profiles, and attachment to building. Provide details at a minimum scale 1-1/2-inch per foot showing edge conditions, joints, fastener and sealant placement, flashings, openings, penetrations, roof accessories, lightning arresting equipment, and special details. Make distinctions between factory and field assembled work.
1. Indicate points of supporting structure that must coordinate with metal panel system installation.
 2. Include data indicating compliance with performance requirements.
 3. Include structural data indicating compliance with requirements of authorities having jurisdiction.
- D. Samples for Initial Selection: For each exposed product specified including sealants. Provide representative color charts of manufacturer's full range of colors.
- E. Samples for Verification: Provide 12-inch- (305 mm-) long section of each metal panel profile. Provide color chip verifying color selection.

SPECIFICATIONS

1.7 INFORMATIONAL SUBMITTALS

- A. Product Test Reports: Indicating compliance of products with requirements, witnessed by a professional engineer.
- B. Qualification Information: For Installer firm and Installer's field supervisor.
- C. IAS Accreditation Certificate: Indicating that manufacturer is accredited under provisions of IAS AC 472.

Specifier: Retain one or more of three paragraphs below when required for project.

- D. Buy American Certification: Manufacturers' letters of compliance acceptable to authorities having jurisdiction, indicating that products comply with requirements.

Specifier: FSBC certification below is available for 12 and 16 inch wide panels.

- E. Florida State Building Code Certificate.
- F. Manufacturer's Warranty: Sample copy of manufacturer's standard warranty.

1.8 CLOSEOUT SUBMITTALS

- A. Maintenance data.
- B. Manufacturer's Warranty: Executed copy of manufacturer's standard warranty.

1.9 DELIVERY, STORAGE, AND HANDLING

- A. Protect products of metal panel system during shipping, handling, and storage to prevent staining, denting, deterioration of components or other damage. Protect panels and trim bundles during shipping.
 - 1. Deliver, unload, store, and erect metal panel system and accessory items without misshaping panels or exposing panels to surface damage from weather or construction operations.
 - 2. Store in accordance with Manufacturer's written instructions. Provide wood collars for stacking and handling in the field.

1.10 COORDINATION

- A. Coordinate sizes, profiles, and locations of roof curbs and other roof-mounted equipment and roof penetrations, based upon sizes of actual selected equipment.

1.11 WARRANTY

Specifier: Warranty terms below are available from MBCI. Verify that other allowable manufacturers furnish warranty meeting requirements.

- A. Special Manufacturer's Warranty: On manufacturer's standard form, in which manufacturer agrees to repair or replace metal panel assemblies that fail in materials and workmanship within one year from date of Substantial Completion.

Specifier: MBCI's optional single source weathertightness warranties below are available for projects installed by an MBCI-certified installer under inspection by an MBCI field technical representative. MBCI representative can provide warranty cost estimate for desired combination of cost limitation and period of warranty desired by owner.

- B. Special Weathertightness Warranty: On manufacturer's standard form, in which manufacturer agrees to repair or replace metal panel assemblies that fail to remain weathertight, including leaks, [without monetary limitation] [up to cost limitation of seven dollars (\$7.00) per square foot of covered area] [up to cost limitation of fourteen dollars (\$14.00) per square foot of covered area] within [5] [10] [15] [20] years from date of Substantial Completion.
- C. Special Panel Finish Warranty: On Manufacturer's standard form, in which Manufacturer agrees to repair or replace metal panels that evidence deterioration of factory-applied finish within [25] years from date of Substantial Completion, including:
 - 1. Fluoropolymer Two- Coat System:

Specifier: Confirm warranted performance values below for custom colors. Second options in subparagraphs below are for MBCI Brite-Red.

- a. Color fading in excess of [5] [10] Hunter units per ASTM D 2244.
- b. Chalking in excess of No. [8] [6] rating per ASTM D 4214.
- c. Failure of adhesion, peeling, checking, or cracking.

- 2. Modified Silicone-Polyester Two-Coat System:

Specifier: Confirm warranted performance values below for custom colors. Second options in subparagraphs below are for MBCI Brite-Red. MBCI Polar White Polyester does not carry a warranty against chalking.

- a. Color fading in excess of [5] [7] Hunter units per ASTM D 2244, for vertical applications.
- b. Color fading in excess of [7] [10] Hunter units per ASTM D 2244, for non-vertical applications.
- c. Chalking in excess of No. [8] [7] rating per ASTM D 4214, for vertical applications.
- d. Chalking in excess of No. [6] [5] rating per ASTM D 4214, for non-vertical applications.
- e. Failure of adhesion, peeling, checking, or cracking.

PART 2 - PRODUCTS

2.1 MANUFACTURER

Specifier: Retain basis of design manufacturer and products listed in this Article where allowed. If inserting comparable manufacturers, carefully review products and engineering capabilities in relation to requirements of this Section, to ensure that other approved manufacturers offer products meeting MBCI's standards.

SPECIFICATIONS

A. Basis of Design Manufacturer: MBCI Metal Roof and Wall Systems, Division of NCI Group, Inc.; Houston TX. Tel: (877) 713-6224; Email: info@mbc.com; Web: mbc.com.

1. Provide basis of design product[, or comparable product approved by Architect prior to bid].

2.2 PERFORMANCE REQUIREMENTS

A. General: Provide metal roof panel system meeting performance requirements as determined by application of specified tests by a qualified testing facility on manufacturer's standard assemblies.

Specifier: Recycled Content paragraph below describes calculation utilized for LEED-NC Credit MR 4. Modify as required to meet project recycled content requirements, or delete if recycled content requirements are stipulated solely in Division 01 Section "Sustainable Design Requirements."

B. Recycled Content: For Steel Products: Postconsumer recycled content plus one-half of preconsumer recycled content not less than [25] percent.

Specifier: Retain one or more radiative property performance subparagraphs below based on project requirements. Retain Solar Reflectance Index for LEED projects. Retain Energy Star reference for projects seeking Energy Star rating; products must be listed on EPA Energy Star website. Retain CRRC compliance for projects required to comply with CEC requirements. Verify values with manufacturer for selected panel finishes. Confirm that Energy Code requirements are also met by below.

C. Radiative Property Performance:

1. Solar Reflectance Index: Minimum 78 for roof slopes of 2:12 or less and 29 for roof slopes greater than 2:12 under medium wind conditions, per ASTM E 1980.
2. Energy Star Qualified: Listed on USDoE ENERGY STAR Roof Products Qualified Product List.
3. Energy Performance: Listed in CRRC Rated Product Directory, with minimum properties as required by applicable Energy efficiency or High-Performance Green Building standard.

D. Structural Performance: Provide metal panel assemblies capable of withstanding the effects of indicated loads and stresses within limits and under conditions indicated:

Specifier: Consult structural engineer and edit below as required by local codes. Insert structural data below if not indicated on drawings. Select applicable deflection limit.

1. Wind Loads: Determine loads based on uniform pressure, importance factor, exposure category, and basic wind speed indicated on drawings.
 - a. Wind Uplift Testing: Certify capacity of metal panels by actual testing of proposed assembly per ASTM E 1592.
2. Snow Loads: [___] lbf/sq. ft. (___ Pa)] [As indicated].

3. Deflection Limits: Withstand inward and outward wind-load design pressures in accordance with applicable building code with maximum deflection of [1/120] [1/180] [1/240] of the span with no evidence of failure.

4. Seismic Performance: Comply with ASCE 7, Section 9, "Earthquake Loads."

E. Wind Uplift Resistance: Comply with UL 580 for wind-uplift class [UL-30] [UL-60] [UL-90].

F. Florida State Building Code Compliance: Comply with requirements of Florida State Building Code. www.floridabuilding.org/pr/pr_app_srch.aspx

G. Thermal Movements: Allow for thermal movements from variations in both ambient and internal temperatures. Accommodate movement of support structure caused by thermal expansion and contraction. Allow for deflection and design for thermal stresses caused by temperature differences from one side of the panel to the other.

Specifier: Retain underlayment materials required for project.

H. Self-Adhering, High-Temperature Underlayment: Cold-applied sheet underlayment minimum 30 mils (0.76 mm) thick, consisting of slip-resistant, polyethylene-film top surface laminated to a layer of butyl or SBS-modified asphalt adhesive, with release-paper backing. Provide primer when recommended by underlayment manufacturer for substrate.

I. Felt Underlayment: Laminated polypropylene and polyethylene sheet, tear-resistant, UV resistant, manufactured with textured surface for slip resistance, meeting performance requirements of ASTM D 226.

2.3 METAL ROOF PANELS

A. Mechanically-seamed, Concealed Fastener, Metal Roof Panels: Structural metal roof panel consisting of formed metal sheet with vertical ribs at panel edges, installed by lapping and mechanically interlocking edges of adjacent panels, and attaching panels to supports using concealed clips and fasteners in a weathertight installation.

1. Basis of Design: **MBCI, LokSeam**, mbci.com/lokseam.html.

Specifier: Material description below corresponds to BIEC International, Inc. <http://galvalume.com/> Galvalume substrate, available Prepainted from MBCI. Second paragraph below describes Galvalume Plus with clear acrylic coating for use as exposed metallic finish.

2. Aluminum-Zinc Alloy-Coated Steel Sheet: ASTM A 792/A 792M, structural quality, Grade 50, Coating Class AZ50 (Grade 340, Coating Class AZM150), prepainted by the coil-coating process per ASTM A 755/A 755M.
3. Aluminum-Zinc Alloy-Coated Steel Sheet: ASTM A 792/A 792M, structural quality, Grade 50, Coating Class AZ55 (Grade 340, Coating Class AZM165) unpainted Galvalume Plus coating.

Specifier: Prior to selecting metal thickness and panel

SPECIFICATIONS

thickness below, consult manufacturer's span tables and review selection against panel thickness requirements and span condition. Select appropriate panel configuration to meet requirements of design wind pressure. Important: Consult this document when specifying gauge with the intent that it meet a prescriptive decimal thickness requirement in addition to strength performance requirements. (Click Here to View)

- a. Nominal Coated Thickness: [26 gage] [24 gage] [22 gage].
 - b. Panel Surface: [Smooth with striations in pan] [Stucco embossed with striations in pan].
 - c. Exterior Finish: [Modified silicone-polyester two-coat system] [Fluoropolymer two-coat system] [Fluoropolymer two-coat metallic color system] [Exposed Galvalume Plus coating].
 - d. Color: [As indicated] [As selected by Architect from manufacturer's standard colors] [Match Architect's custom color].
4. Panel Width: [12 inches (305 mm)] [16 inches (406 mm)] [18 inches (457 mm)].
 5. Panel Seam Height: 1.75 inch (44.4 mm).
 6. Joint Type: Snap joint-seamed.

Specifier: Add underlayment materials if required for project. MBCI LokSeam is a watertight tested panel that does not rely upon underlayment materials for waterproofing. Retain slip sheet when recommended by manufacturer for separating metal panels from underlayment or substrate materials.

2.4 METAL ROOF PANEL ACCESSORIES

- A. General: Provide complete metal roof panel assembly incorporating trim, copings, fasciae, gutters and downspouts, and miscellaneous flashings, in [manufacturer's standard profiles] [profiles as indicated]. Provide required fasteners, closure strips, thermal spacers, splice plates, support plates, and sealants as indicated in manufacturer's written instructions.
- B. Flashing and Trim: Match material, thickness, and finish of metal panel face sheet.
- C. Panel Clips: ASTM C 645, with ASTM A 653/A 653M, G90 (Z180) hot-dip galvanized zinc coating, configured for concealment in panel joints, and identical to clips utilized in tests demonstrating compliance with performance requirements.
- D. Panel Fasteners: Self-tapping screws and other acceptable corrosion-resistant fasteners recommended by roof panel manufacturer. Where exposed fasteners cannot be avoided, supply fasteners with EPDM or neoprene gaskets, with heads matching color of metal panels by means of factory-applied coating.
- E. Joint Sealers: Manufacturer's standard or recommended liquid and preformed sealers and tapes, and as follows:
 1. Factory-Applied Seam Sealant: Manufacturer's standard hot-melt type.

2. Tape Sealers: Manufacturer's standard non-curing butyl tape, AAMA 809.2.
3. Concealed Joint Sealant: Non-curing butyl, AAMA 809.2.

Specifier: Retain one or more of the following four optional paragraphs as required by Project.

- F. Steel Sheet Miscellaneous Framing Components: ASTM C 645, with ASTM A 653/A 653M, G60 (Z180) hot-dip galvanized zinc coating.
- G. Roof Accessories: Approved by metal roof panel manufacturer. Refer to Section 07 72 00 "Roof Accessories" for requirements for curbs, equipment supports, roof hatches, heat and smoke vents, ventilators, and preformed flashing sleeves.
- H. Snow Guards: Approved by metal roof panel manufacturer. Refer to Section 07 72 53 "Snow Guards" for requirements for snow guards attached to metal roof panels.

2.5 FABRICATION

- A. General: Provide factory fabricated and finished metal panels and accessories meeting performance requirements, indicated profiles, and structural requirements.
- B. Fabricate metal panel joints configured to accept factory-applied sealant providing weathertight seal and preventing metal-to-metal contact and minimizing noise resulting from thermal movement.
- C. Form panels in continuous lengths for full length of detailed runs, except where otherwise indicated on approved shop drawings.
- D. Sheet Metal Flashing and Trim: Fabricate flashing and trim to comply with manufacturer's written instructions, approved shop drawings, and project drawings. Form from materials matching metal panel substrate and finish.

2.6 FINISHES

- A. Finishes, General: Prepare, pretreat, and apply coating to exposed metal surfaces to comply with coating and resin manufacturers' written instructions.

Specifier: Retain one or more of the following three finish paragraphs as applicable to the project. Coordinate with Warranty article in Part 1.

- B. Modified Silicone-Polyester Two-Coat System: 0.20 – 0.25 mil primer with 0.7 – 0.8 mil color coat[meeting solar reflectance index requirements].
 1. Basis of Design: MBCI, Signature 200.

Specifier: MBCI's fluoropolymer coatings are based on Arkema, Inc. Kynar 500 and Solvay Solexis Hylar 500 PVF2 resins. Retain optional requirement for solar reflectance index when required for project; coordinate with selected color.

- A. Fluoropolymer Two-Coat System: 0.2 – 0.3 mil primer with 0.7 - 0.8 mil 70 percent PVDF fluoropolymer color coat, AAMA 621[meeting solar reflectance index requirements].

SPECIFICATIONS

1. Basis of Design: MBCI, Signature 300.
- B. Fluoropolymer Two-Coat Metallic System: 0.2 – 0.3 mil primer with 0.7 - 0.8 mil 70 percent PVDF metallic fluoropolymer color coat, AAMA 621[, meeting solar reflectance index requirements].
 1. Basis of Design: MBCI, Signature 300 Metallic.
- C. Interior Finish: 0.5 mil total dry film thickness consisting of primer coat and wash coat of manufacturer's standard light-colored acrylic or polyester backer finish.

- d. Hips and ridges for a distance on each side of 18 inches (460 mm).
- e. Roof-to-wall intersections for a distance from wall of 18 inches (460 mm).
- f. Around roof penetrating elements for a distance from element of 18 inches (460 mm).

- C. Felt Underlayment: Apply at locations indicated below, in accordance with underlayment manufacturer's written instructions.

Specifier: Retain one of two subparagraphs below or delete both if indicated on Drawings.

1. Apply over the entire roof surface.
2. Apply on area of roof not covered by self-adhering sheet underlayment. Lap over edges of self-adhering sheet underlayment not less than 6 inches (150 mm).

Specifier: Retain "Slip Sheet" Paragraph below if required.

- D. Flashings: Provide flashings as required to complete metal roof panel system. Install in accordance with Section 07 62 00 "Sheet Metal Flashing and Trim" and approved shop drawings.

PART 3 - EXECUTION

3.1 EXAMINATION

- A. Examine metal panel system substrate and supports with Installer present. Inspect for erection tolerances and other conditions that would adversely affect installation of metal panel installation.
 1. Inspect metal panel support substrate to determine if support components are installed as indicated on approved shop drawings. Confirm presence of acceptable supports at recommended spacing to match installation requirements of metal panels.
 2. Panel Support Tolerances: Confirm that panel supports are within tolerances acceptable to metal panel system manufacturer but not greater than the following:
 - a. 1/4 inch (6 mm) in 20 foot (6.1 m) in any direction.
 - b. 3/8 inch (9 mm) over any single roof plane.
- B. Correct out-of-tolerance work and other deficient conditions prior to proceeding with insulated metal roof panel system installation.

3.2 PREPARATION

- A. Miscellaneous Supports: Install subframing, girts, furring, and other miscellaneous panel support members according to ASTM C 754 and manufacturer's written instructions.

Specifier: Retain paragraph(s) below for metal roof panels applied over solid roof sheathing. Retain "Self-Adhering Sheet Underlayment" or "Felt Underlayment" Paragraph below or retain both if required.

- B. Self-Adhering Sheet Underlayment: Apply in accordance with underlayment manufacturer's written instructions; apply primer if required. Apply at locations indicated below. Roll laps with roller. Retain one of two subparagraphs below.
 1. Apply over the entire roof surface.
 2. Apply over the roof area indicated below:
 - a. Roof perimeter for a distance up from eaves of 24 inches (610 mm) beyond interior wall line.
 - b. Valleys, from lowest point to highest point, for a distance on each side of 18 inches (460 mm).
 - c. Rake edges for a distance of 18 inches (460 mm).

3.3 METAL PANEL INSTALLATION

- A. Snap-Joint-Seamed, Standing Seam Metal Roof Panels: Install weathertight metal panel system in accordance with manufacturer's written instructions, approved shop drawings, and project drawings. Install metal roof panels in orientation, sizes, and locations indicated, free of waves, warps, buckles, fastening stresses, and distortions. Anchor panels and other components securely in place. Provide for thermal and structural movement.
- B. Attach panels to supports using clips, screws, fasteners, and sealants recommended by manufacturer and indicated on approved shop drawings.
 1. Fasten metal panels to supports with concealed clips at each location indicated on approved shop drawings, with spacing and fasteners recommended by manufacturer.
 2. Snap Joint: Nest standing seams and fasten together by interlocking and completely engaging factory-applied sealant.
 3. Provide weatherproof jacks for pipe and conduit penetrating metal panels of types recommended by manufacturer.
 4. Dissimilar Materials: Where elements of metal panel system will come into contact with dissimilar materials, treat faces and edges in contact with dissimilar materials as recommended by manufacturer.

SPECIFICATIONS

3.4 ACCESSORY INSTALLATION

- A. General: Install metal panel trim, flashing, and accessories using recommended fasteners and joint sealers, with positive anchorage to building, and with weather tight mounting. Provide for thermal expansion. Coordinate installation with flashings and other components.
 - 1. Install components required for a complete metal panel assembly, including trim, copings, flashings, sealants, closure strips, and similar items.
 - 2. Comply with details of assemblies utilized to establish compliance with performance requirements and manufacturer's written installation instructions.
 - 3. Provide concealed fasteners except where noted on approved shop drawings.
 - 4. Set units true to line and level as indicated. Install work with laps, joints, and seams that will be permanently weather resistant.
- B. Joint Sealers: Install joint sealers where indicated and where required for weathertight performance of metal panel assemblies, in accordance with manufacturer's written instructions.
 - 1. Prepare joints and apply sealants per requirements of Division 07 Section "Joint Sealants."

3.5 FIELD QUALITY CONTROL

Specifier: Retain paragraph below when scope and complexity of metal roof panel installation justifies independent inspection and testing provisions.

- A. Testing Agency: [Owner will engage] [Engage] an independent testing and inspecting agency acceptable to Architect to perform field tests and inspections and to prepare test reports.

3.6 CLEANING AND PROTECTION

- A. Remove temporary protective films immediately in accordance with metal roof panel manufacturer's instructions. Clean finished surfaces as recommended by metal roof panel manufacturer.
- B. Replace damaged panels and accessories that cannot be repaired to the satisfaction of the Architect.

END OF SECTION

GENERAL INFORMATION

PRODUCT CHECKLIST

<p>LokSeam® Panel</p> <p>18" 16" 12"</p> <p><input type="checkbox"/> <input type="checkbox"/> <input type="checkbox"/></p>	<p>Back-Up Plate</p> <ul style="list-style-type: none"> • For use at ridge and endlaps • Prepunched • 16-gauge red oxide <p>HW-7762 18" <input type="checkbox"/> HW-7766 16" <input type="checkbox"/> HW-7764 12" <input type="checkbox"/></p>	<p>Floating Rake Support</p> <ul style="list-style-type: none"> • 20' Length • 14-gauge red oxide • Factory slots <p>HW-4680 <input type="checkbox"/></p>
<p>Clips</p> <p>Standard - HW-6200 <input type="checkbox"/> UL 90 - HW-6400 <input type="checkbox"/></p>	<p>Bearing Plate Standard</p> <ul style="list-style-type: none"> • 16-gauge red oxide • For use with rigid-board insulation <p>HW-7500 <input type="checkbox"/></p>	<p>Support Plates</p> <p>SPECIFY ANGLE Floating Ridge/Hip P-141 <input type="checkbox"/> SPECIFY ANGLE Fixed Ridge P-140 <input type="checkbox"/></p>
<p>Ridge Flash, Floating</p> <p>SPECIFY ANGLE T-5087 <input type="checkbox"/></p>	<p>Ridge Flash for Vent</p> <ul style="list-style-type: none"> • For use with vent material <p>COLOR SPECIFY ANGLE T-5089 <input type="checkbox"/></p>	<p>Ridge Flash for Vent</p> <ul style="list-style-type: none"> • For use with vent material <p>COLOR SPECIFY ANGLE FL-540 <input type="checkbox"/></p>
<p>Ridge/Hip Flash, Fixed</p> <p>COLOR SPECIFY ANGLE T-5075 <input type="checkbox"/></p>	<p>Peak Cap</p> <p>COLOR SPECIFY ANGLE T-5085 <input type="checkbox"/></p>	<p>Box Rake</p> <p>COLOR SPECIFY ANGLE T-5238 <input type="checkbox"/></p>

NOTE: All trim to be 24-gauge material unless noted
SUBJECT TO CHANGE WITHOUT NOTICE

GENERAL INFORMATION

PRODUCT CHECKLIST

<p>Eave Trim</p> <p>T-5141 <input type="checkbox"/></p>	<p>Eave Trim w Drip Edge</p> <p>T-5151 <input type="checkbox"/></p>	<p>Box Gutter</p> <p>T-5261 <input type="checkbox"/></p>
<p>Box Gutter w/Drip Edge</p> <p>T-5271 <input type="checkbox"/></p>	<p>Snow Gutter</p> <p>(Please Inquire)</p>	<p>Gutter End</p> <p>T-5291 <input type="checkbox"/></p> <p>Gutter Strap</p> <p>T-5281 <input type="checkbox"/></p>
<p>Valley Trim - Standard</p> <p>Specify Roof Pitch T-5093 <input type="checkbox"/></p>	<p>Valley Trim - Extended</p> <p>Specify Roof Pitch T-5097 <input type="checkbox"/></p>	<p>Parapet High Side Eave Flash-Fixed</p> <p>T-5211 <input type="checkbox"/> T-5213 <input type="checkbox"/></p>
<p>Parapet High Side Eave Flash-Floating</p> <p>T-5215 <input type="checkbox"/></p>	<p>Parapet Rake Flash</p> <p>T-5217 <input type="checkbox"/></p>	<p>Parapet Rake Cleat</p> <p>T-5219 <input type="checkbox"/></p>

NOTE: All trim to be 24-gauge material unless noted
LS-22 REV 00.05

GENERAL INFORMATION

PRODUCT CHECKLIST

<p>Counterflash</p> <p>T-5225 <input type="checkbox"/></p>	<p>Alternate Counterflash</p> <p>T-5221 <input type="checkbox"/></p>	<p>Offset Cleat</p> <p>T-5131 <input type="checkbox"/></p>
<p>Continuous Cleat</p> <p>T-5121 <input type="checkbox"/></p>	<p>Zee Closure</p> <p>T-5014 <input type="checkbox"/></p>	<p>Perforated Vent Drip</p> <p>FL-254 <input type="checkbox"/></p>
<p>Metal Vent Material</p> <p>HW-525 <input type="checkbox"/></p>	<p>Rib Cover</p> <p>FL-565 <input type="checkbox"/></p>	<p>Panel Hemming Tool</p> <p>HW-602 <input type="checkbox"/></p>
<p>Tape Sealer</p> <ul style="list-style-type: none"> • For use at eave, ridge, and endlaps <p>Tri-Bead</p> <p>HW-504 <input type="checkbox"/></p>	<p>Tape Sealer</p> <ul style="list-style-type: none"> • For use at valleys with through fasteners <p>Triple Bead</p> <p>HW-502 <input type="checkbox"/></p>	<p>Tube Sealant</p> <ul style="list-style-type: none"> • Paintable • Urethane <p>HW-540 — WHITE <input type="checkbox"/> HW-541 — GRAY <input type="checkbox"/> HW-544 — ALMOND <input type="checkbox"/> HW-542 — MED. BRONZE <input type="checkbox"/></p>

GENERAL INFORMATION



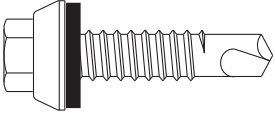
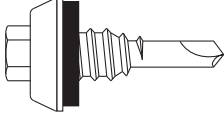
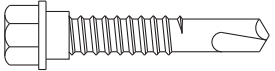
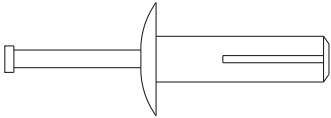
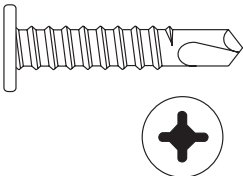
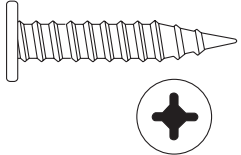

PRODUCT CHECKLIST

<p>Fastener #1E</p> <ul style="list-style-type: none"> • Panel to eave strut • Standard endlap • Panel to valley plate (fixed) • Floating Rake or Parapet Rake  <p>1/4" - 14 x 1 1/4" Long Life Driller 5/16" Hex Washer Head with sealing washer <input type="checkbox"/></p>	<p>Fastener #4</p> <ul style="list-style-type: none"> • zee closure to panel at ridge (without back-up plate)  <p>1/4" - 14 x 7/8" Lap Tek 5/16" Hex Washer Head with 5/8" O.D. washer <input type="checkbox"/></p>
<p>Fastener #5</p> <ul style="list-style-type: none"> • Rake support to purlin  <p>1/4" - 14 x 1 1/4" Shoulder Tek 2 5/16" Hex Washer Head no washer <input type="checkbox"/></p>	<p>Fastener #11</p> <ul style="list-style-type: none"> • Parapet rake flash to masonry parapet wall  <p>1/4" x 1 1/4" Nail Drive Masonry Anchor <input type="checkbox"/></p>
<p>Fastener #12A</p> <ul style="list-style-type: none"> • Clip to purlin • Offset cleat/panel starter to eave strut or valley plate  <p>12-11 x 1" Pancake Head with #3 Drill Point #2 Quadrex Drive <input type="checkbox"/></p>	<p>Fastener #13A</p> <ul style="list-style-type: none"> • Clip to plywood • zee closure to plywood • Offset cleat to plywood  <p>12-11 x 1" Pancake Head Type A #2 Quadrex Drive <input type="checkbox"/></p>

NOTE: All trim to be 24-gauge material unless noted

GENERAL INFORMATION

PRODUCT CHECKLIST

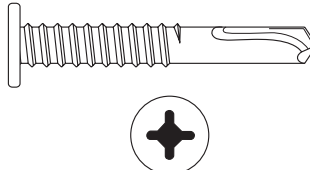
<p>Fastener #14</p> <ul style="list-style-type: none"> • Trim to trim • Trim to panel  <p>1/8" x 0.337" Pop Rivet stainless steel <input type="checkbox"/></p>	<p>Fastener #14A</p> <ul style="list-style-type: none"> • zee Closure to angle at floating hip  <p>1/8" x 0.525" Pop Rivet stainless steel <input type="checkbox"/></p>
<p>Fastener #210</p> <ul style="list-style-type: none"> • For clip attachment in a composite roof assembly • Fastens clip and bearing plate to metal deck in rigid board insulation over metal deck applications • Length to be determined by insulation thickness and metal deck depth  <p>14 x 3" Deck Screw #3 Phillips Truss Head <input type="checkbox"/></p>	<p>Fastener #211</p> <ul style="list-style-type: none"> • For clip attachment in a composite roof assembly • Fastens clip and bearing plate to metal deck in rigid board insulation over metal deck applications • Length to be determined by insulation thickness and metal deck depth  <p>14 x 4" Deck Screw Driller #3 Phillips Truss Head <input type="checkbox"/></p>
<p>Fastener #15D</p> <ul style="list-style-type: none"> • For clip attachment in a composite roof assembly • Fastens clip and bearing plate to metal deck in rigid board insulation over metal deck applications • Length to be determined by insulation thickness and metal deck depth  <p>14 x 6" Deck Screw #3 Phillips Truss Head <input type="checkbox"/></p>	<p>Fastener #16</p> <ul style="list-style-type: none"> • Clip to joist • Offset cleat/panel starter to joist  <p>12 x 24 x 1/4" #2 Quadrex Drive <input type="checkbox"/></p>

NOTE: All trim to be 24-gauge material unless noted
 SUBJECT TO CHANGE WITHOUT NOTICE

GENERAL INFORMATION

ORDERING INFORMATION

When ordering **LokSeam**® panels without technical assistance from MBCI, the following must be provided:

1. Panel Length -The length of each panel should include the proper overhang at the eave, endlap, and peak as required. Refer to specific details in this manual for the proper overhang at these locations. **Add 1½" to the panel length for all panels to be hemmed as shown on page LS-35.**
2. Panel Designations - Each panel must have a designation to be properly manufactured. These designations are: Blank, Peak, Mid and Eave.
3. Panels may be specified as: "Notched" for folding hem at eave. Add 3" to panel length. If factory notching is requested, panels will be notched 1½" at both ends. **Note: Notching is only available for Blank Panels.**

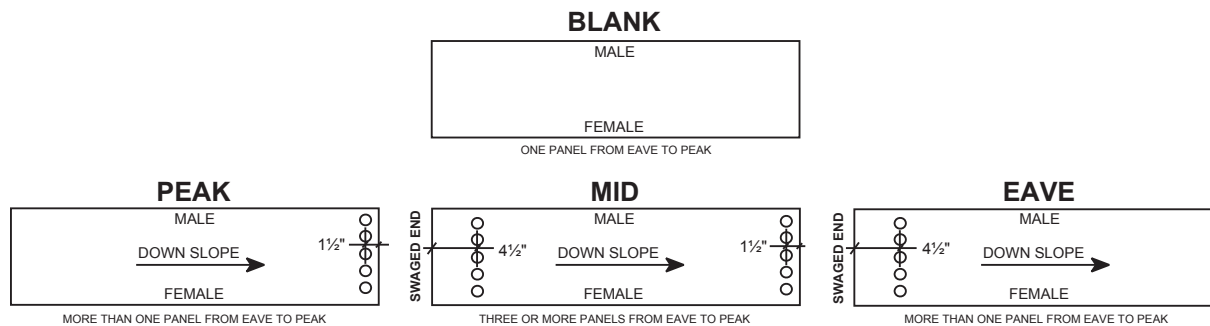

4. 16" wide panels can be swaged but not prepunched.
5. If you are using an endlap with an offset cleat as shown on **pages LS-37 and LS-53**, you must also specify that the panels *not be prepunched*. Panels will still be swaged as normal. If your specific detail is not in this manual or if you have questions concerning panel length, designation, or product application, call your MBCI sales representative.

INSTALLATION GUIDELINES

- I. Pre-Order
 - A. Prior to ordering panels, all dimensions should be confirmed by field measurement.
- II. Job site Storage and Handling
 - A. Check the shipment against the shipping list.
 - B. Damaged material must be noted on Bill of Lading.
 - C. Panel crates should be handled carefully. A spreader bar of appropriate length is recommended for hoisting.
 - D. Check to see that moisture has not formed inside the bundles during shipment. If moisture is present, panels should be uncrated and wiped dry, then restacked and loosely covered so that air can circulate between the panels.
- III. Application Checklist
 - A. Check substructure for proper alignment and uniformity to avoid panel distortion.
 - B. Periodic check of panel alignment is crucial to proper panel alignment.
 - C. If there is a conflict between this manual and the erection drawings, the erection drawings will take precedence.

GENERAL INFORMATION

PREPARATORY REQUIREMENTS

1. A single pitch eave strut must be used with the **LokSeam®** Roof System.
2. Make sure a rake angle or an alternate structural flat surface has been installed on top of the purlins to accept the "Rake Support".
3. The walls do not have to be erected before the roof is installed. However, for the purpose of this manual, we have assumed that the wall panels have been installed.
4. The substructure (eave to ridge) must be on plane tolerance of $\frac{1}{4}$ " in 20' and $\frac{3}{8}$ " in 40'.
5. It is critical that the purlins or bar joists at the ridge and endlaps be located exactly as detailed and that they are straight from rafter to rafter. Any mislocation or bowing of these members can cause the fasteners at the ridge or endlaps to foul as the panels expand and contract.
6. Peak Purlin Spacing -Floating Ridge: 18" (9" from center line of ridge to web of purlin).
-Fixed Ridge: 10" (5" from center line of ridge to web of purlin).
7. MBCI can furnish **LokSeam®** roof panels in 18", 16" and 12" widths. However, for the purpose of this manual, we have assumed that the roof panels will be 18" wide.

CAUTION

Application and design details are for illustration purposes only, and may not be appropriate for all environmental conditions or building designs. Projects should be engineered to conform to applicable building codes, regulations, and accepted industry practices.

CAUTION

Diaphragm capabilities and purlin stability are not provided by MBCI's **LokSeam®** roof system. Therefore, other bracing may be required to conform to A.I.S.C. or A.I.S.I. specifications.

GENERAL INFORMATION

RIGHT WAY

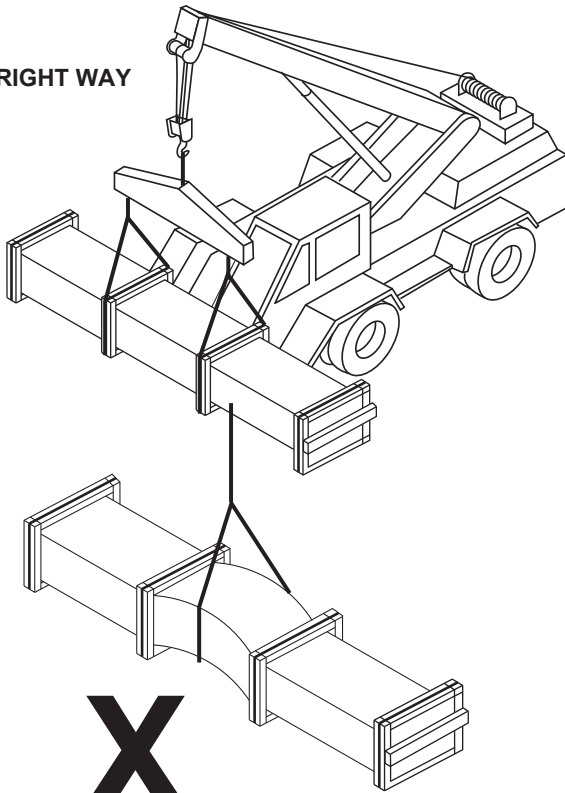

X

WRONG WAY

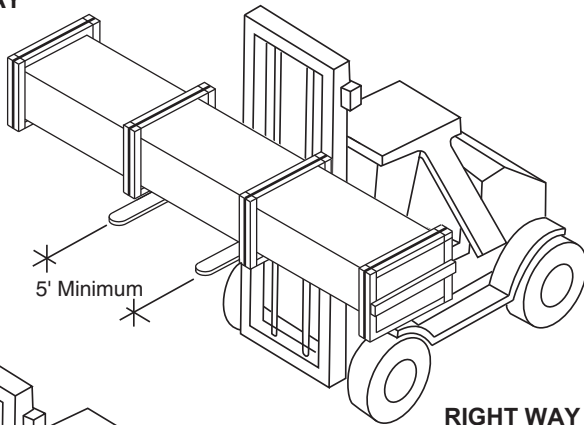

RIGHT WAY

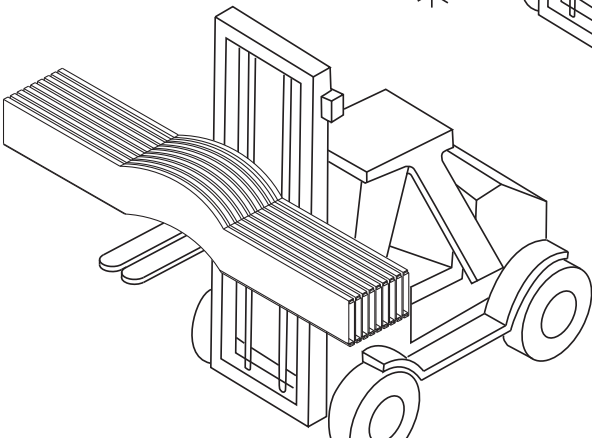

X

WRONG WAY

UNLOADING

Upon receiving material, check shipment against shipping list for shortages and damages. MBCI will not be responsible for shortages or damages unless they are noted on the shipping list.

Each bundle should be lifted at its center of gravity. Where possible, bundles should remain banded until final placement on roof. If bundles must be opened, they should be retied before lifting.

When lifting bundles with a crane, a spreader bar and nylon straps should be used. **NEVER USE WIRE, ROPE OR CHAIN SLINGS, THEY WILL DAMAGE THE PANELS.**

When lifting bundles with a forklift, forks must be a minimum of five feet apart. Do not transport open bundles. Drive slowly when crossing rough terrain to prevent panel buckling.

CAUTION

Improper unloading and handling of bundles and crates may cause bodily injury or material damage. The manufacturer is not responsible for bodily injuries or material damages during unloading and storage.

GENERAL INFORMATION

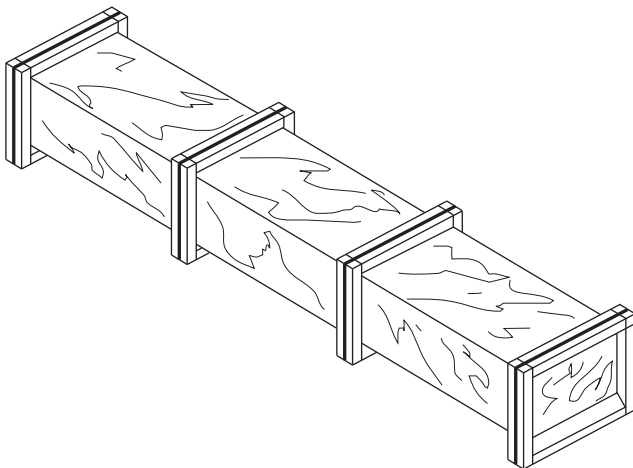
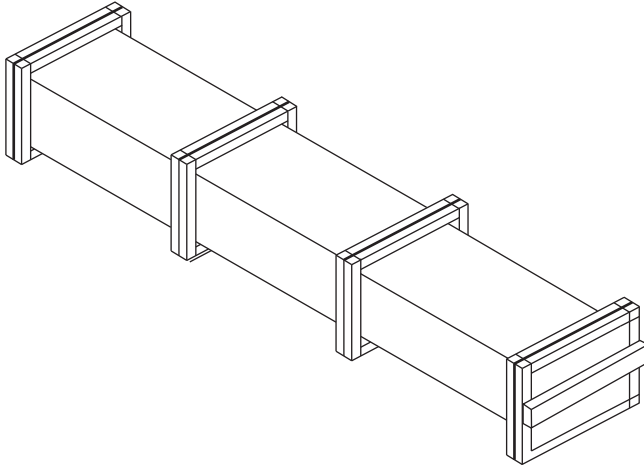

UNLOADING (continued)

BLOCK AND BAND WITH CARDBOARD CARTON

This method of bundling is used for orders that are to be picked up by the customer or shipped by common carrier. 2 x 4's are strapped under the cartons to allow access for straps or a forklift. Bundles less than 25' long may be handled by a forklift. The forklift should have at least 5' between forks. Cartons longer than 25' should be lifted utilizing a spreader bar with nylon straps.

FULL CRATE

This method is used on all overseas shipments or by customer's order. Handling requirements are the same as block and band.

GENERAL INFORMATION

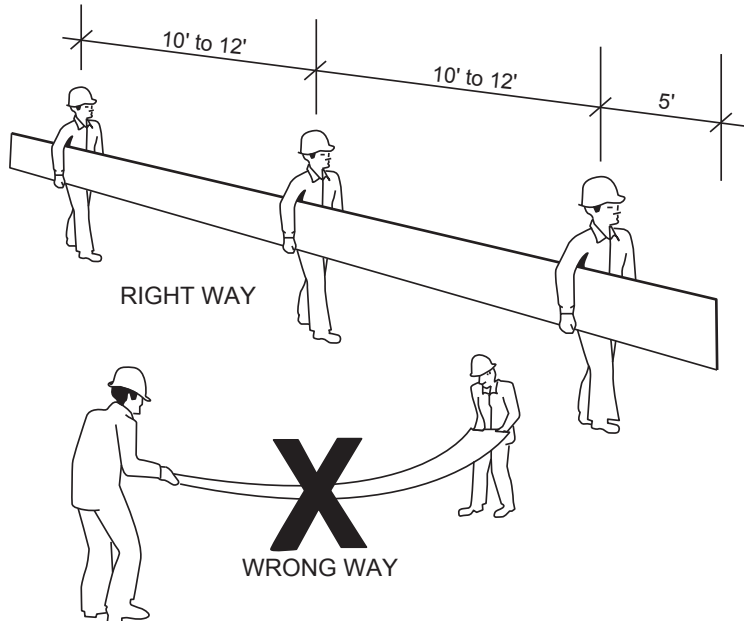

HANDLING/ PANEL STORAGE

Standing on one side of the panel, lift it by the seam. If the panel is over 10' long, lift it with two or more people on one side of the panel to prevent buckling.

Do not pick panels up by the ends.

NOTE

Protective gloves should always be used while handling panels. OSHA safety regulations must be followed at all times.

Store bundled sheets off the ground sufficiently high to allow air circulation beneath bundle and to prevent rising water from entering bundle. Slightly elevate one end of bundle. Prevent rain from entering bundle by covering with tarpaulin, making provision for air circulation between draped edges of tarpaulin and the ground.

PROLONGED STORAGE OF SHEETS IN A BUNDLE IS NOT RECOMMENDED. If conditions do not permit immediate erection, extra care should be taken to protect sheets from white rust or water marks.

Check to see that moisture has not formed inside the bundles during shipment. If moisture is present, panels should be uncrated and wiped dry, then restacked and loosely covered so that air can circulate between the panels.

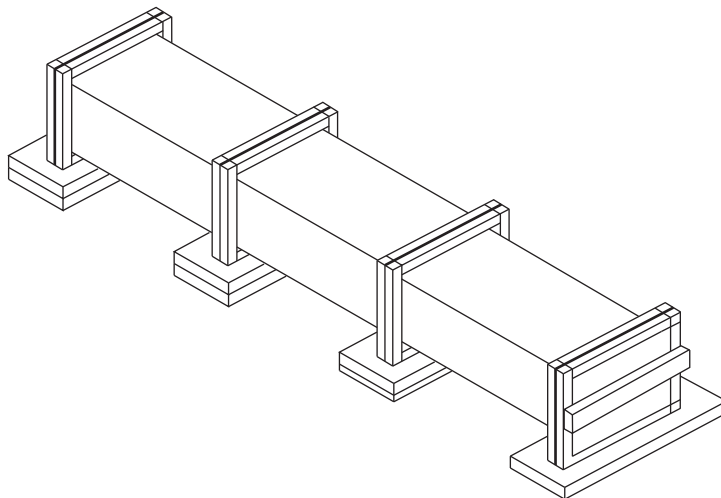

DETAILS

ROOF CURB INSTALLATION INSTRUCTIONS

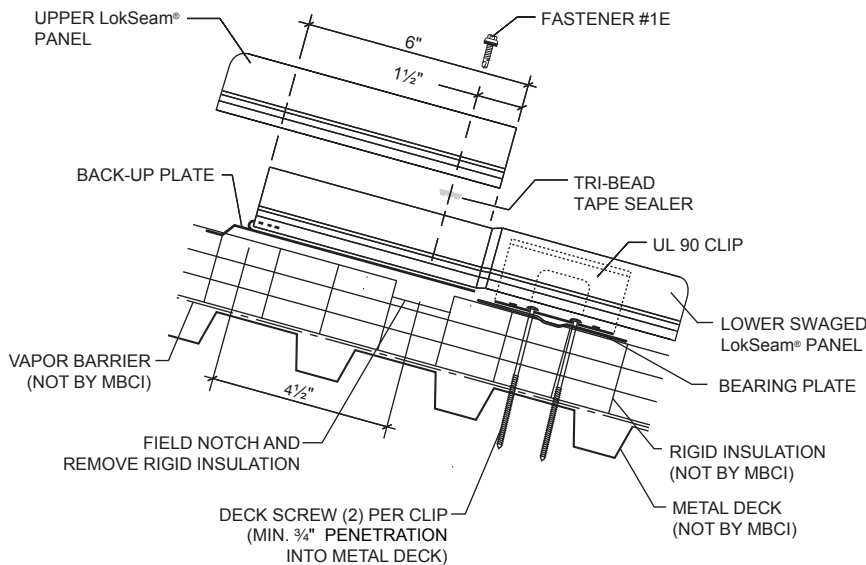

MBCI recommends that only one-piece .080 Aluminum (Min.) roof curbs be used with the LokSeam® roof system. The roof curb will be installed under the roof panels on the upslope end and over the panels at the downslope end. To accomplish this, the roof panels must be overlapped at the upslope and downslope end of the curb. This allows both ends of the curb to shed water and places the heavier gauge metal of the curb under the roof panels for better resistance to foot traffic. The exception is at the downslope end where the curb is on top of the roof panels. Since there are overlaps at this area, back-up plates provide support.

Outside cap cells (for bottom) are used to seal the panel to the roof curb. If the curb must be located in a precise location, order the cap cells loose for field installation.

For the purpose of these instructions, a curb with a factory attached cap cell is illustrated. Panels are assumed to be blank and installed right to left.

CAUTION

It is the user's responsibility to ensure that openings cut into the roof for installation of roof curbs comply with State, Federal and OSHA regulations and laws, including, but not limited to, guarding roof openings with plywood, fixed standard railings, or other acceptable safety controls that prevent fall-through.

DETAILS

ROOF CURB INSTALLATION INSTRUCTIONS (continued)

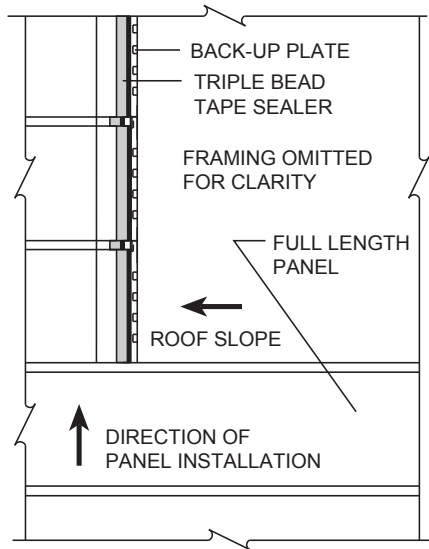

Full length panels may be installed up to the curb location. All panel runs affected by a roof curb must have field endlaps at the upslope and downslope end of the curb. Provision must be made for this condition by ordering two panels 12" longer than the panels immediately adjacent to the curb. The panels do not need to be ordered with pre-punched holes. Install all bottom panels, engaging backup plates and apply triple bead tape sealer to each panel as it is being installed. **It is critical that the tape sealer be installed across the full panel width.** Failure to follow this procedure will cause the curb to leak during rains coupled with high winds.

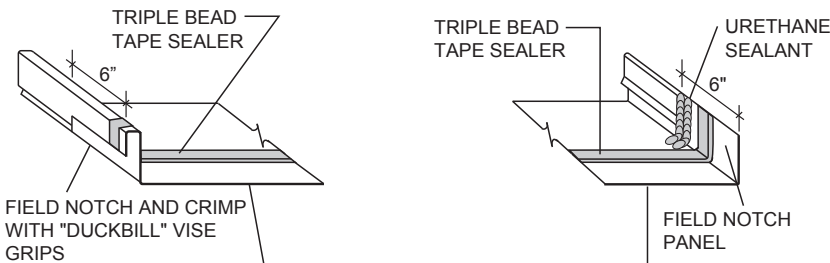

The first downslope panel immediately adjacent to the last full length panel will require field notching of the female leg for a distance of 6". Notch the panel just above the lock in the female leg. The remaining portion of the female leg will need to be crimped with "duckbill" vise grips.

The last downslope panel immediately adjacent to the first full length panel after the curb will require field notching of the male leg for a distance of 6". Notch the panel by removing the male "lock" leg only. Apply two beads of urethane sealant vertically to the downslope end of the notch.

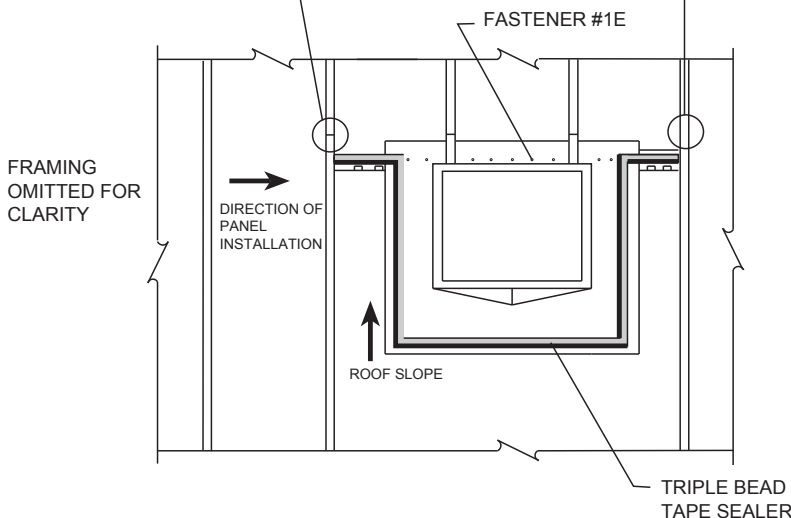

CAUTION

It is the user's responsibility to ensure that openings cut into the roof for installation of roof curbs comply with State, Federal and OSHA regulations and laws, including, but not limited to, guarding roof openings with plywood, fixed standard railings, or other acceptable safety controls that prevent fall-through.

DETAILS

ROOF CURB INSTALLATION INSTRUCTIONS (continued)

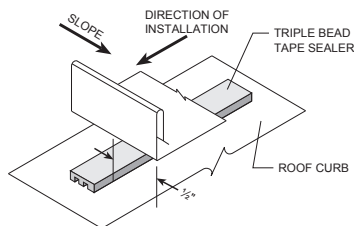
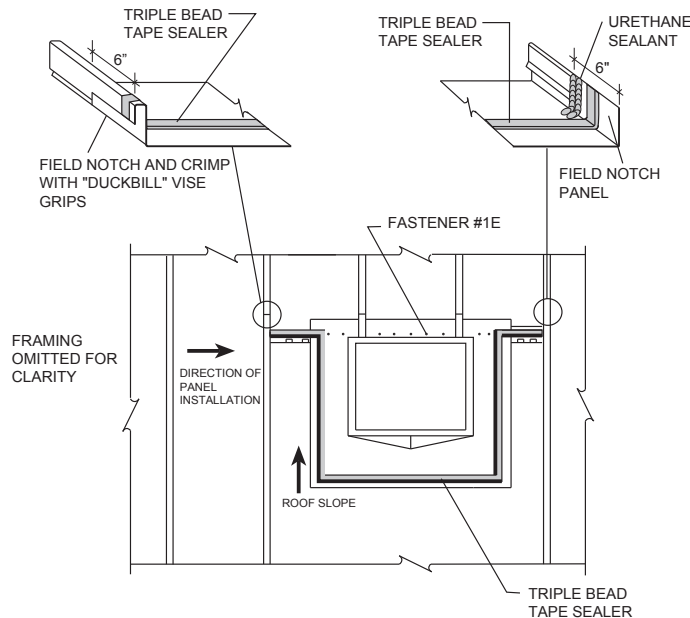

Install curb on top of bottom panels and curb support framing. When using a loose cap cell, the curb flange must be notched out to accept the panel rib. Apply triple bead tape sealer to the sides and upslope end of curb. Fasten the downslope end of curb to the bottom roof panels and back-up plates with Fastener #1E at 3" o.c. Fasteners must go through the tape sealer.

Install the top run of panels cutting the panels at each side of the curb to fit. Apply urethane sealant to seams of all panels on the upslope end of the curb. End of top panels should be a minimum of 12" from the point of the water diverter. The top panel should lap onto the curb 6".

Install cinch straps at sides of curb to form a compression seal (cinch straps not by MBCI) Fasten cinch straps and top panels with Fastener #1E at 3" o.c. Fasteners must go through the triple bead tape sealer.

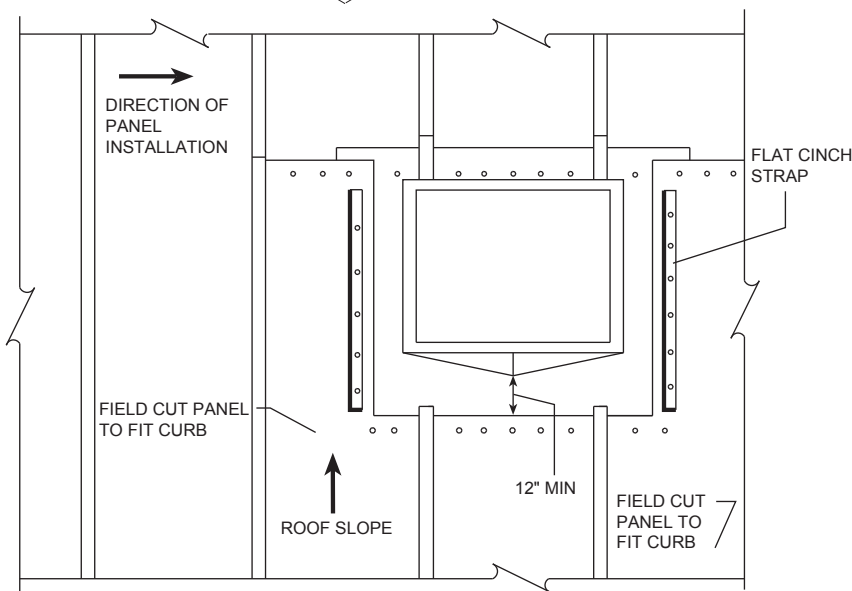

Full length panels may now once again be used.

CAUTION

It is the user's responsibility to ensure that openings cut into the roof for installation of roof curbs comply with State, Federal and OSHA regulations and laws, including, but not limited to, guarding roof openings with plywood, fixed standard railings, or other acceptable safety controls that prevent fall-through.

DETAILS

ROOF CURB INSTALLATION INSTRUCTIONS (continued)

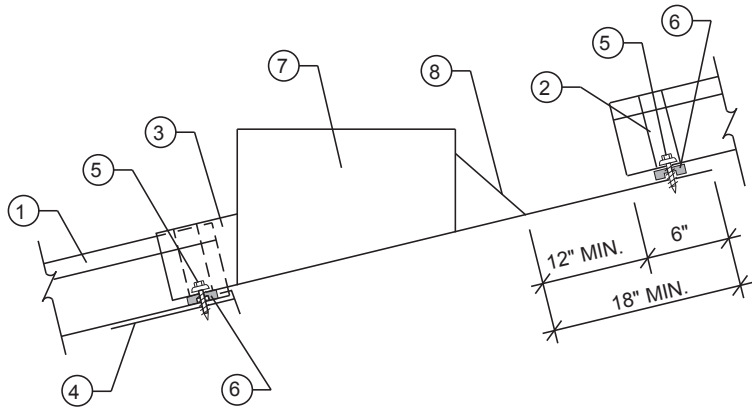

- 1. LokSeam® Panel
- 2. Urethane Sealant
- 3. Outside Cap Cell
- 4. Back-up Plate
- 5. Fastener #1E
- 6. Tri-bead Tape Sealer
- 7. Roof Curb Made From Structural Aluminum (Min. .080 Thickness)
- 8. Water Diverter
- 9. Panel Fins (to be cut from panel length equal to length of curb).

When ordering curbs, specify one-piece curbs as shown on this page.

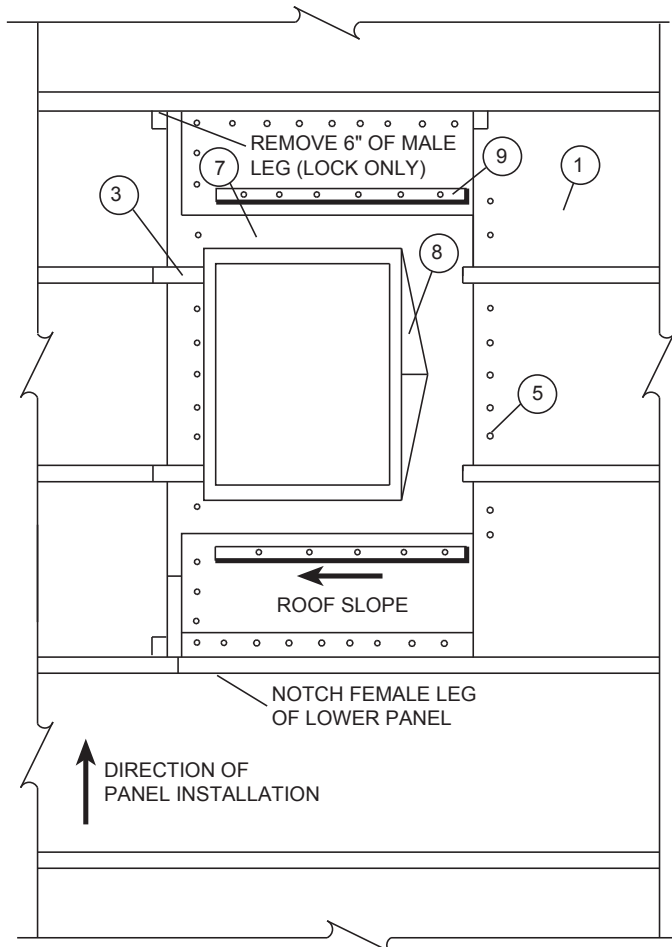

CAUTION

It is the user's responsibility to ensure that openings cut into the roof for installation of roof curbs comply with State, Federal and OSHA regulations and laws, including, but not limited to, guarding roof openings with plywood, fixed standard railings, or other acceptable safety controls that prevent fall-through.

DETAILS

FIELD HEMMING PANEL END

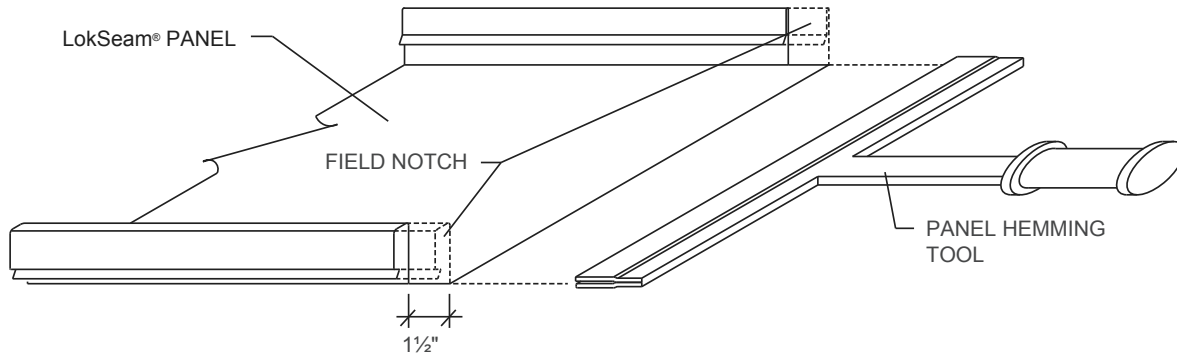

NOTCHING PANEL END

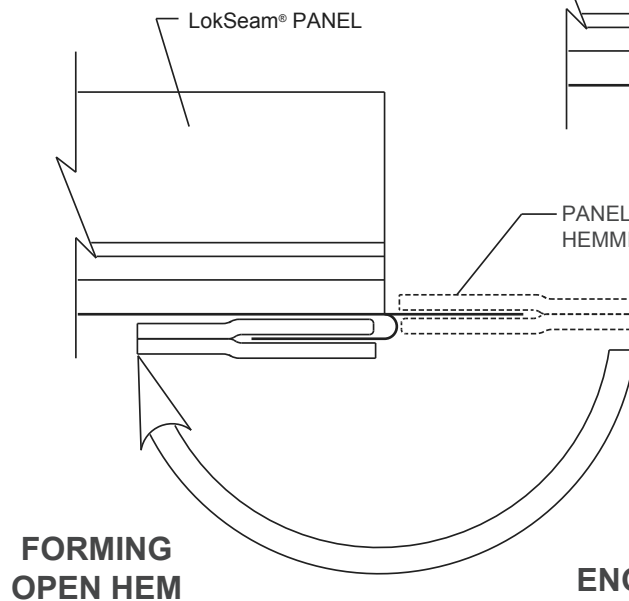
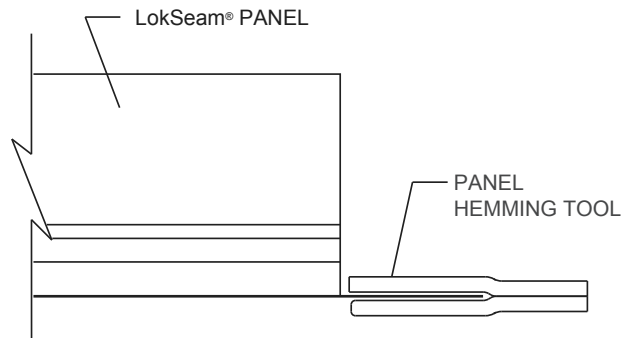

ENGAGING HEMMING TOOL

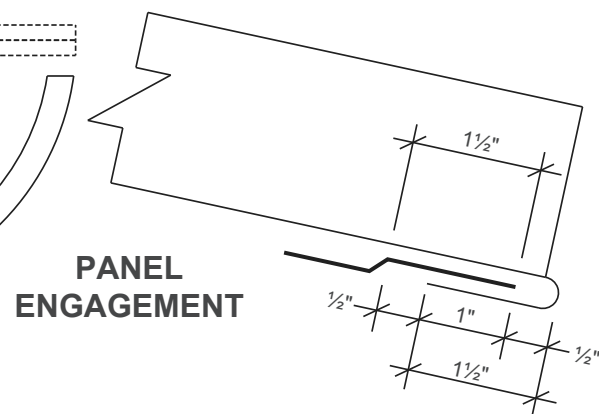

NOTES:

1. Field notch male and female legs of panel 1 1/2". (Factory notching is available, call MBCI)
2. Engage panel hemming tool onto protruding panel.
3. Bend panel down to form an open hem.
4. Hem may be tightened with a pair of vise grip "duck bills."
5. Panel engagement shown above is for panel runs up to 100' long. For panel runs over 100' long, please call MBCI.

DETAILS

PANEL

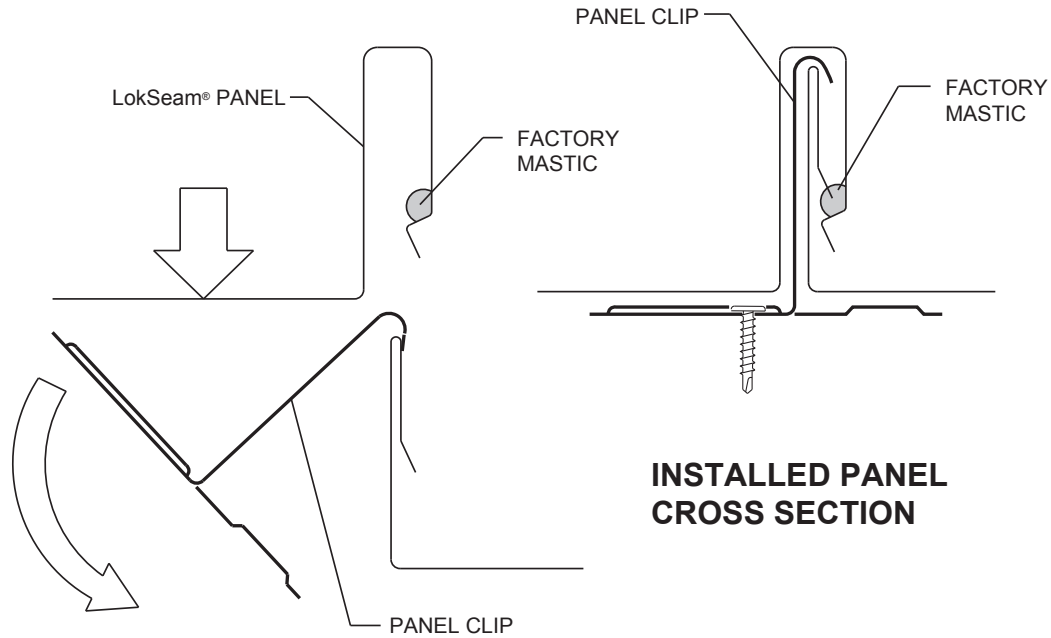

PANEL CLIP INSTALLATION

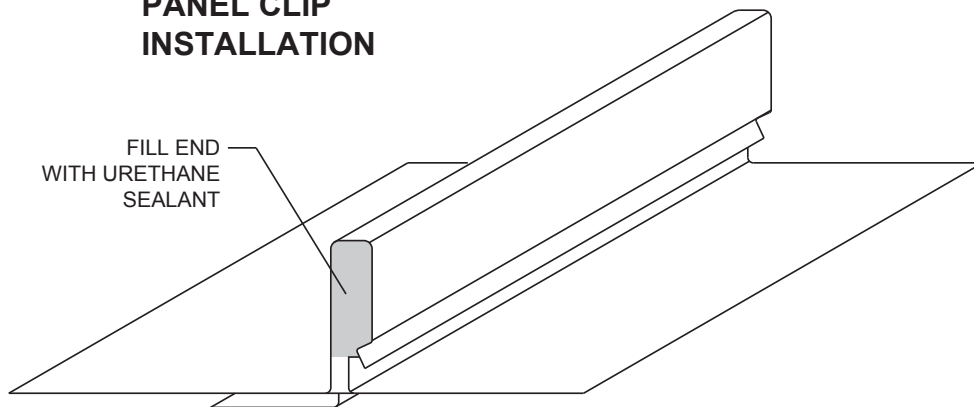

PANEL END SEALANT DETAIL

NOTES:

1. Fill end of panel seam at eave and valleys with urethane sealant.
2. For UL 90 rating, UL 90 clips with two fasteners must be used.

DETAILS

ENDLAP OVER PURLINS

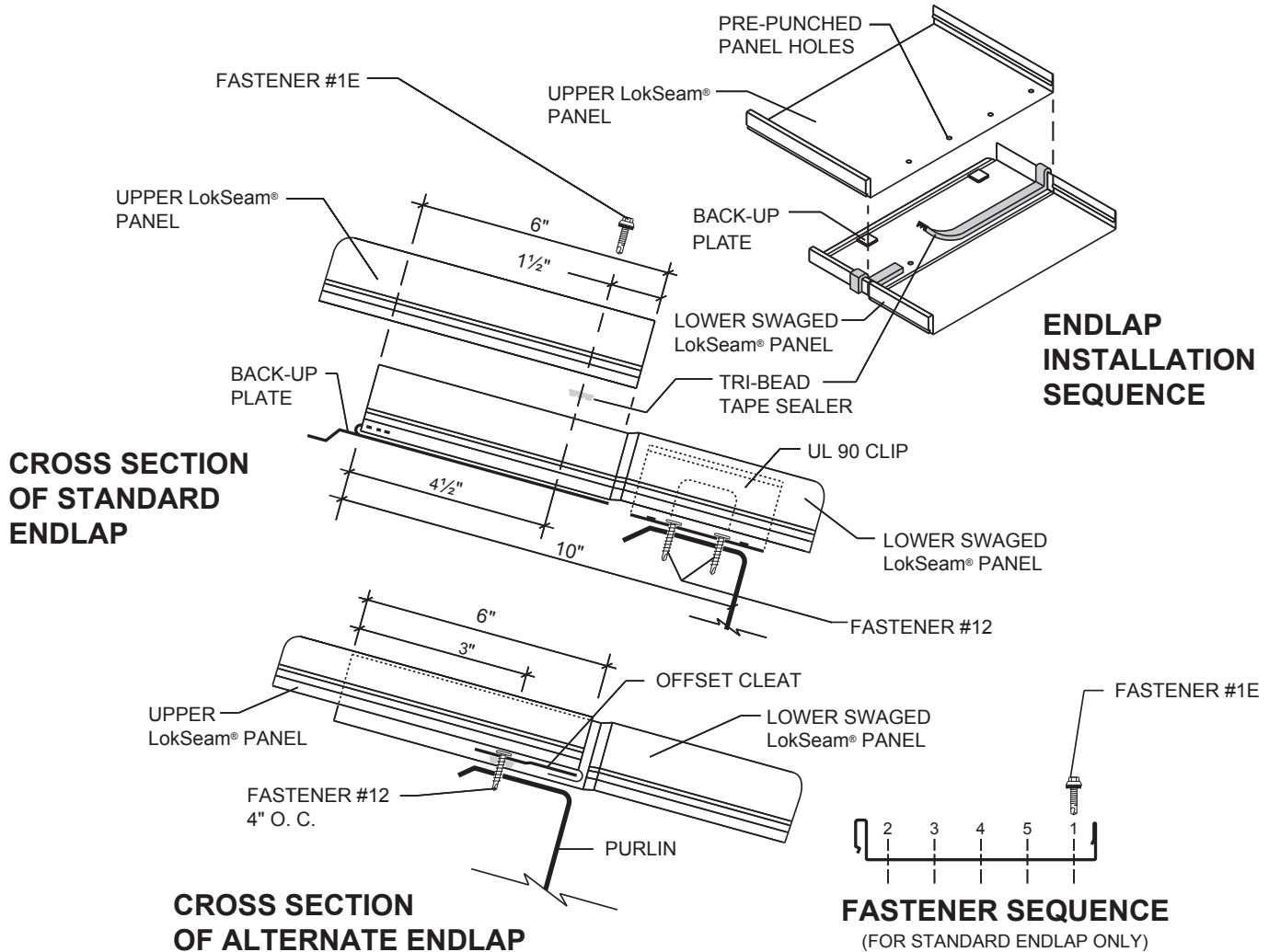

NOTES:

1. A UL 90 rating is not available on roofs over open framing with endlaps.
2. Install bottom panel so that the eave has the proper overhang (refer to eave details). The swaged, upslope end of the panel should be 10" from the web of the purlin.
3. Slide a prepunched back-up plate onto the end of the panel; make sure the teeth on top of the back-up plate are on top of the panel. Visually check to see that the holes in the back-up plate align with the prepunched holes in the panel.
4. Place Tri-Bead tape sealer over the entire width of the panel. It must be centered directly over the prepunched holes.
5. Using an awl to align the holes, install top panel by lapping it over the swaged portion of the bottom panel. Install Fastener #1E in the prepunched holes in the proper sequence.
6. Endlaps require roof erection to proceed from left to right as viewed from the eave looking toward the ridge.
7. When using the alternate endlap method, LokSeam® panels should be ordered without the prepunched endlap holes. Panels will be swaged as normal. Order the upper endlap panel 1 1/2" longer than normal for the panel hem. See Page LS-26 for ordering information.
8. When using the alternate endlap detail, use the offset cleat method of attachment at the eave or valley and the fixed detail at the ridge or hip.

DETAILS

HIP OVER PURLINS

IMPORTANT NOTE:
TEMPORARILY SECURE
PANELS AT RIDGE UNTIL
ZEE CLOSURE
IS INSTALLED

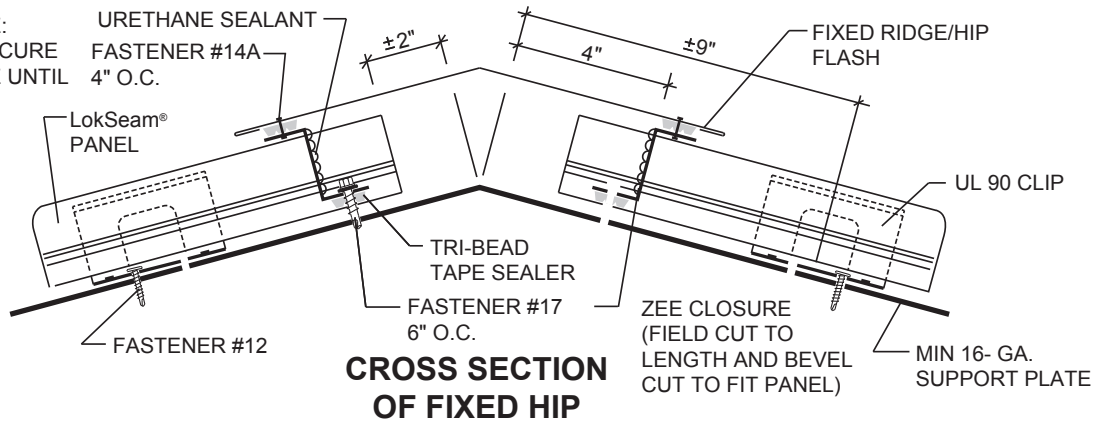

CROSS SECTION OF FIXED HIP

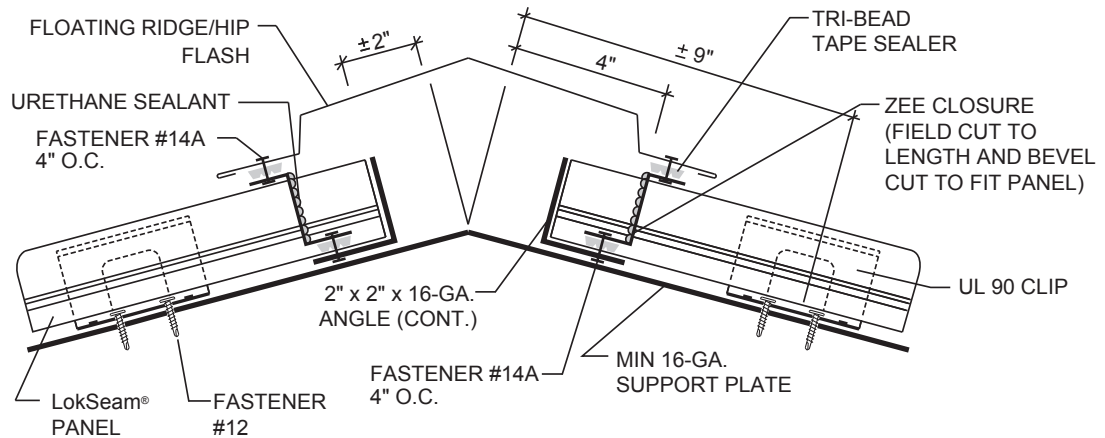

CROSS SECTION OF FLOATING HIP

NOTES:

Fixed Hip

1. **Do not use this detail with the fixed eave or valley details.**
2. Install hip support plate, notching downturned leg at purlin locations.
3. Bevel cut and install panels to follow slope of hip.
4. Install Tri-Bead tape sealer to pans of panels, running parallel to the hip. Center of tape sealer should be 3½" from the center of the hip.
5. Install zee closures to panels with Fastener #1E at 6" o.c. Vertical leg of zee closure should be 4" from center of hip.

Floating Hip

1. **Do not use this detail with the floating eave or valley details.**
2. Install hip support plate, notching downturned leg at purlin locations.
3. Bevel cut and install panels to follow slope of hip.
4. Install Tri-Bead tape sealer to panels, running parallel to the hip. Center of tape sealer should be 3½" from center of hip.
5. Slide a length of 2" x 2" x 16-gauge angle under the panels. **Do not fasten 2" x 2" angle to hip support plate. This will restrain the panels from floating.**
6. Bevel cut and install zee closures to panels and 2" x 2" angle with Fastener #14A at 4" o.c. Vertical leg of zee closure should be 4" from center of hip. Seal sides and top of zee closures to panel seams with urethane sealant.

DETAILS

RIDGE OVER PURLINS

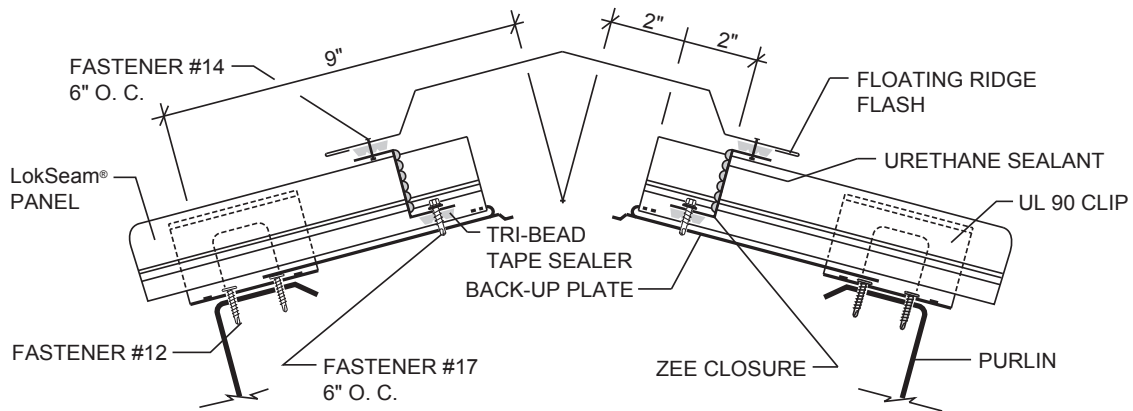

FLOATING RIDGE

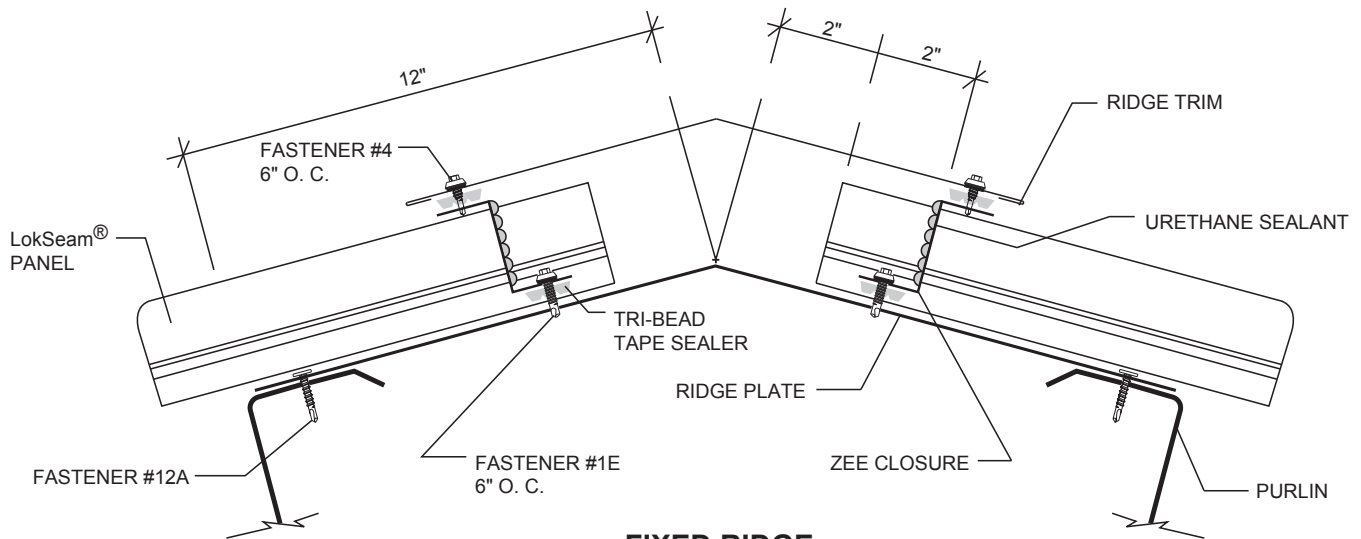

FIXED RIDGE

NOTES:

Floating Ridge

1. Do not use this detail with a floating eave or valley details.
2. Install back-up plate onto end of panel.
3. Field cut zee closures to fit panel width.
4. Install Tri-Bead tape sealer to panels. The center of tape sealer should be 1½" from end of panel.
5. Install zee closures to panels with Fastener #1E at 6" o.c. Vertical leg of zee closure should be 2" from end of panel.
6. Seal end of zee closure to panel seam with urethane sealant. Install Tri-Bead tape sealer to top of zee closure.
7. Attach ridge flash to zee closure with Fastener #4 at 6" o.c.

Fixed Ridge

1. Use this detail with a fixed eave or valley detail.
2. Field cut zee closures to fit panel width.
3. Install Tri-Bead tape sealer to panels. The center of tape sealer should be 1½" from end of panel.
4. Install zee closures to panels with Fastener #1E at 6" o.c. Vertical leg of zee closure should be 2" from end of panel.
5. Seal end of zee closure to panel seam with urethane sealant. Install Tri-Bead tape sealer to top of zee closure.
6. Attach ridge flash to zee closure with Fastener #4 at 6" o.c.

DETAILS

VENTED RIDGE OVER PURLINS

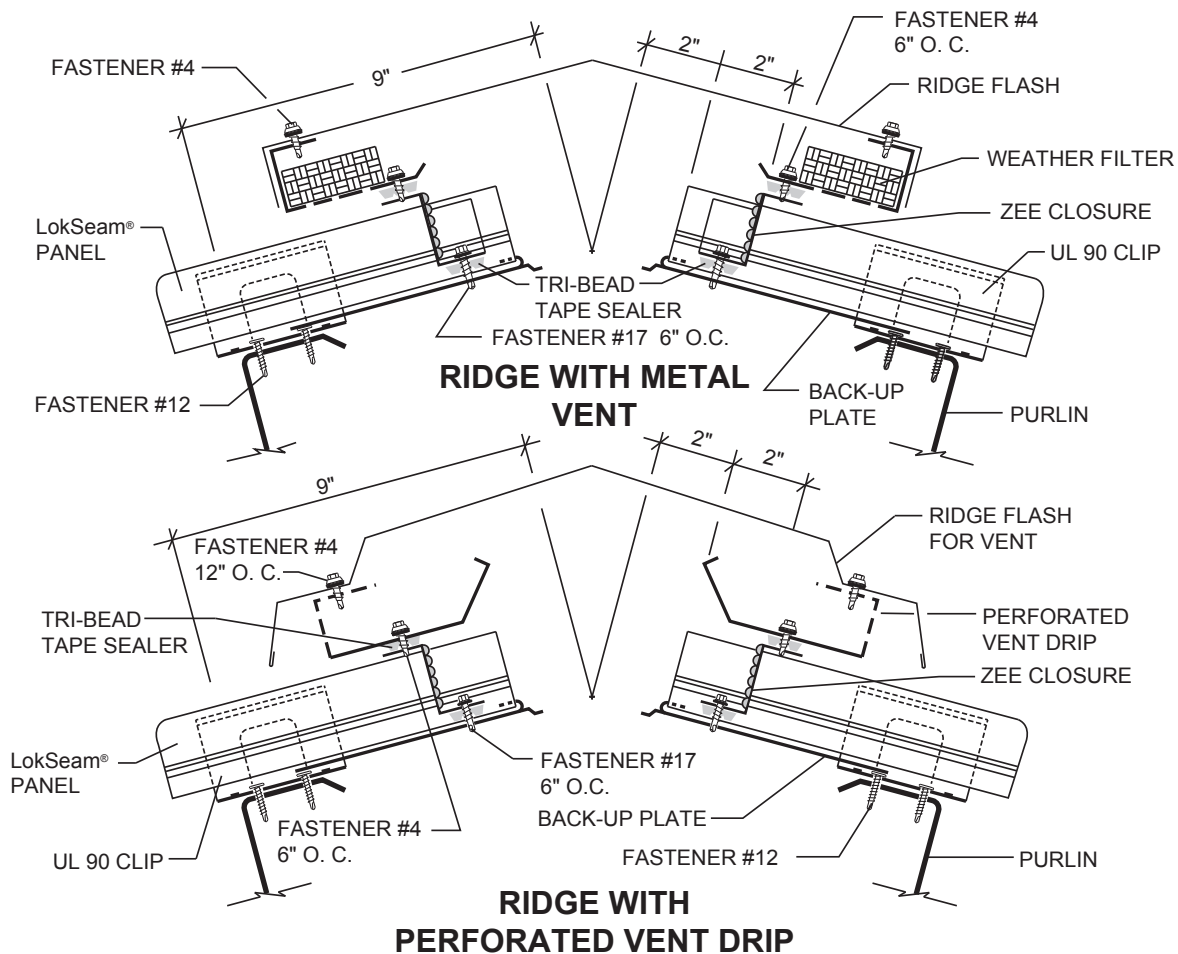

NOTES:

Ridge With Metal Vent

1. Do not use this detail with floating eave or valley details.
2. Install back-up plate onto end of panel.
3. Field cut zee closures to fit panel width.
4. Install Tri-Bead tape sealer to panels. The center of tape sealer should be 1½" from end of panel.
5. Install zee closures to panels with Fastener #1E at 6" o.c. Vertical leg of zee closure should be 2" from end of panel.
6. Seal end of zee closure to panel seam with urethane sealant. Install Tri-Bead tape sealer to top of zee closure.
7. Install vented metal to outside closures with Fastener #4 at 6" o.c.
8. Attach ridge flash with Fastener #4 at 6" o.c. to vented metal.
9. Balance vent exhaust at ridge with vent intake at eave or soffit.

Ridge With Perforated Vent Drip

1. Do not use this detail with floating eave or valley details.
 2. Vented ridge detail should be used in conjunction with soffit and/or eave vents to provide proper circulation and to prevent weather infiltration during high winds.
 3. Install back-up plate and zee closure as in Notes 2-6 above.
 4. Attach vent drip to zee closures with Fastener #4 at 6" o.c. Seal laps in vent drip with urethane sealant.
 5. Attach ridge flash to vent drip with Fastener #4 at 6" o.c.
- Metal vent material must have urethane sealant at all lap conditions.**

DETAILS

FLOATING VALLEY OVER PURLINS

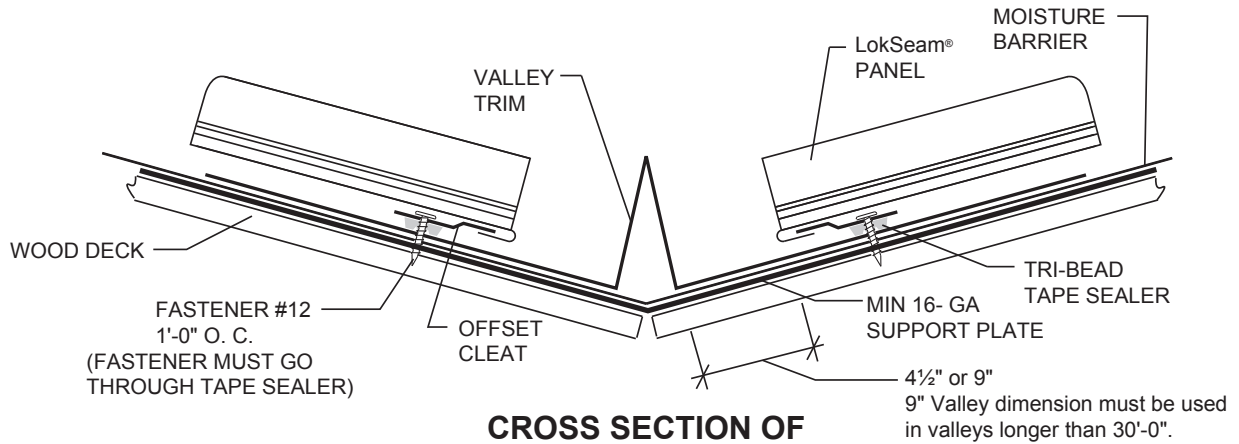

**CROSS SECTION OF
FLOATING OVER PURLINS**

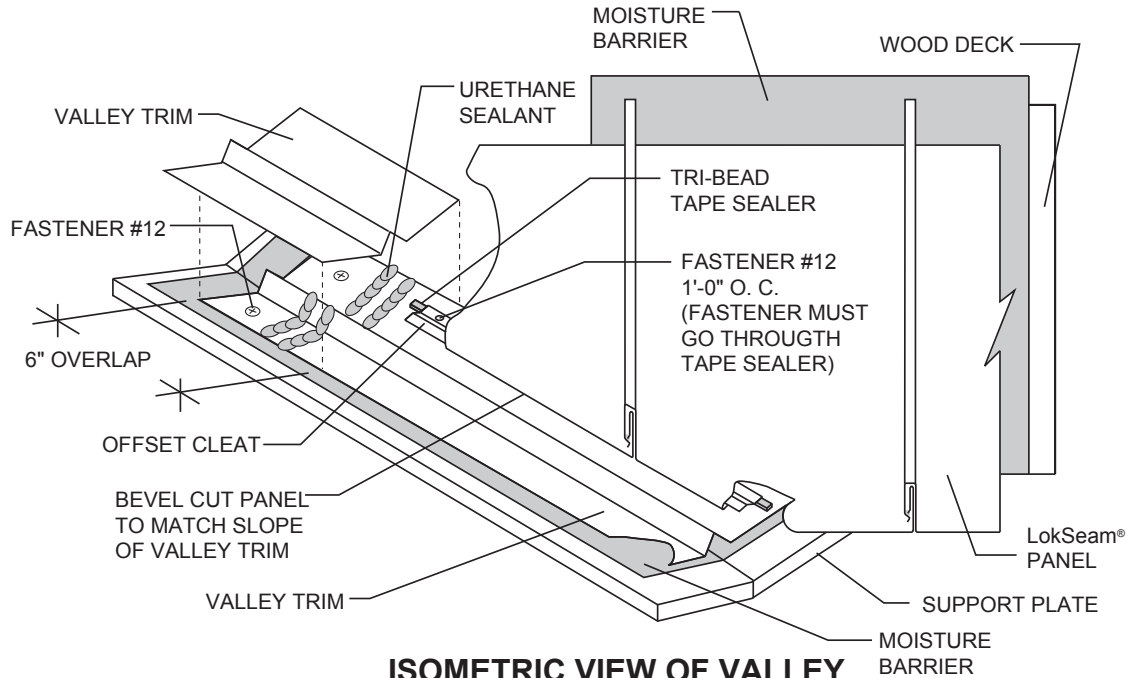

ISOMETRIC VIEW OF VALLEY

NOTES:

VALLEY WITH OFFSET CLEAT

1. For valleys longer than 30', use extended valley trim (see page LS-22).
2. **Panels must be attached to substructure at the ridge, high eave or hip to prevent them from sliding downslope.**
3. Offset cleat is installed continuous along slope of valley over Tri-bead tape sealer with Fastener #12A at 1'-0" o.c. **Fasteners must go through tape sealer.**
4. **Add 1 1/2" to panel length for the panel hem.**
5. See "Panel End Sealant Detail" on page LS-36 to seal panel ends at valley.

DETAILS

FIXED VALLEY OVER PURLINS

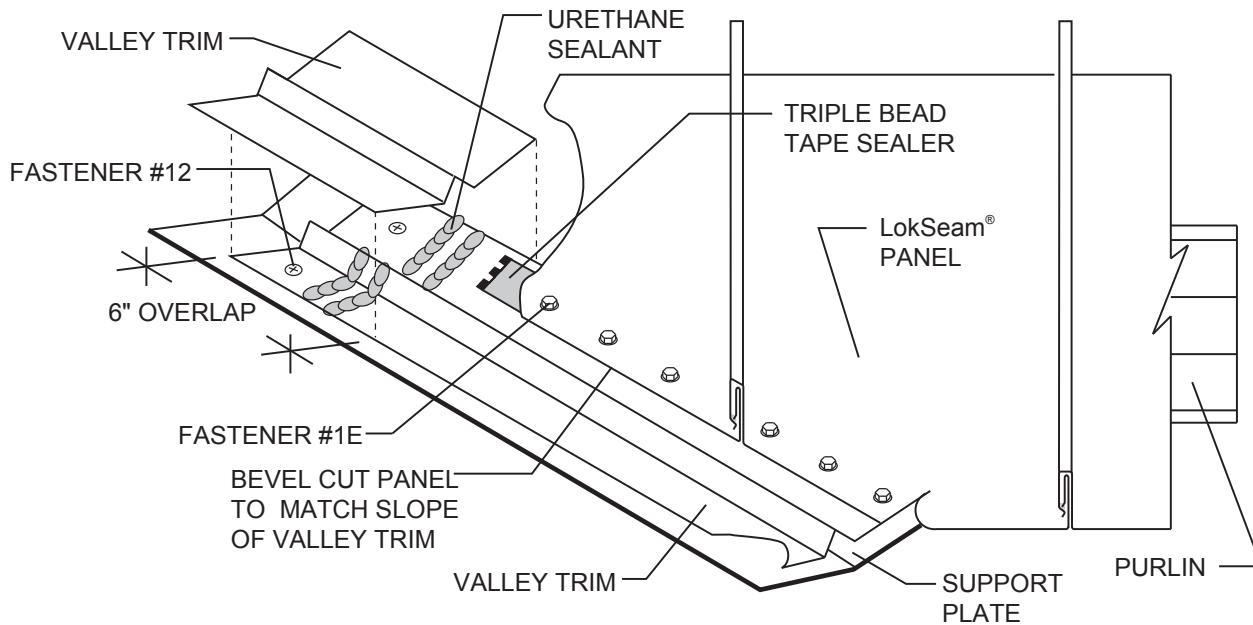
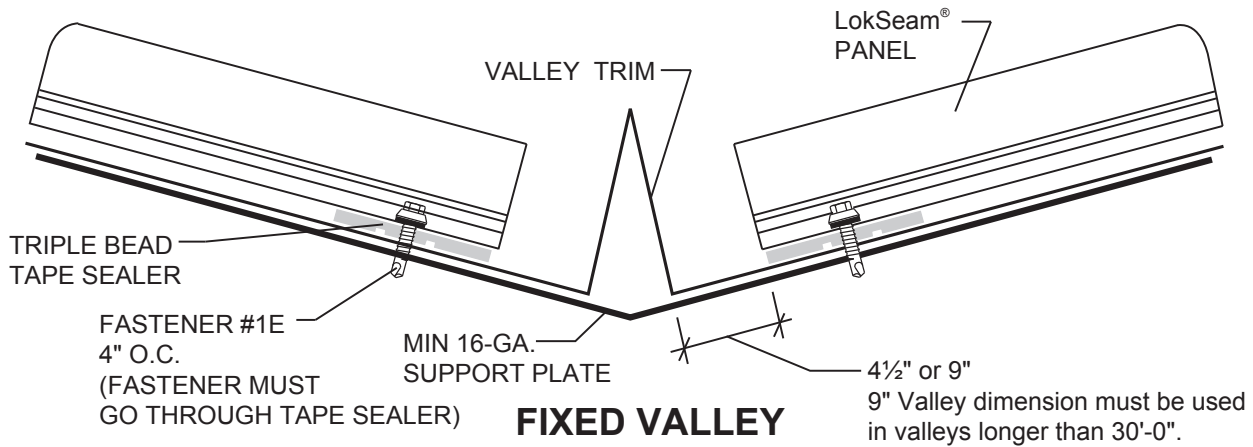

**Valley must be designed to support the panels between the purlins.
(ie: channel, angle or plate)**

NOTES:

FIXED VALLEY

1. For valleys longer than 30', use extended valley trim (see page LS-22).
2. **Do not use this detail with the fixed ridge or hip details.**
3. Ends of panels should be 4½" minimum from the vertical leg of valley trim.
4. Install Triple Bead tape sealer continuously under LokSeam® panel.
5. Attach panel to support plate with Fastener #1E at 3" o.c. **Fasteners must go through tape sealer under panel.**
6. See "Panel End Sealant Detail" on page LS-36 to seal panel ends at valley.

DETAILS

HIGH EAVE OVER PURLINS

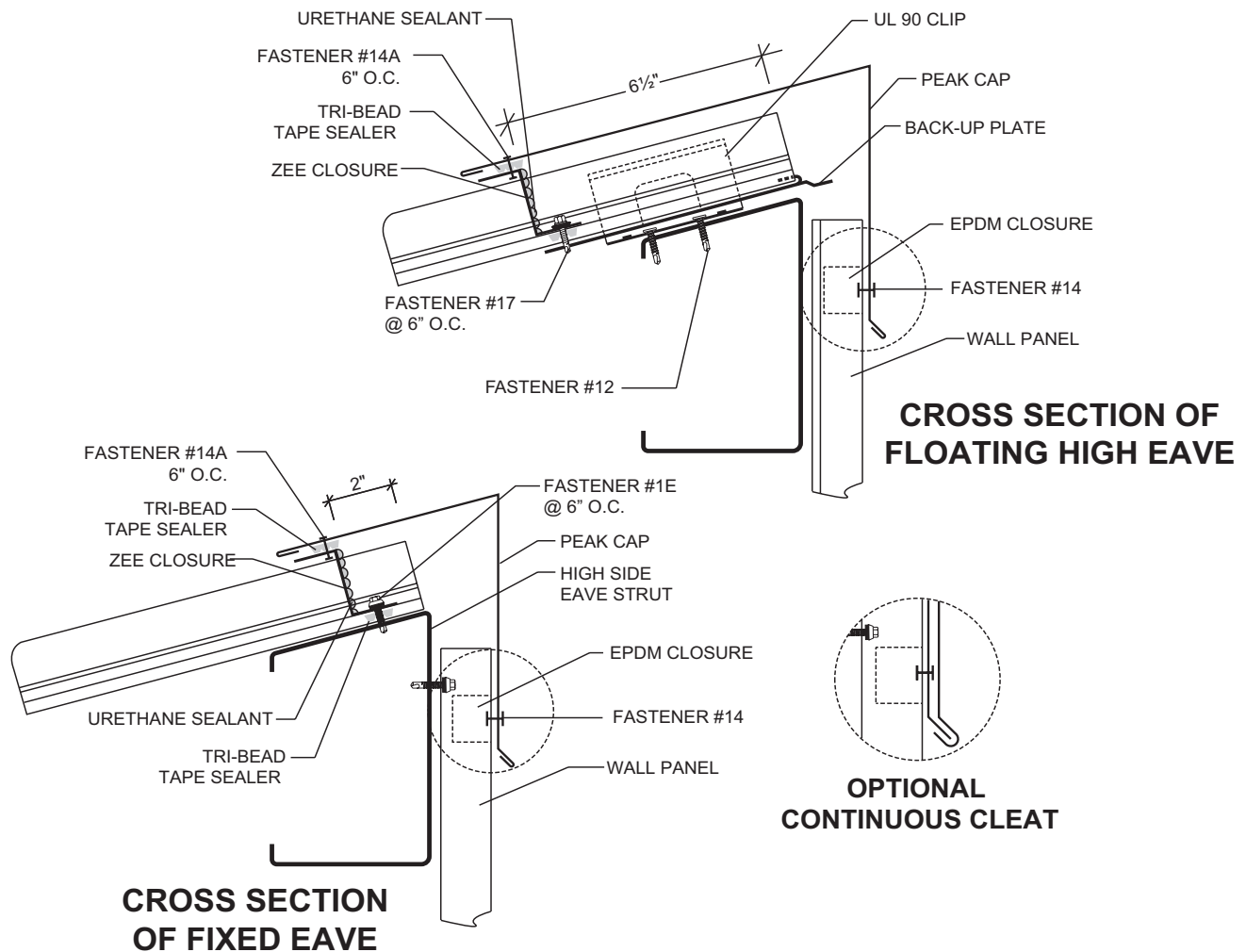

NOTES:

Floating High Eave

1. Do not use this detail with the floating eave or valley details.
2. Install panel and clips.
3. Install backup plate onto end of panel.
4. Field cut zee closures to fit panel width.
5. Install Tri-Bead tape sealer to panels. The center of tape sealer should be 6" from the end of the panel.
6. Install zee closures to panels with Fastener #1E at 6" o.c. Vertical leg of zee closure should be 6½" from end of panel.
7. Seal ends of zee closures to panel seams with urethane sealant. Install Tri-Bead tape sealer to top leg of zee closure.
8. Attach peak cap to zee closure with Fastener #14A at 6" o.c.

Fixed High Eave

1. Use this detail with a floating eave or valley detail.
2. Install panel and clips.
3. Field cut zee closures to fit panel width.
4. Install Tri-Bead tape sealer to panels. The center of tape sealer should be 1½" from the end of the panel.
5. Install zee closures to panels with Fastener #1E at 6" o.c. Vertical leg of zee closure should be 2" from end of panel.
6. Seal ends of zee closures to panel seams with urethane sealant. Install Tri-Bead tape sealer to top leg of zee closure.
7. Attach peak cap to zee closure with Fastener #14A at 6" o.c.

DETAILS

FLOATING EAVE WITH EAVE TRIM OVER PURLINS

CROSS SECTION OF EAVE TRIM WITH OFFSET CLEAT

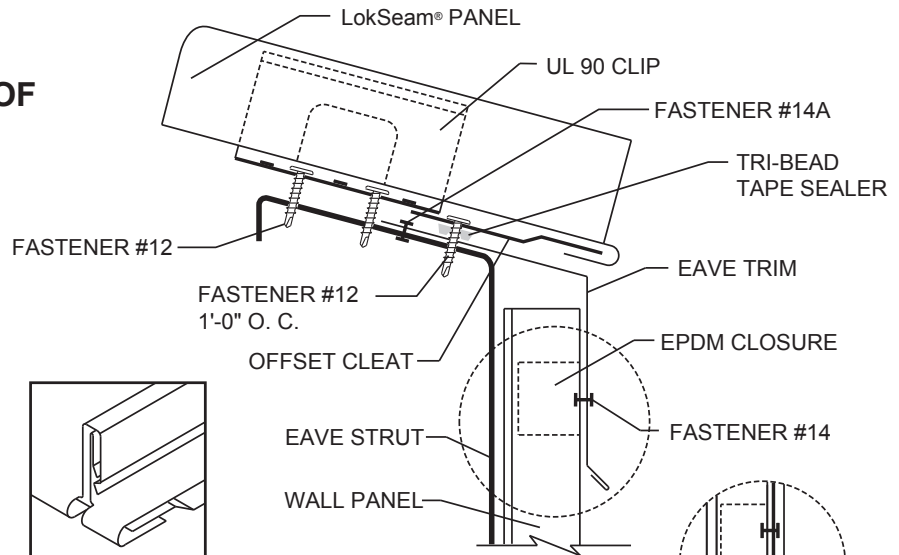

PANEL END DETAIL

SEE PAGE LS-34 FOR PANEL ENGAGEMENT

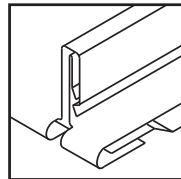

CONTINUOUS CLEAT

CROSS SECTION OF EAVE TRIM WITH EXTENDED DRIP EDGE

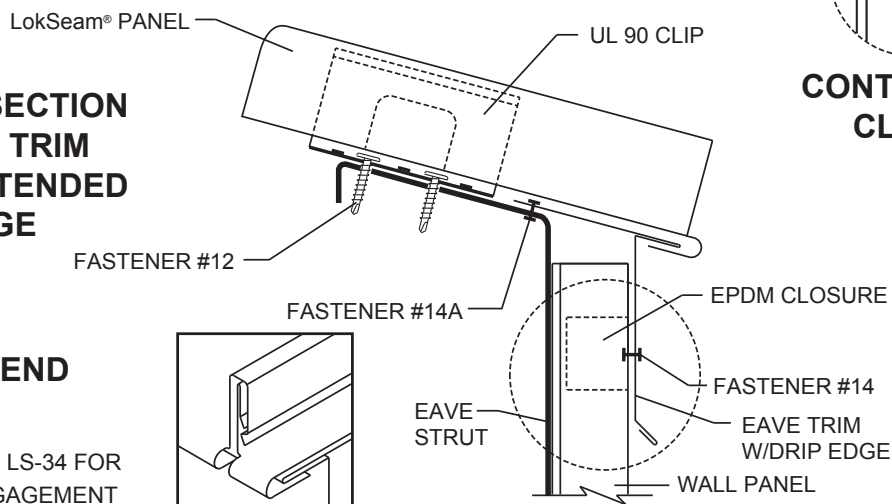

PANEL END DETAIL

SEE PAGE LS-34 FOR PANEL ENGAGEMENT

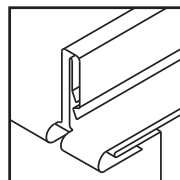

NOTES:

Eave with Offset Cleat

1. The offset cleat method of attachment should be used when ridge, high side eave or endlap is fixed to the substructure. Panels must be attached at one of these points to prevent them from sliding downslope.
2. Attach offset cleat to eave strut with Fastener #12A at 1'-0" o.c.
3. To field hem panel, see page LS-35.
4. See "Panel End Sealant Detail" on page LS-36 to seal panel ends.

Eave with Drip Edge

1. The eave with extended drip edge method of attachment should be used when ridge, high side eave or endlap is fixed to the substructure. Panels must be attached at one of these points to prevent them from sliding downslope.
2. Attach eave trim to eave strut with Fastener #14A at 2'-0" o.c.
3. To field hem panel, see page LS-35.
4. See "Panel End Sealant Detail" on page LS-36.

DETAILS

FIXED EAVE WITH EAVE TRIM OVER PURLINS

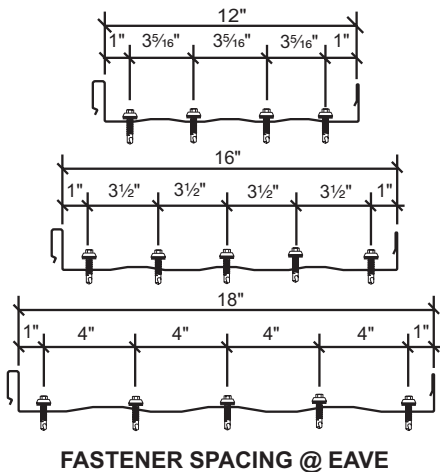

PANEL END DETAIL

FILL END OF RIB WITH
URETHANE SEALANT

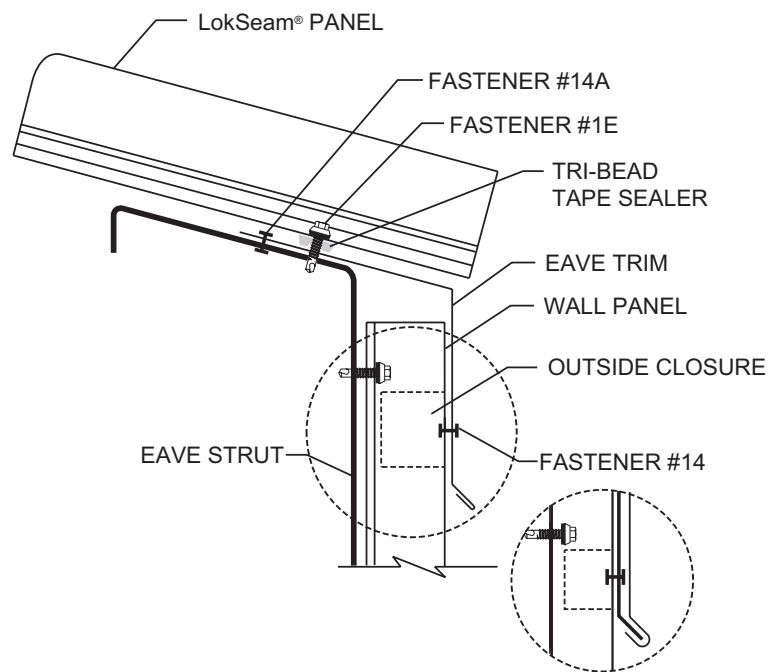
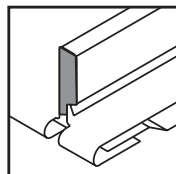

OPTIONAL CONTINUOUS CLEAT

NOTES:

1. Do not use this detail with the fixed ridge or hip details.
2. Attach eave trim to eave strut with Fastener #14A (3 fasteners per 10' piece).
3. Apply Tri-Bead tape sealer to slope leg of eave trim. Edge of tape sealer should align with edge of eave strut.
4. Install panel and fasten to eave strut with Fastener #1E at the spacing shown in the above diagram.
5. See "Panel End Sealant Detail" on page LS-36 to seal panel ends.

DETAILS

FLOATING EAVE WITH GUTTER OVER PURLINS

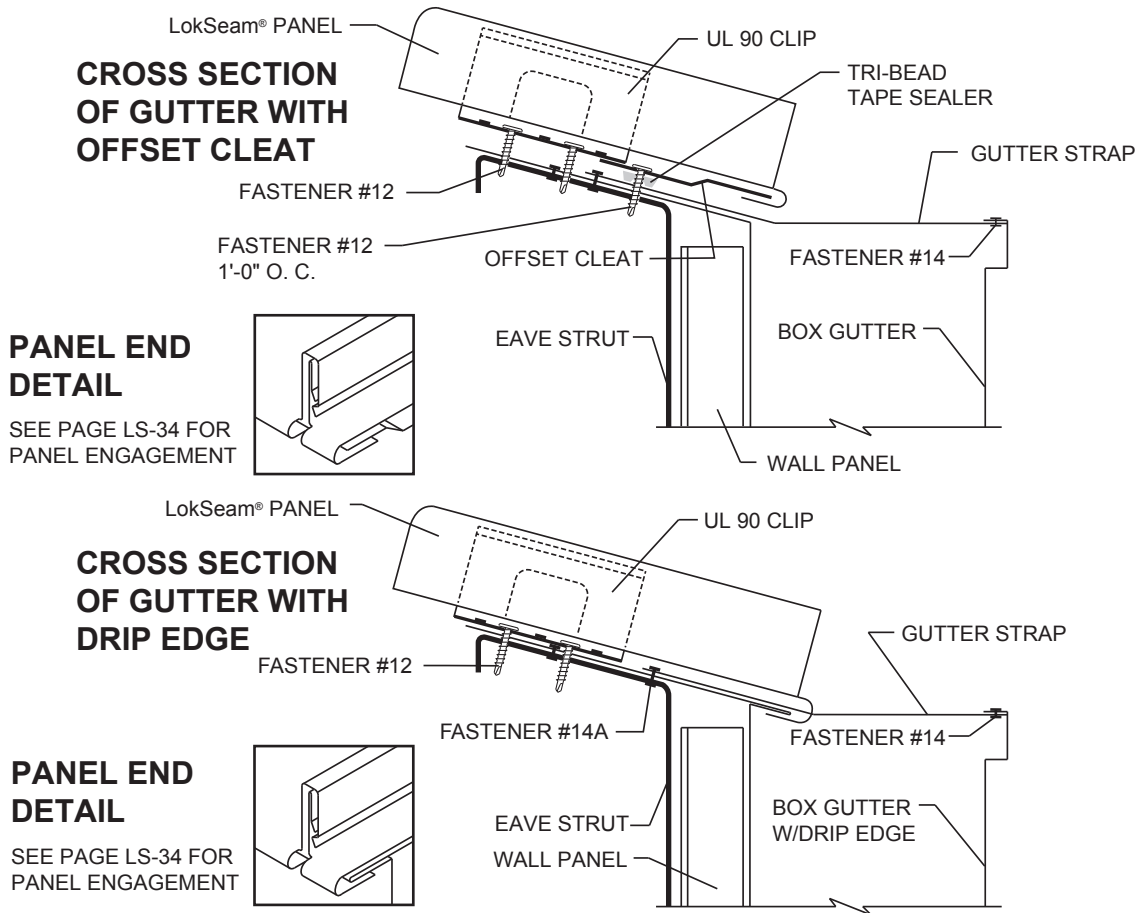

NOTES:

Offset Cleat

1. The offset cleat method of attachment should be used when ridge, high eave or endlap is fixed to the substructure.
2. Panels must be attached at one of these points to prevent them from sliding downslope.
3. Attach offset cleat to eave strut with Fastener #12A at 1'-0" o.c.
4. To field hem panel, see page LS-35.
5. See "Panel End Sealant Detail" on page LS-36 to seal panel ends.
6. The above gutter should not be used in areas that experience snow loads of 10 PSF or higher. See page LS-48 for the gutter detail for these areas.

Gutter with Drip Edge

1. The gutter with drip edge method of attachment should be used when ridge, high eave or endlap is fixed to the substructure. Panels must be attached at one of these points to prevent them from sliding downslope.
2. Install gutter to eave strut with Fastener #14A at 2'-0" o.c.
3. Attach gutter straps to gutter with Fastener #14A at 3'-0" o.c.
4. To field hem panel, see page LS-35.
5. Notch panel hem for gutter strap.
6. See "Panel End Sealant Detail" on page LS-36 to seal panel ends.
7. This detail may be used on roofs with pitches of 4:12 or less. For roofs with pitches greater than 4:12, call MBCI.
8. The above gutter should not be used in areas that experience snow loads of 10 PSF or higher. See page LS-48 for the gutter detail for these areas.

DETAILS

FIXED EAVE WITH GUTTER OVER PURLINS

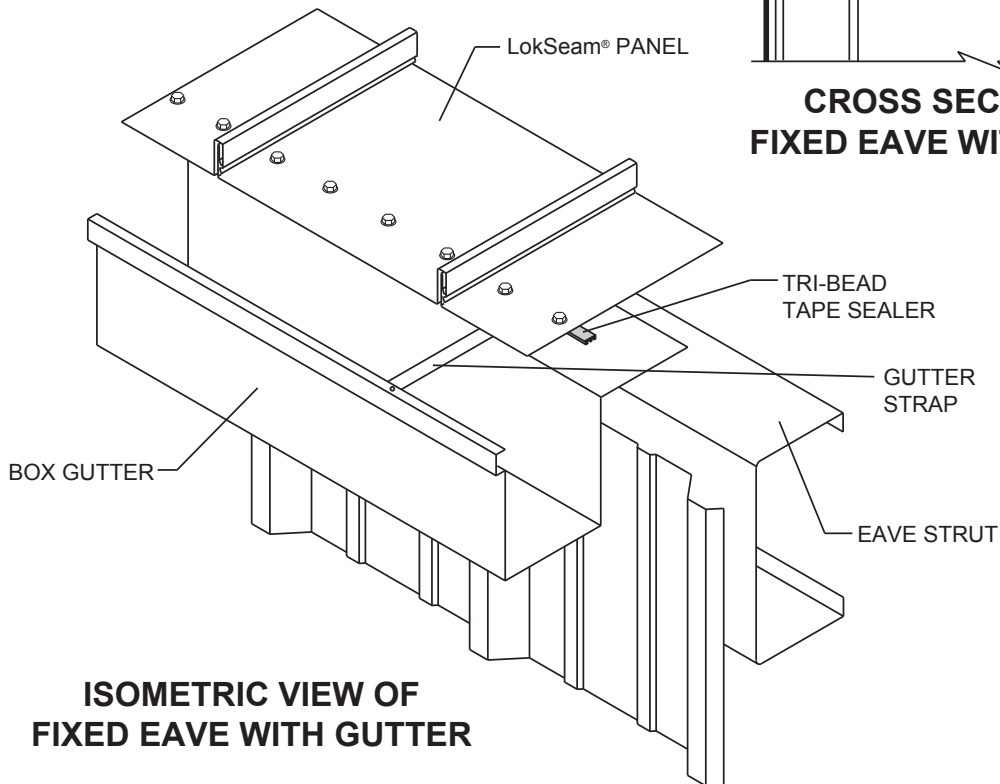
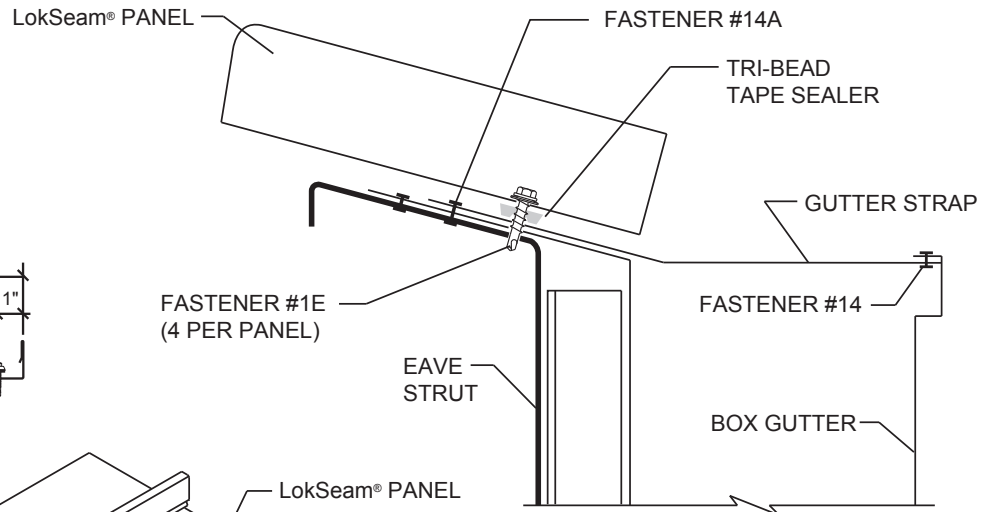
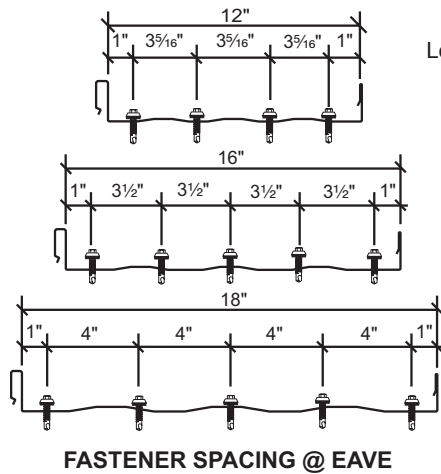

NOTES:

1. Do not use this detail with the fixed ridge or hip details.
2. Attach gutter to eave strut with Fastener #14A (3 fasteners per 10' piece).
3. Install gutter straps every 3'-0" of gutter length. Attach to outside leg of gutter and to eave strut with Fastener #14A.
4. Apply Tri-Bead tape sealer to slope leg of gutter. Edge of tape sealer should align with outside edge of eave strut.
5. Install panel and fasten to eave strut with Fastener #1E at the spacing shown in the above diagram.
6. See "Panel End Sealant Detail" on page LS-36 to seal panel ends.
7. The above gutter should not be used in areas that experience snow loads of 10 PSF or higher.

DETAILS

SNOW GUTTER OVER PURLINS

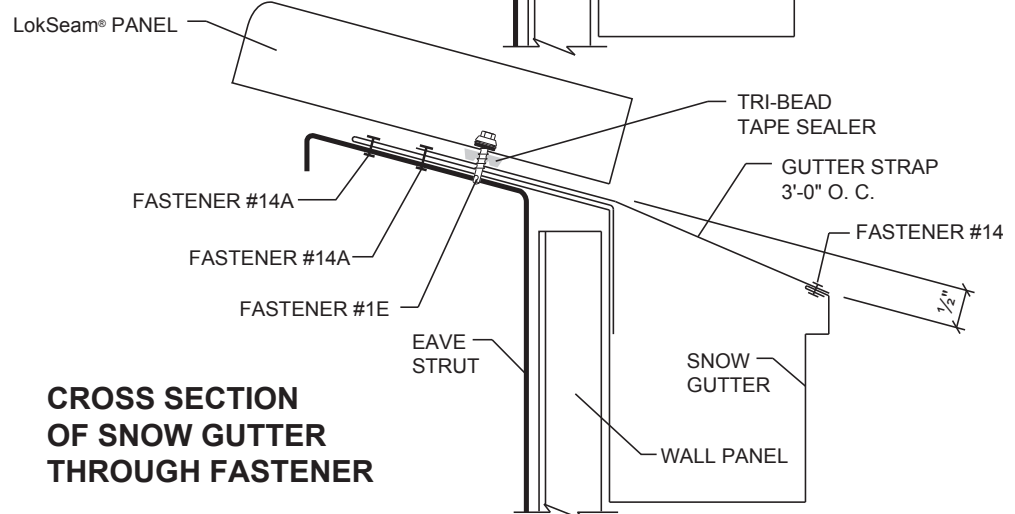
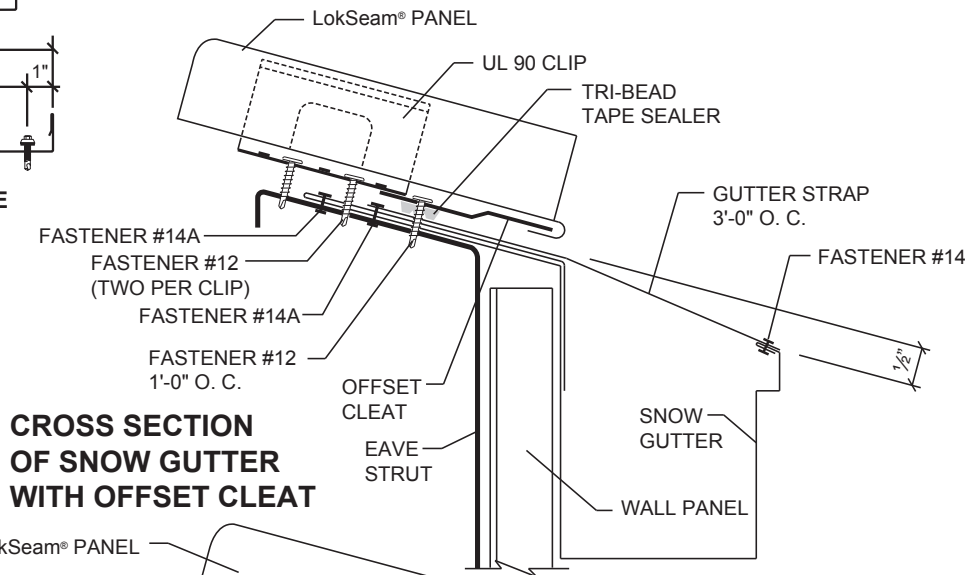
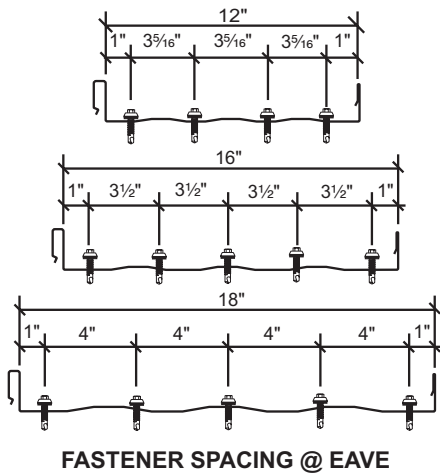
NOTES:
Through Fastened

1. Do not use this detail with the fixed ridge or hip details.
2. Attach gutter to eave strut with Fastener #14A (3 fasteners per 10' piece).
3. Attach gutter straps to gutter with Fastener #14 at 3'-0" o.c.
4. Apply Tri-Bead tape sealer to slope leg of gutter.
5. Install panel and fasten to eave strut with Fastener #1E at the spacing shown in the above diagram.
6. See "Panel End Sealant Detail at Eave" on page LS-36 to seal panel ends.

DETAILS

FLOATING RAKE OVER PURLINS

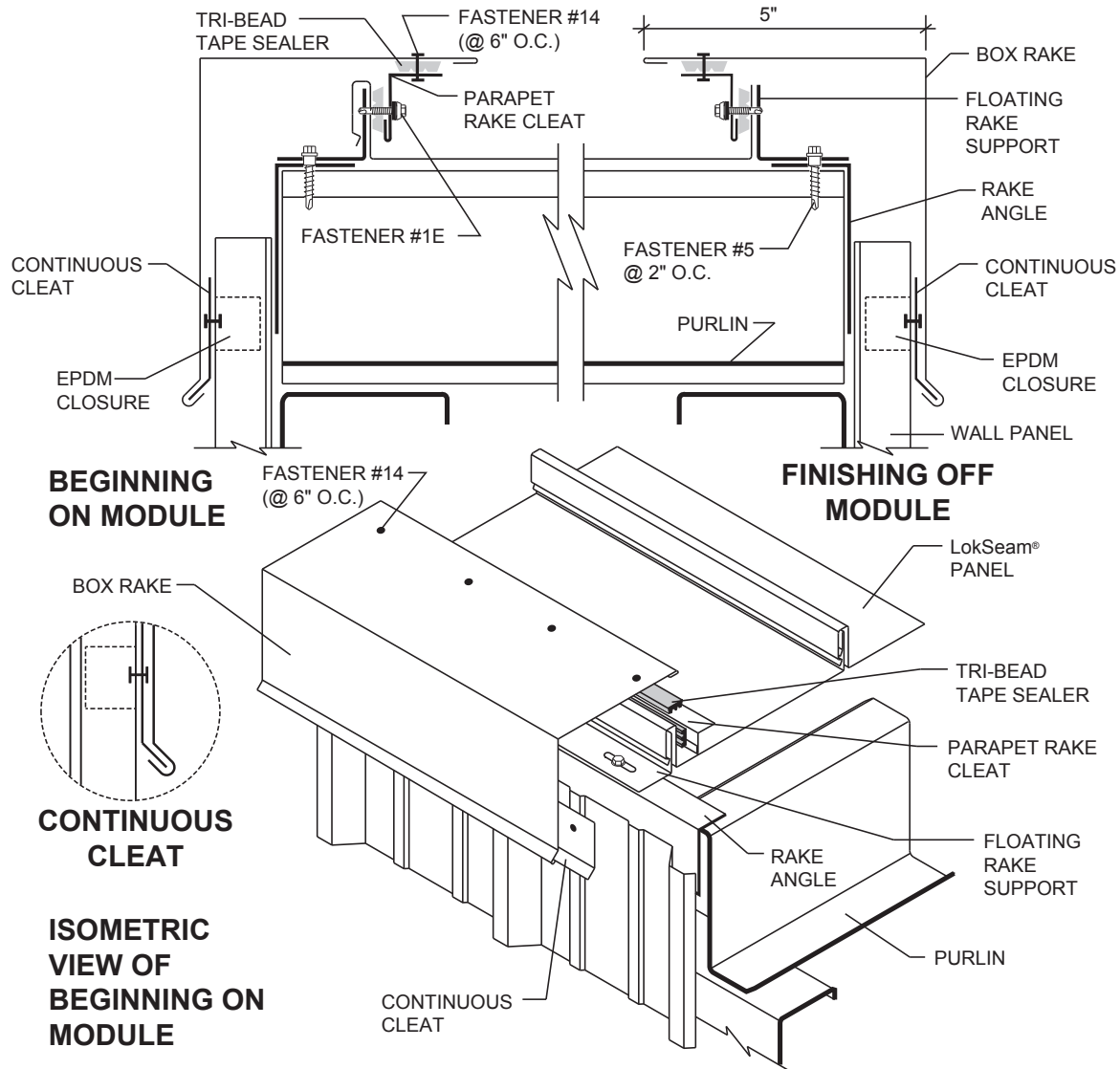

NOTES:

1. The top dimension of the rake trim will be affected by the wall panel thickness.
2. Install floating rake support with Fastener #5 at 2'-0" o.c.
3. Engage female leg of panel over rake support.
4. Apply Tri-Bead tape sealer to vertical leg of panel. Install parapet rake cleat to panel leg with Fastener #1E at 2'-0" o.c.
FASTENERS MUST GO THROUGH RAKE SUPPORT.
5. Apply Tri-Bead tape sealer to top of parapet rake cleat and attach rake trim to parapet rake cleat with Fastener #14A at 6" o.c.
6. Use continuous cleat to hold bottom of rake trim in place. Fasten continuous cleat to each high rib of wall panel.
7. If roof finishes on module, finishing detail will be similar to starting detail. If roof finishes off module, field cut and bend last panel run to fit against floating rake support. Install parapet rake cleat, tape sealer and rake trim as previously described.
8. If rake trim is not to be immediately installed, temporarily fasten panels to rake support to prevent wind damage.

DETAILS

PARAPET HIGH EAVE OVER PURLINS

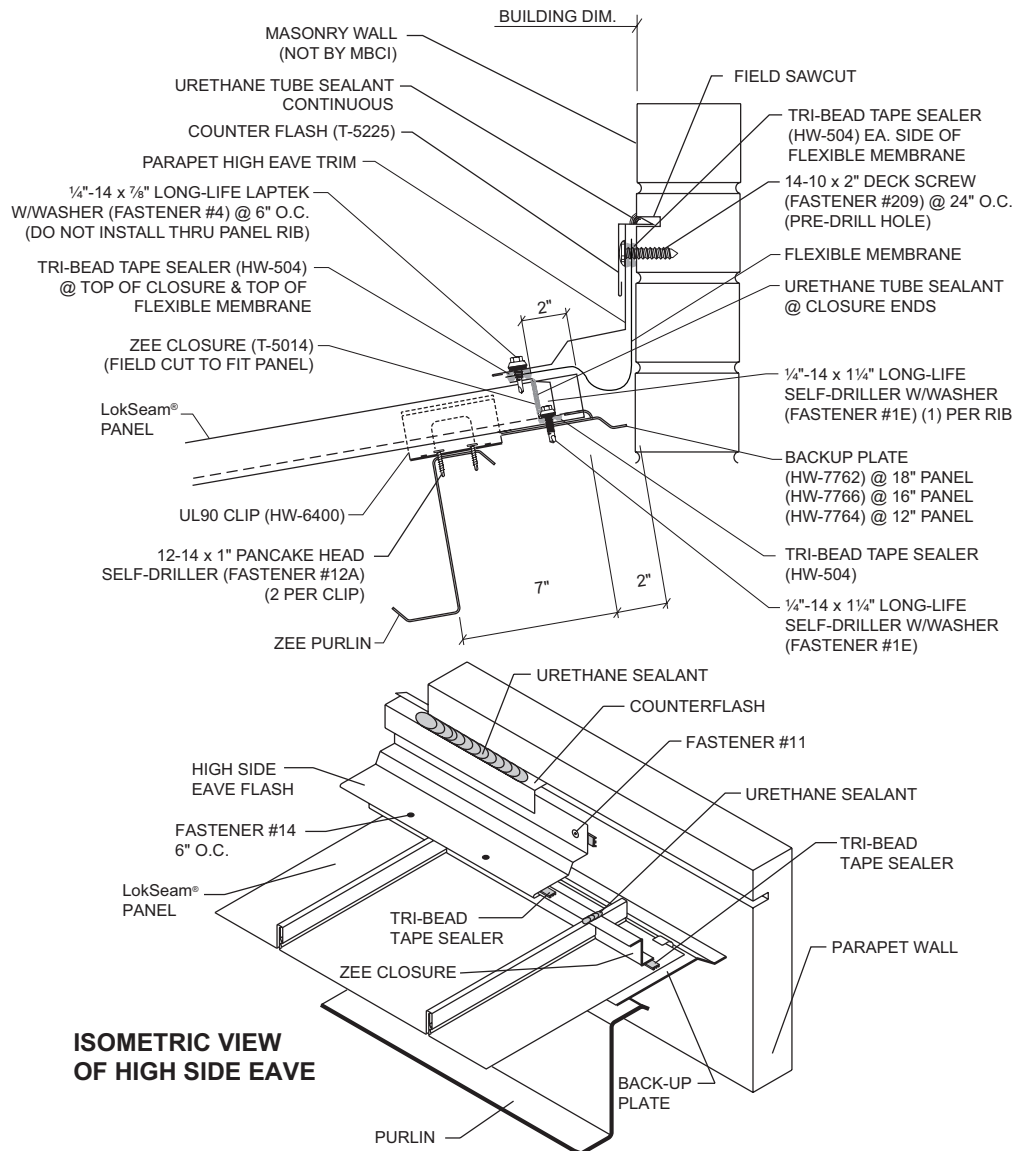

NOTES:

Floating Parapet High Eave

1. Do not use this detail with the floating eave or valley details.
2. Install back-up plate onto end of panel.
3. Field cut zee closures to fit panel width.
4. Apply Tri-Bead tape sealer to panels. Center of tape sealer should be 1½" from end of panel.
5. Install zee closures to panels with Fastener #1E at 6" o.c. Vertical leg of zee closures should be zee from end of panels.
6. Seal ends of zee closures to the panel seams with urethane sealant. Apply Tri-Bead tape sealer to the top leg of zee closures.
7. Attach parapet high side eave trim to zee closure with Fastener #4A at 6" o.c.
8. Seal counterflash to parapet wall with urethane sealant.

Fixed Parapet High Eave

1. Use this detail with a floating eave or valley detail.
2. Install panels and clips.
3. Field cut zee closures to fit panel width.
4. Install Tri-Bead tape sealer to panels. The center of the tape sealer should be 1½" from end of panel.
5. Install zee closures to panels with Fastener #1E at 6" o.c. Vertical leg of zee closures should be 2" from end of panels.
6. Seal ends of zee closures to the panel seams with urethane sealant. Apply Tri-Bead tape sealer to the top leg of zee closures.
7. Attach parapet high side eave trim to zee closure with Fastener #4A at 6" o.c.

DETAILS

FLOATING PARAPET RAKE OVER PURLINS

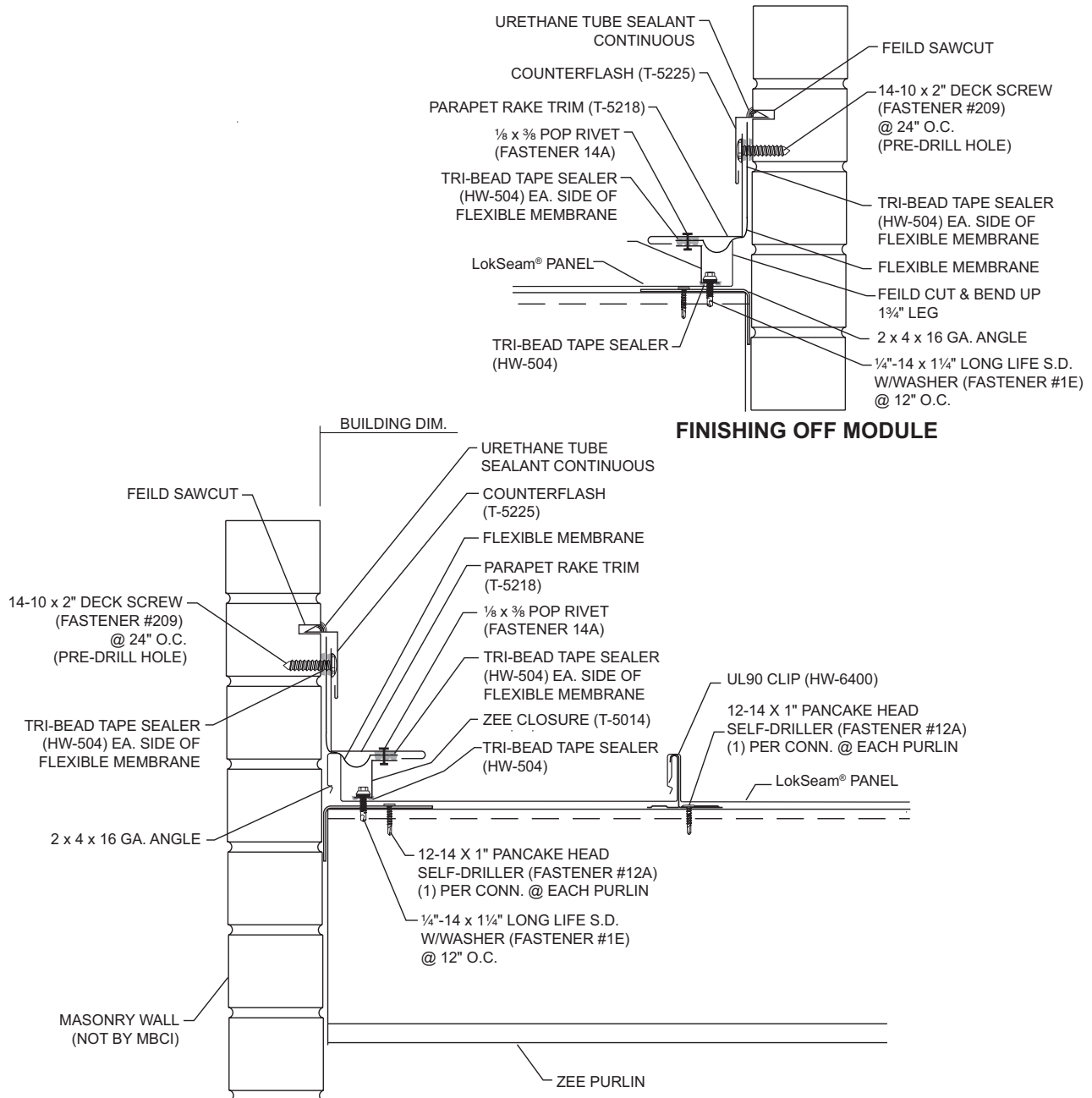

NOTES:

1. Install floating rake support with Fastener #5 at 2'-0" o.c. Fasteners must be installed in center of slot.
2. Engage female leg of panel over rake support.
3. Apply Tri-Bead tape sealer to vertical leg of panel. Install flexible membrane and parapet rake cleat to panel leg with Fastener #1E at 2'-0" o.c. **FASTENERS MUST GO THROUGH RAKE SUPPORT.**
4. Engage open hem of parapet rake flash onto parapet rake cleat and fasten top leg to parapet wall with Fastener #11.
5. If roof finishes on module, finishing detail will be similar to starting detail. If roof finishes off module, field cut and bend last panel run to fit against floating rake support. Install parapet rake cleat, tape sealer, and parapet rake flash as previously described.
6. If parapet rake flash is not to be immediately installed, temporarily fasten panels to rake support to prevent wind damage.

DETAILS

ROOF TRANSITION OVER PURLINS

CROSS SECTION OF ROOF TRANSITION

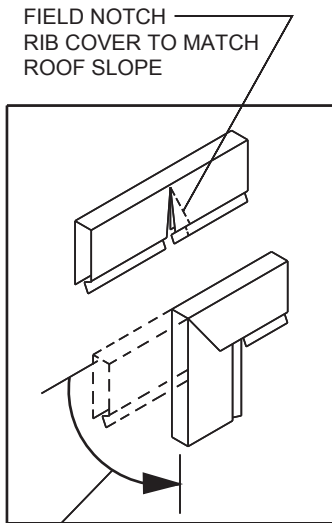

BEND RIB
COVER AND
INSTALL ON
PANEL

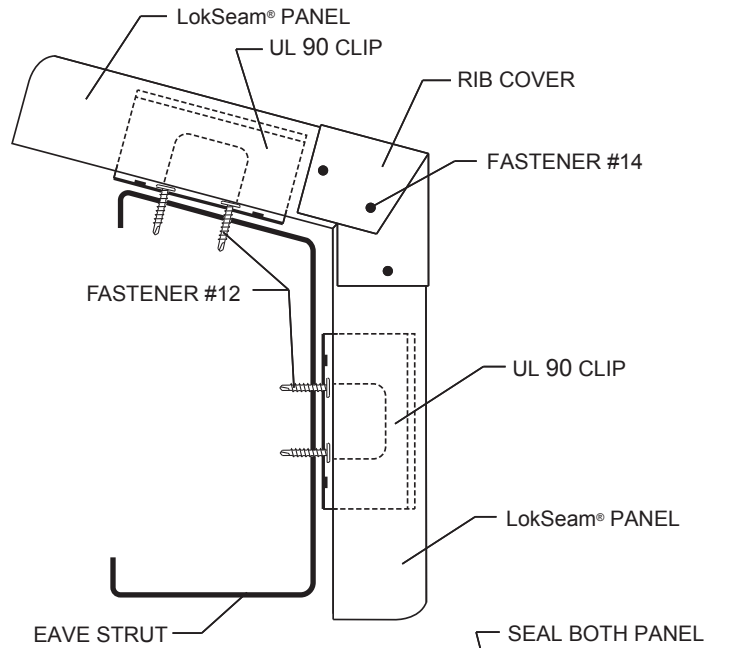

SEAL BOTH PANEL
ENDS WITH
URETHANE SEALANT

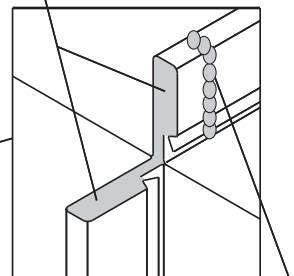

URETHANE SEALANT

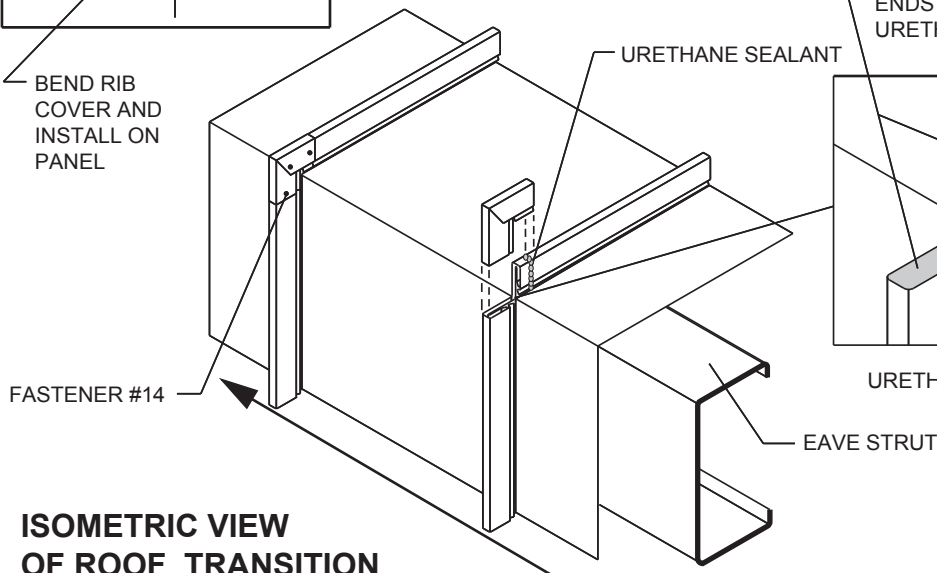

ISOMETRIC VIEW OF ROOF TRANSITION

INSTALLATION DIRECTION

NOTES:

1. Do not use this detail with the fixed ridge or hip details.
2. Field cut legs of panels and bend to required angle.
3. Fill both exposed ends of panel with urethane sealant.
4. Field notch rib cover to allow it to bend to the proper angle.
5. Field apply a bead of urethane sealant over rib before applying rib cover.
6. **Do not use this detail inside the building envelope.**

DETAILS

ENDLAP OVER WOOD DECK

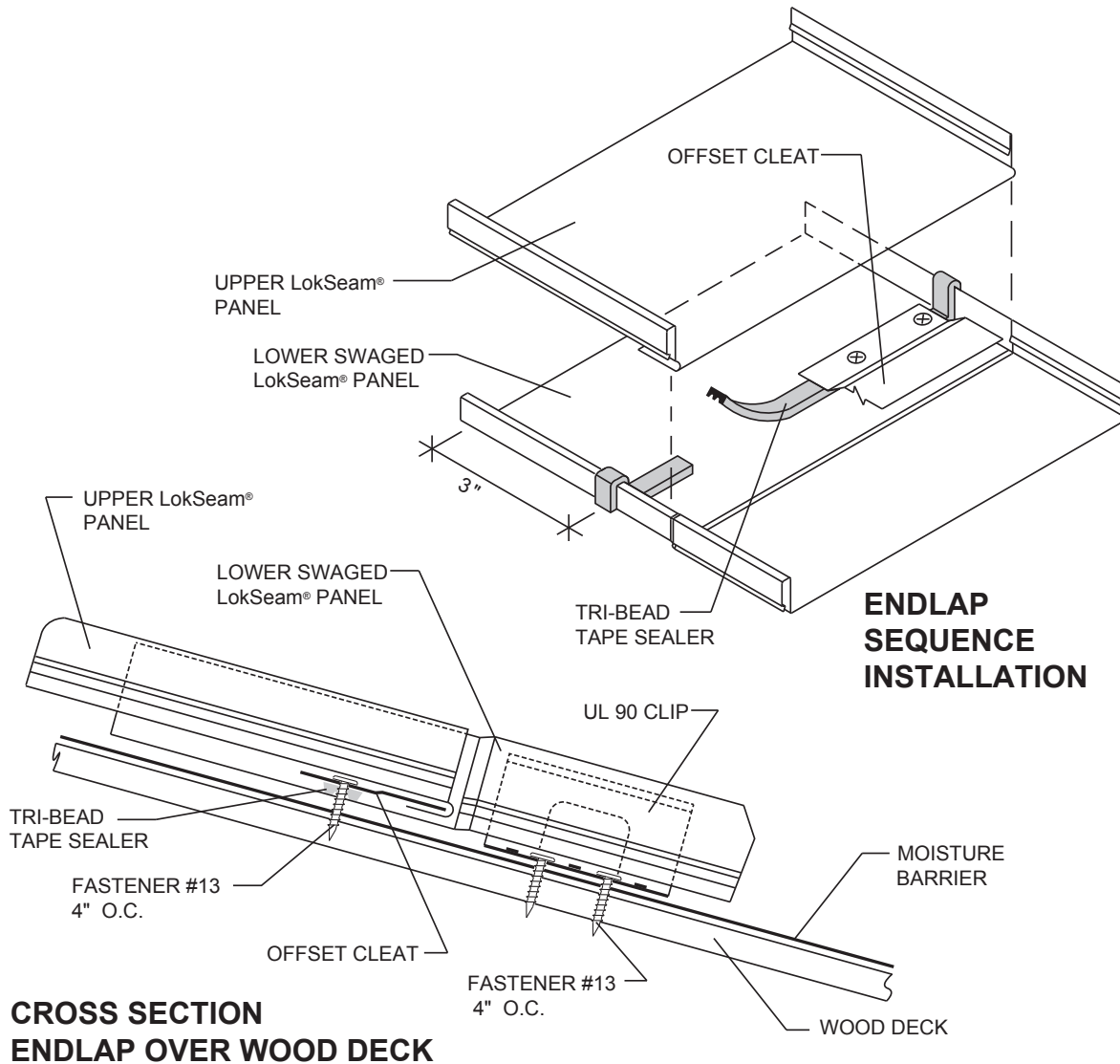

NOTES:

1. The above endlap detail must be used with the floating eave or valley details. The fixed detail must be used at the ridge or hip. The above detail also requires that the LokSeam® panels be ordered without prepunched endlaps. Panels will be swaged as normal. Order the upper endlap panel 1/2" longer than normal for the panel hem. See Page LS-26 for ordering information.
2. Install bottom panel so that eave has proper overhang (refer to Eave Details).
3. At upslope end of bottom panel, place Tri-Bead tape sealer over entire width of panel. Center of tape sealer should be 4 1/2" from end of panel.
4. Install offset cleat across width of panel (over tape sealer) with Fastener #13A at 4" o.c. **Fasteners must go through tape sealer.**
5. Field notch male and female legs of panel 1 1/2" and bend panel to form an open hem.
6. Clip spacing should not exceed 4'-0" o.c. for 24-gauge panels or 5'-0" o.c. for 22-gauge panels

DETAILS

HIP OVER WOOD DECK

IMPORTANT NOTE:
TEMPORARILY SECURE
PANELS AT RIDGE UNTIL
ZEE CLOSURE
IS INSTALLED

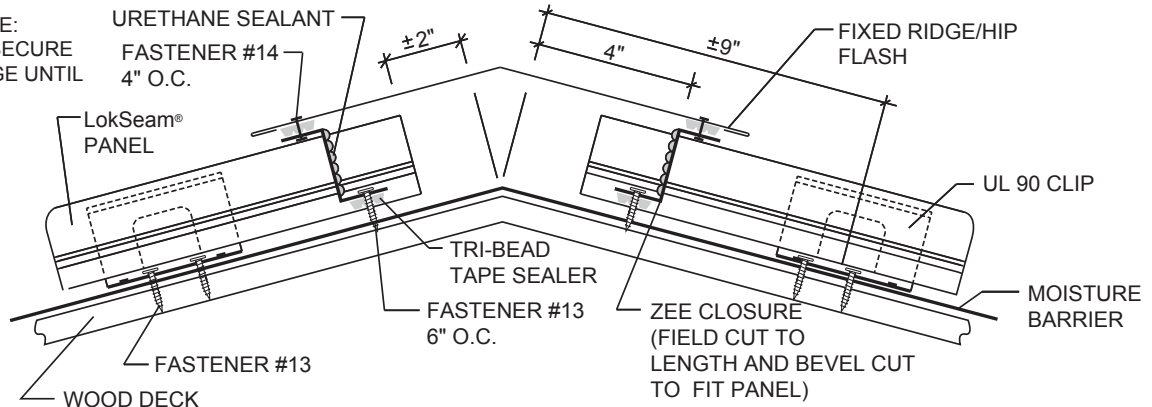

STANDARD FIXED HIP OVER WOOD DECK

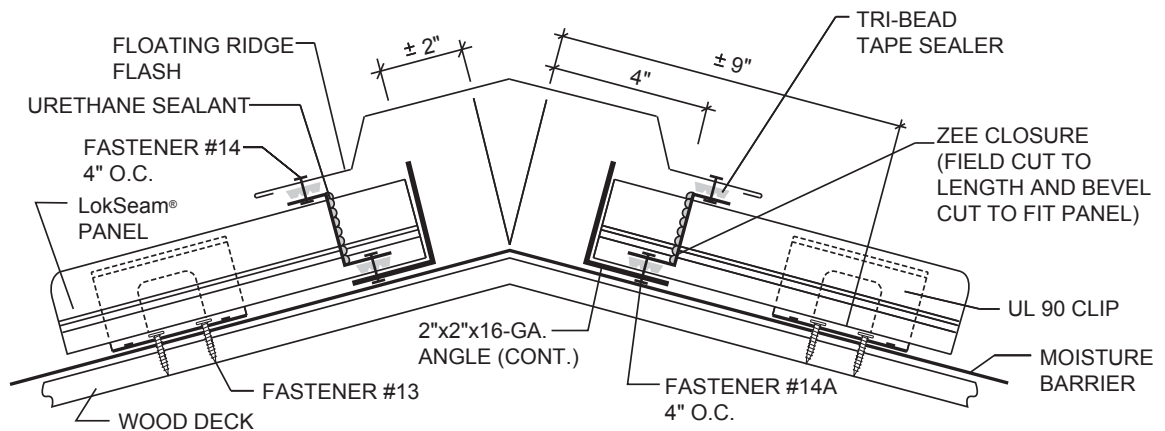

STANDARD FLOATING RIDGE/HIP OVER WOOD DECK

NOTES:

Fixed Hip

1. Do not use this detail with the fixed eave or valley details.
2. Bevel cut and install panels to follow slope of hip.
3. Install Tri-Bead tape sealer to panels, running parallel to the hip. Center of tape sealer should be 3½" from the center of the hip.
4. Install zee closures to panels with Fastener #13A at 6" o.c. Vertical leg of zee closure should be 4" from center of hip.

Floating Hip

1. Do not use this detail with the floating eave or valley details.
2. Field cut zee closures to fit panel width.
3. Install Tri-Bead tape sealer to panels. Center of tape sealer should be 1½" from end of panel.
4. Slide a length of 2" x 2" x 16-gauge angle under the panels.
5. Install zee closures to panels and 2" x 2" angle with Fastener #14A at 4" o.c. Vertical leg of zee closure should be 4" from center of ridge. Seal sides of zee closures to panel seams with urethane sealant.

DETAILS

FIXED RIDGE OVER WOOD DECK

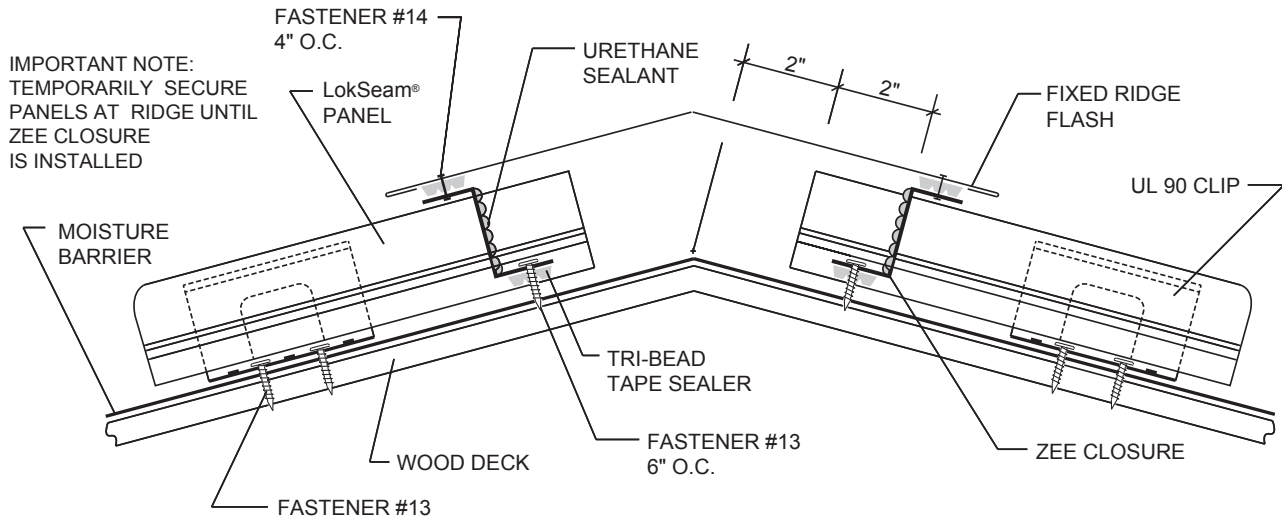

STANDARD RIDGE OVER WOOD DECK

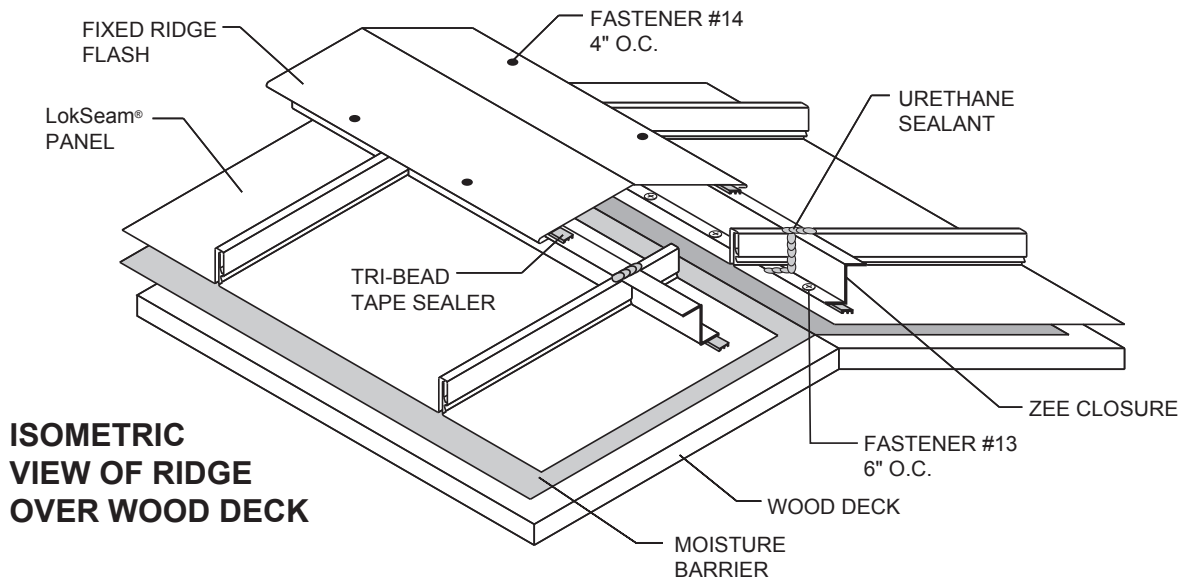

ISOMETRIC VIEW OF RIDGE OVER WOOD DECK

NOTES:

1. Do not use this detail with the fixed eave or valley details.
2. Field cut zee closures to fit panel width.
3. Install Tri-Bead tape sealer to panels. Center of tape sealer should be 1½" from end of panel.
4. Install zee closures to panels with Fastener #13A at 6" o.c. Vertical leg of zee closure should be 2" from end of panel. Fasteners must go through tape sealer.
5. Seal end of zee closure to panel seams with urethane sealant.
6. Clip spacing should not exceed 4'-0" o.c. for 24-gauge panels or 5'-0" o.c. for 22-gauge panels.

DETAILS

FLOATING RIDGE OVER WOOD DECK

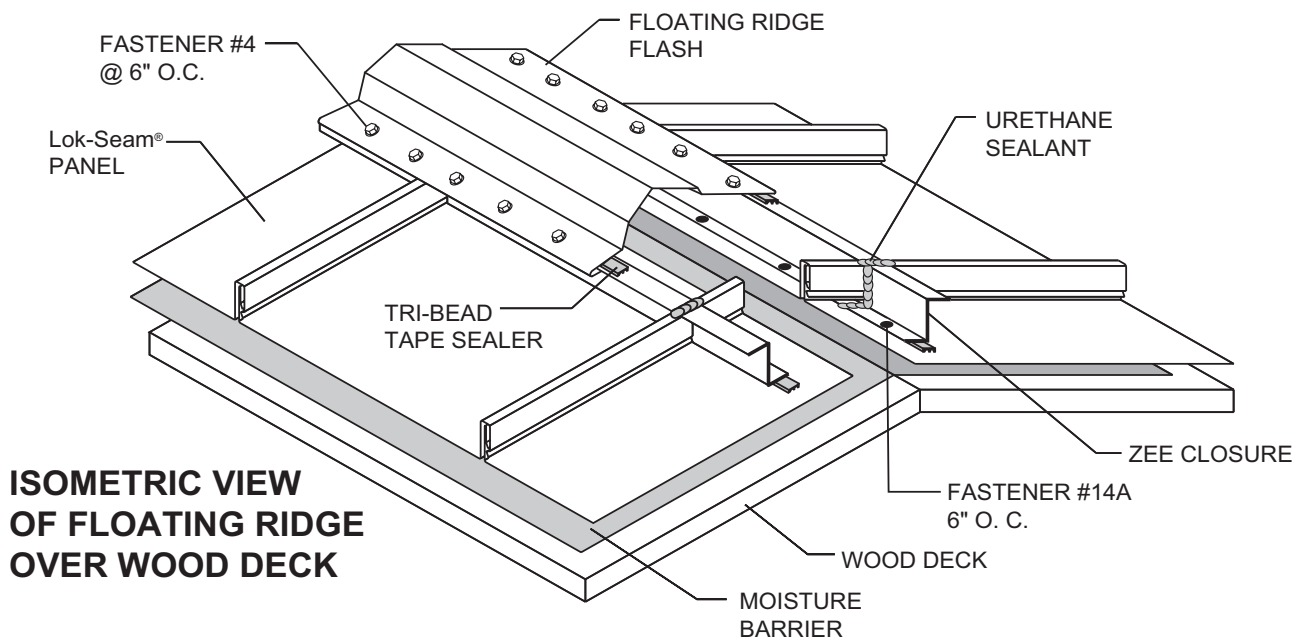
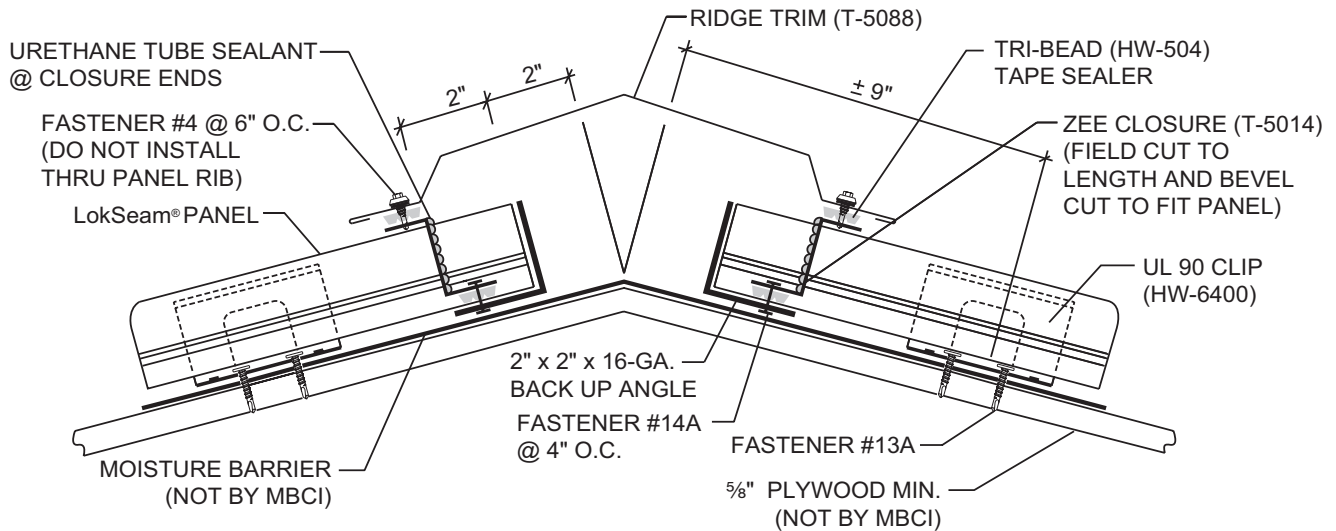

ISOMETRIC VIEW OF FLOATING RIDGE OVER WOOD DECK

NOTES:

1. Do not use this detail with floating eave or valley details.
2. Field cut zee closures to fit panel width.
3. Install Tri-Bead tape sealer to panels. The center of tape sealer should be 1 1/2" from end of panel.
4. Slide a length of 2" x 2" x 16 gauge angle under the panels.
5. Install zee closures to panels and 2" x 2" angle with Fastener #14A at 4" o.c. Vertical leg of zee closure should be 4" from center of ridge. Seal sides of zee closures to panel seams with urethane sealant.

DETAILS

VENTED RIDGE OVER WOOD DECK

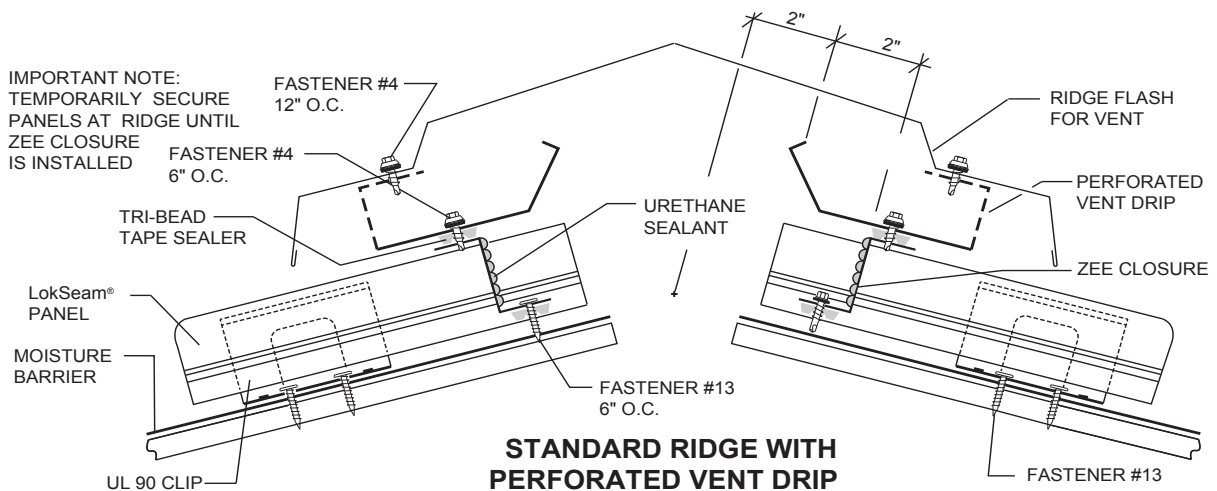

STANDARD RIDGE WITH PERFORATED VENT DRIP

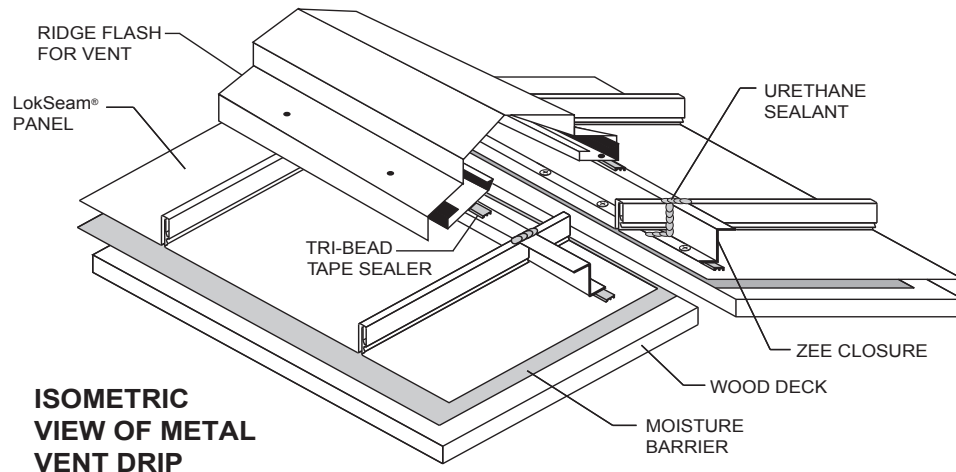

ISOMETRIC VIEW OF METAL VENT DRIP

NOTES:

Ridge With Perforated Vent Drip

1. Do not use this detail with the fixed eave or valley details.
2. Field cut zee closures to fit panel width.
3. Install Tri-Bead tape sealer to panels. Center of tape sealer should be 1½" from end of panel.
4. Install zee closures to panels with Fastener #13A at 6" o.c. Vertical leg of zee closure should be 2" from end of panel. Fasteners must go through tape sealer.
5. Seal end of zee closure to panel seams with urethane sealant.
7. Install vented metal to outside closures with Fastener #4 at 6" o.c.
8. Attach ridge flash with Fastener #4 at 6" o.c. to vented metal.
9. Metal vent material must have urethane sealant at all lap conditions.

Ridge With Metal Vent

1. Do not use this detail with the fixed eave or valley details.
2. Field cut zee closures to fit panel width.
3. Install Tri-Bead tape sealer to panels. Center of tape sealer should be 1½" from end of panel.
4. Install zee closures to panels with Fastener #13A at 6" o.c. Vertical leg of zee closure should be 2" from end of panel. Fasteners must go through tape sealer.
5. Seal end of zee closure to panel seams with urethane sealant.
7. Install vented metal to outside closures with Fastener #4 at 6" o.c.
8. Attach ridge flash with Fastener #4 at 6" o.c. to vented metal.
9. Balance vent exhaust at ridge with vent intake at eave or soffit. Metal vent material must have urethane sealant at all trim lap conditions.

DETAILS

FLOATING VALLEY OVER WOOD DECK

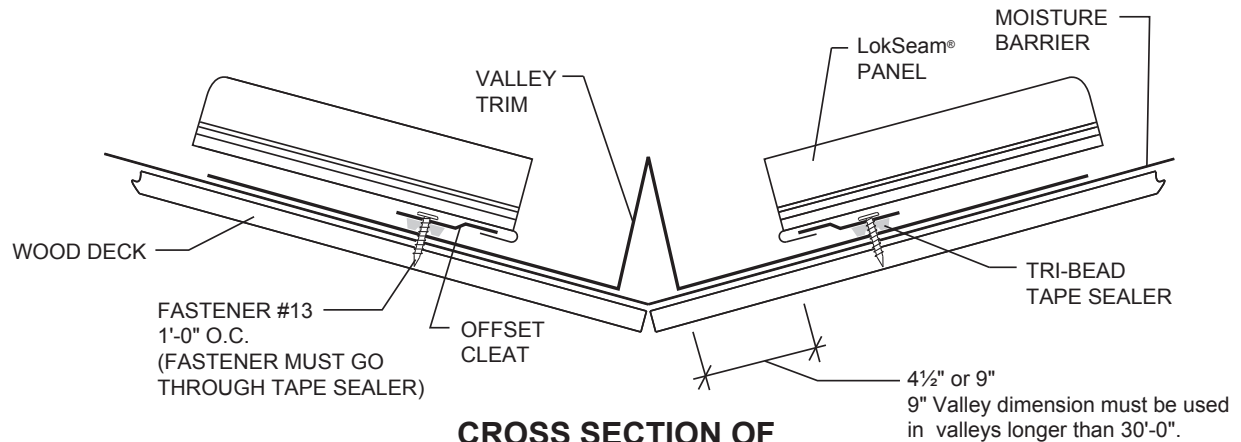

**CROSS SECTION OF
VALLEY OVER WOOD DECK**

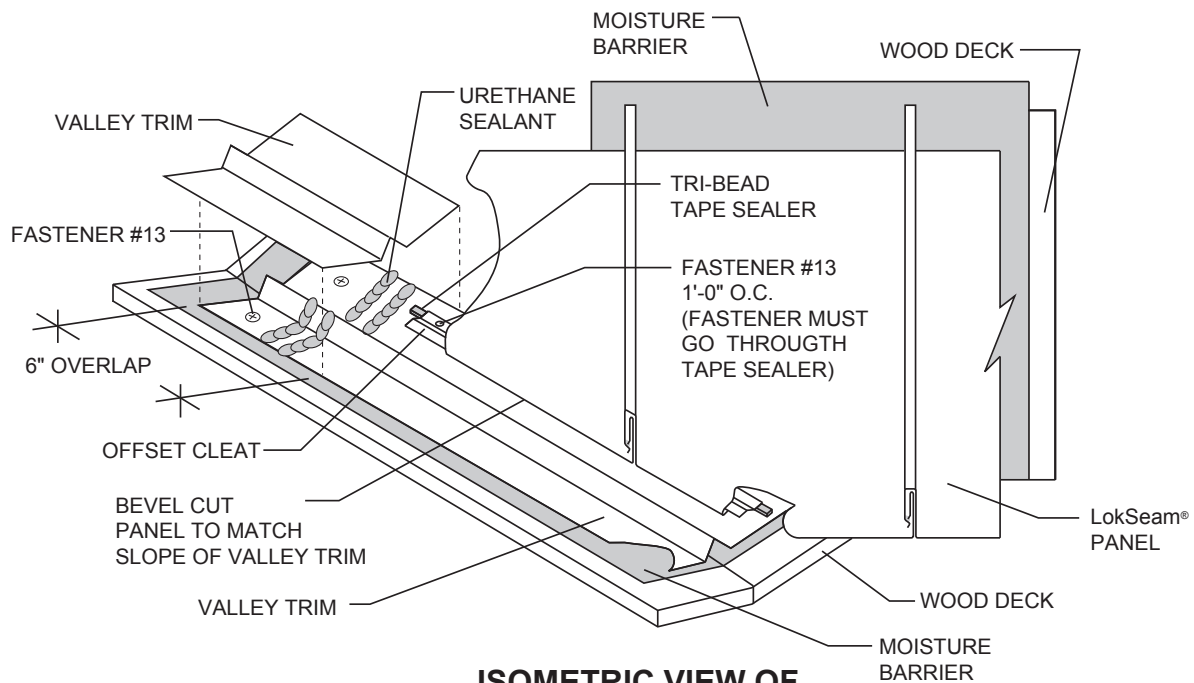

**ISOMETRIC VIEW OF
VALLEY OVER WOOD DECK**

NOTES:

1. For valleys longer than 30', use extended valley trim (see page LS-22).
2. **Panels must be attached to substructure at the ridge or hip to prevent them from sliding downslope.**
3. Offset cleat is installed continuous along slope of valley over Tri-Bead tape sealer with Fastener #13A at 1'-0" o.c. **FASTENERS MUST GO THROUGH TAPE SEALER.**
4. Add 1 1/2" to the panel length for panel hem.
5. See "Panel End Sealant Detail" on page LS-36 to seal panel ends at valley.

DETAILS

FIXED VALLEY OVER WOOD DECK

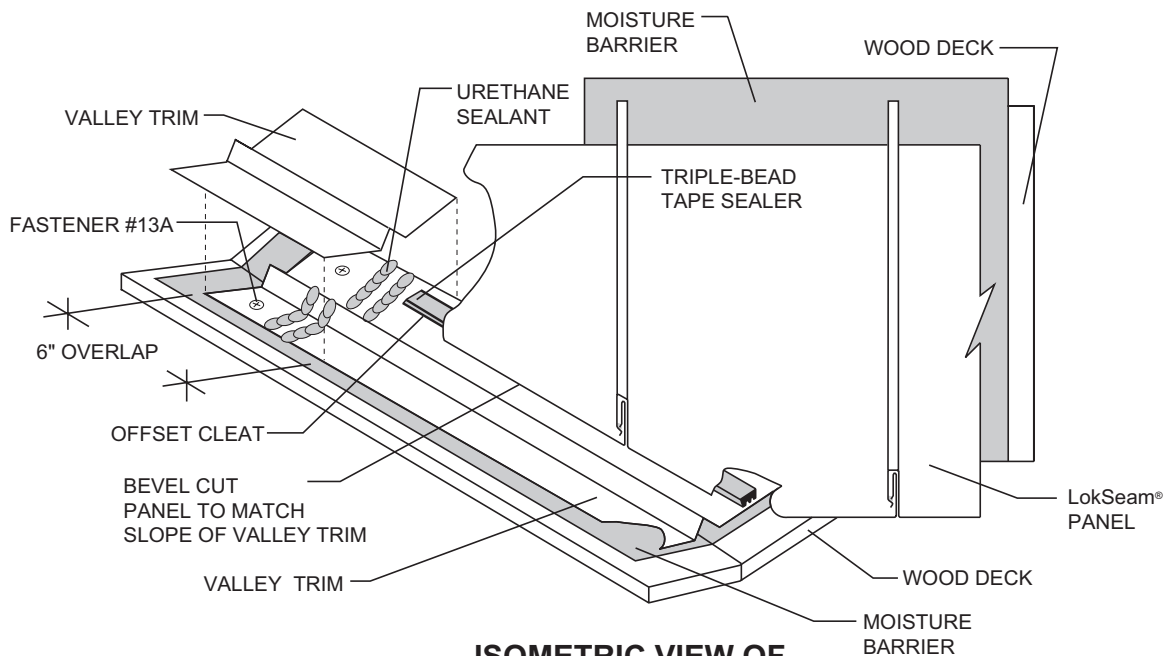
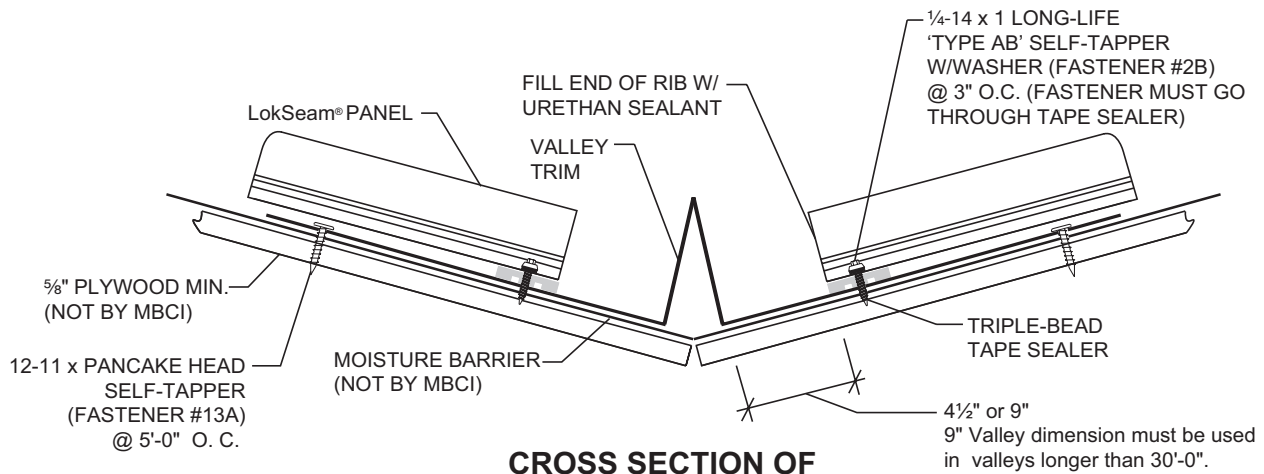

NOTES:

1. For valleys longer than 30', use extended valley trim (see page LS-22).
2. **Do not use this detail with fixed ridge or hip details.**
3. Apply Triple-Bead tape sealer continuously under LokSeam® panel.
4. Attach panels to wood deck with Fastener #2B at 3" on center.
5. See "Panel End Sealant Detail" on page LS-36 to seal panel ends at valley.

DETAILS

HIGH EAVE OVER WOOD DECK

IMPORTANT NOTE:
TEMPORARILY SECURE
PANELS AT PEAK UNTIL
ZEE CLOSURE IS
INSTALLED.

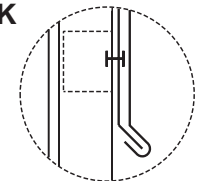
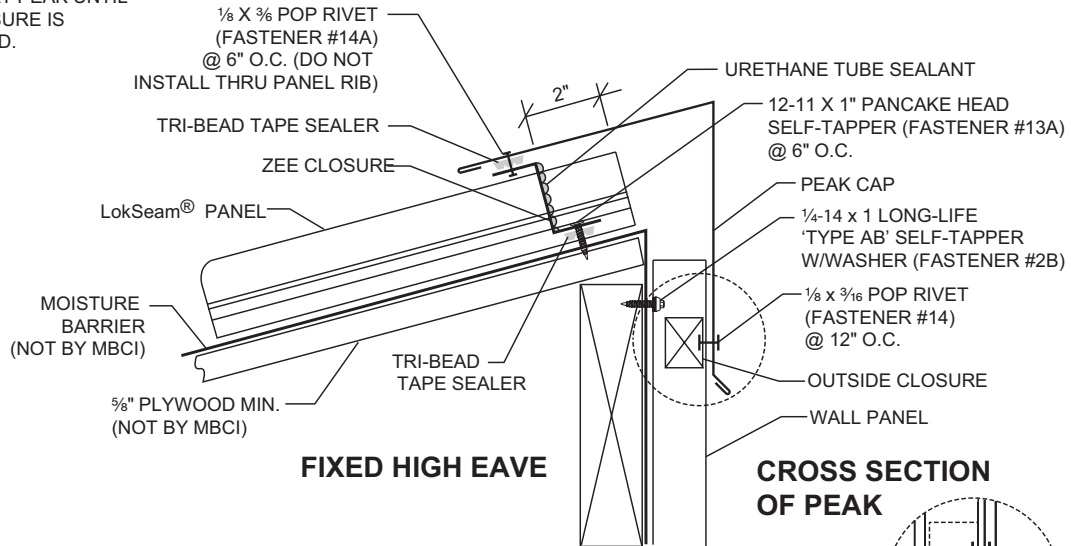

**CONTINUOUS
CLEAT**

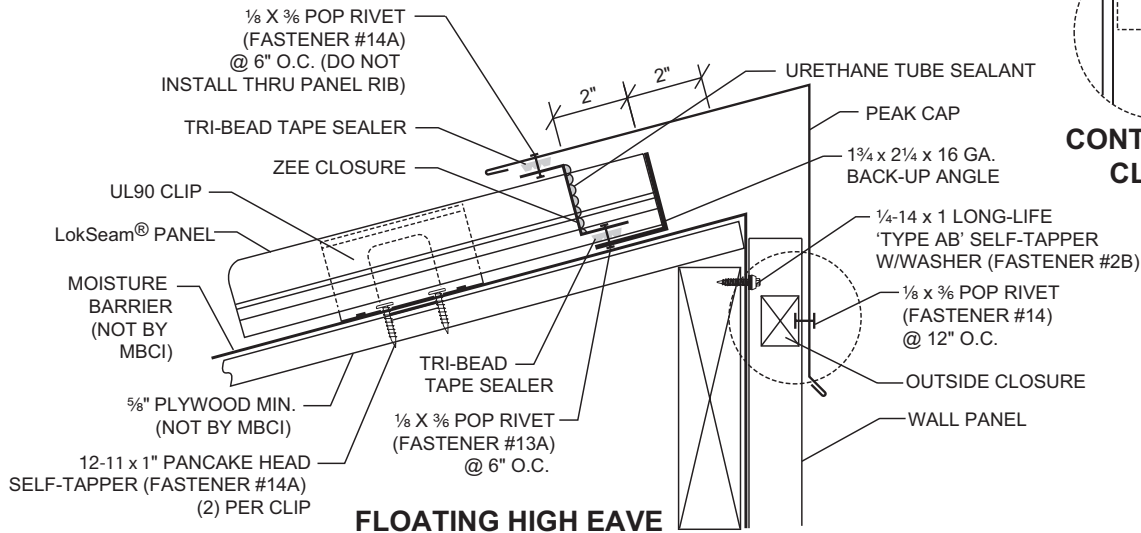

NOTES:

Fixed High Eave

1. Do not use this detail with fixed eave or valley details.
2. Field cut zee closures to fit panel width.
3. Apply Tri-Bead tape sealer to panels. The center of tape sealer should be 1 1/2" from the end of the panel.
4. Install zee closures to panels with Fastener #13A at 6" o.c. Vertical leg of zee closure should be 2" from end of panel.
5. Seal ends of zee closures to panel seams with urethane sealant. Install Tri-Bead tape sealer to top leg of zee closure.
6. Attach peak cap to zee closure with Fastener #14A at 6" o.c.

Floating High Eave

1. Do not use this detail with floating eave or valley details.
2. Field cut zee closures to fit panel width.
3. Apply Tri-Bead tape sealer to panels. The center of tape sealer should be 1 1/2" from the end of the panel.
4. Install zee closures to panels with Fastener #13A at 6" o.c. Vertical leg of zee closure should be 2" from end of panel.
5. Seal ends of zee closures to panel seams with urethane sealant. Install Tri-Bead tape sealer to top leg of zee closure.
6. Attach peak cap to zee closure with Fastener #14A at 6" o.c.

DETAILS

FLOATING EAVE WITH EAVE TRIM OVER WOOD DECK

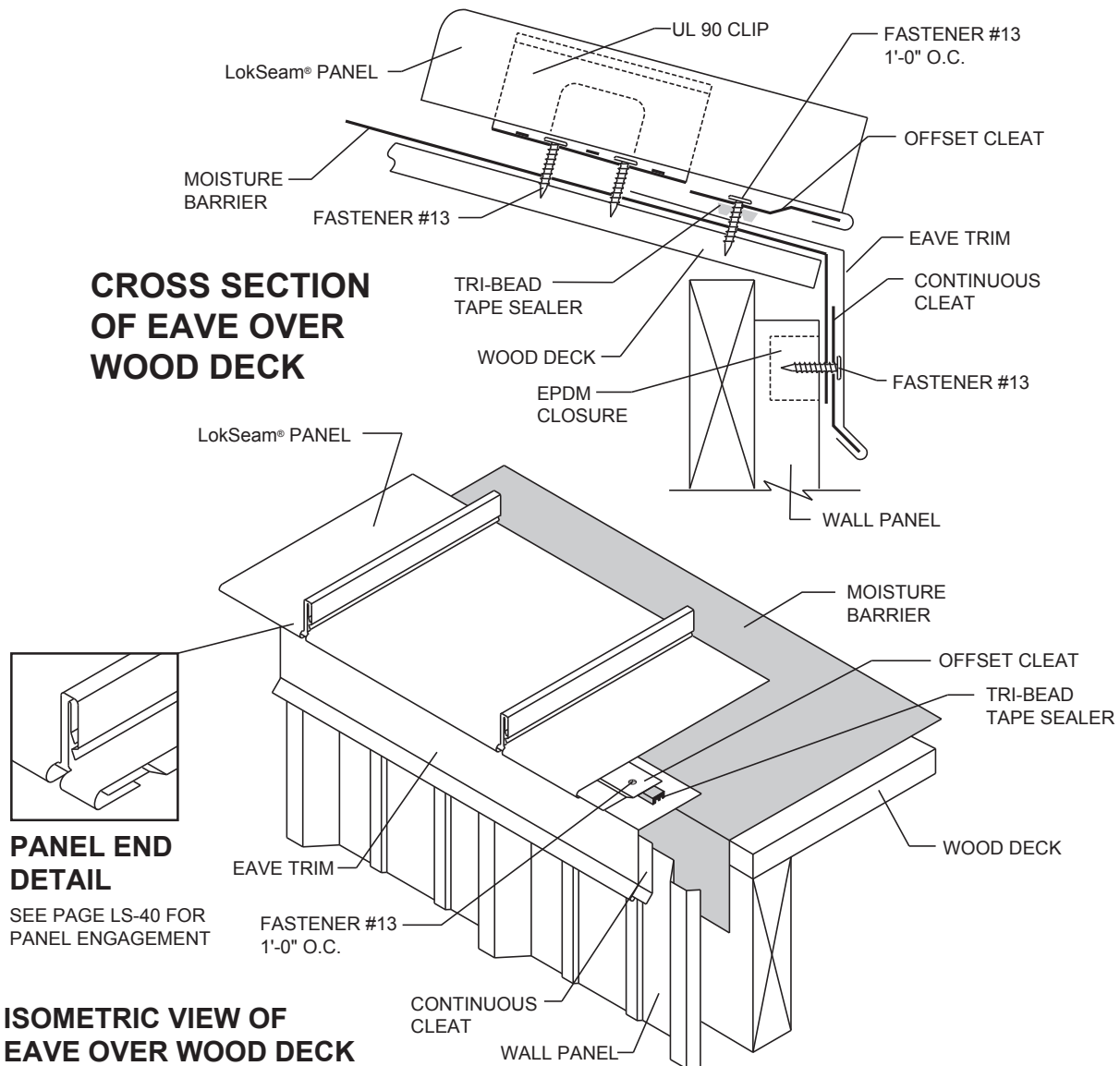

**CROSS SECTION
OF EAVE OVER
WOOD DECK**

**PANEL END
DETAIL**

SEE PAGE LS-40 FOR
PANEL ENGAGEMENT

**ISOMETRIC VIEW OF
EAVE OVER WOOD DECK**

NOTES:

Eave with Offset Cleat

1. Panels must be attached to substructure at the ridge, high eave, endlap or hip to prevent them from sliding downslope.
2. Offset cleat is installed continuous along eave over Tri-Bead tape sealer with Fastener #13A at 1'-0" o.c.
FASTENERS MUST GO THROUGH TAPE SEALER.
3. Clip spacing should not exceed 4'-0" o.c. for 24-gauge panels or 5'-0" o.c. for 22-gauge panels.
4. Add 1½" to the panel length for the panel hem.
5. See "Panel End Sealant Detail" on page LS-36 to seal panel ends at valley.

Eave with Extended Drip Edge

1. Panels must be attached to substructure at the ridge, high eave, endlap or hip to prevent them from sliding downslope.
2. Attach eave trim to the wood deck with Fastener #13A at 2'-0" o.c.
FASTENERS MUST GO THROUGH TAPE SEALER.
3. To field hem panel, see page LS-35.
4. See "Panel End Sealant Detail" on page LS-36.

DETAILS

FIXED EAVE WITH EAVE TRIM OVER WOOD DECK

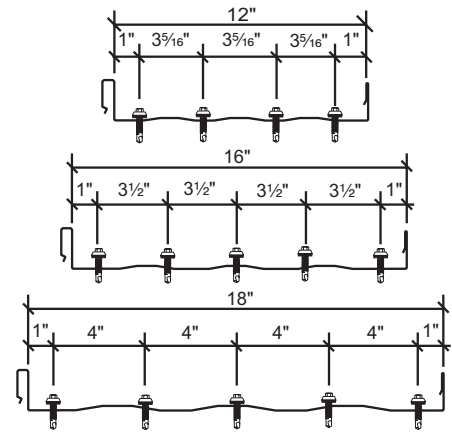

FASTENER SPACING @ EAVE

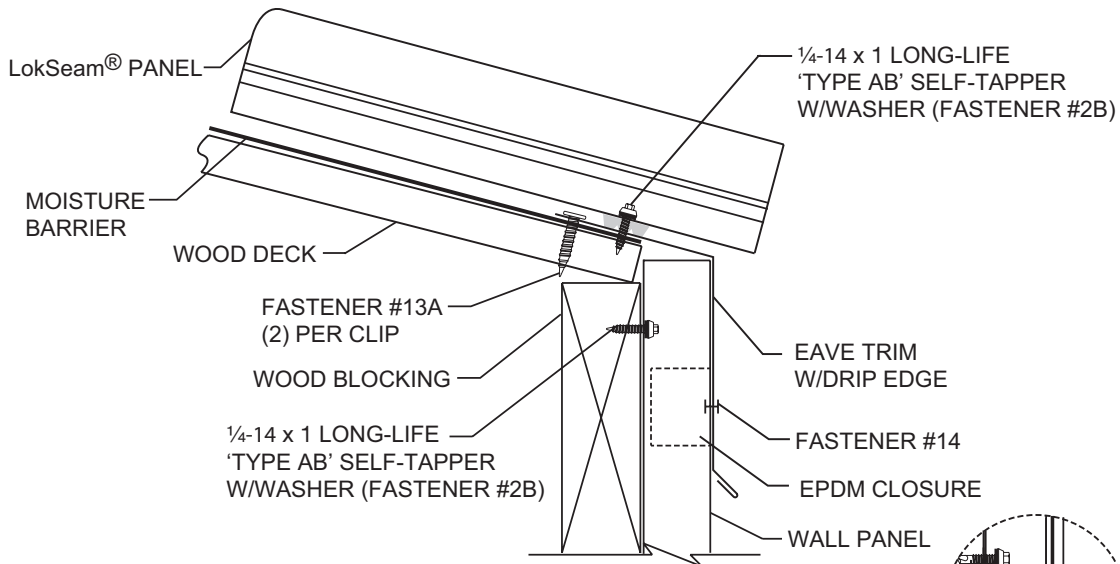

PANEL END DETAIL

FILL END OF RIB WITH
URETHANE SEALANT

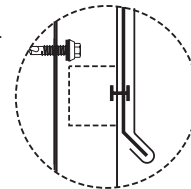
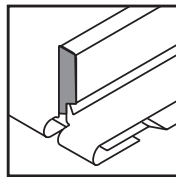

OPTIONAL CONTINUOUS CLEAT

NOTES:

1. Do not use this detail with the fixed ridge or hip details.
2. Attach eave trim to wood deck with Fastener #13A (3 fasteners per 10' piece).
3. Apply Tri-Bead tape sealer to slope leg of eave trim. Edge of tape sealer should align with edge of wood deck.
4. Install panel and fasten to wood deck with Fastener #2B.
5. See "Panel End Sealant Detail" on page LS-36 to seal panel ends.

DETAILS

FLOATING EAVE WITH GUTTER OVER WOOD DECK

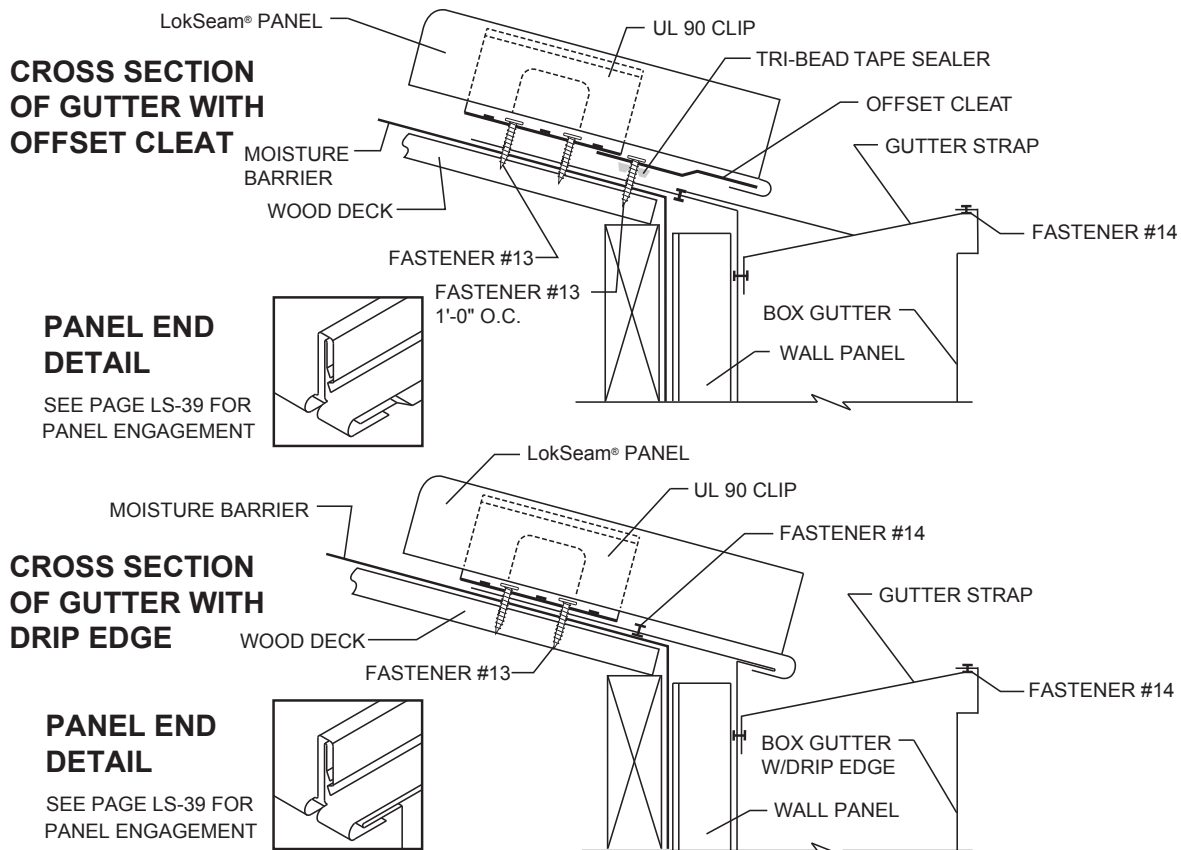

NOTES:

Offset Cleat

1. The offset cleat method of attachment should be used when ridge, peak or endlap is fixed to the substructure. Panels must be attached at one of these points to prevent them from sliding downslope.
2. Attach offset cleat to wood deck with Fastener #13A at 1'-0" o.c.
3. To field hem panel, see page LS-35
4. See "Panel End Sealant Detail" on page LS-36 to seal panel ends.
5. The above gutter should not be used in areas that experience snow loads of 10 PSF or higher. See page LS-48 for the gutter detail for these areas.

Gutter with Drip Edge

1. The gutter with drip edge method of attachment should be used when ridge, high eave or endlap is fixed to the substructure. Panels must be attached at one of these points to prevent them from sliding downslope.
2. Install gutter to wood deck with Fastener #13A at 2'-0" o.c.
3. Attach gutter straps to gutter with Fastener #14 at 3'-0" o.c.
4. To field hem panel, see page LS-35.
5. Notch panel hem for gutter strap.
6. See "Panel End Sealant Detail" on page LS-36 to seal panel ends.
7. This detail may be used on roofs with pitches of 3:12 or greater. For roofs with pitches less than 3:12, call MBCI.
8. The above gutter should not be used in areas that experience snow loads of 10 PSF or higher. See page LS-48 for the gutter detail for these areas.

DETAILS

FIXED EAVE WITH GUTTER OVER WOOD DECK

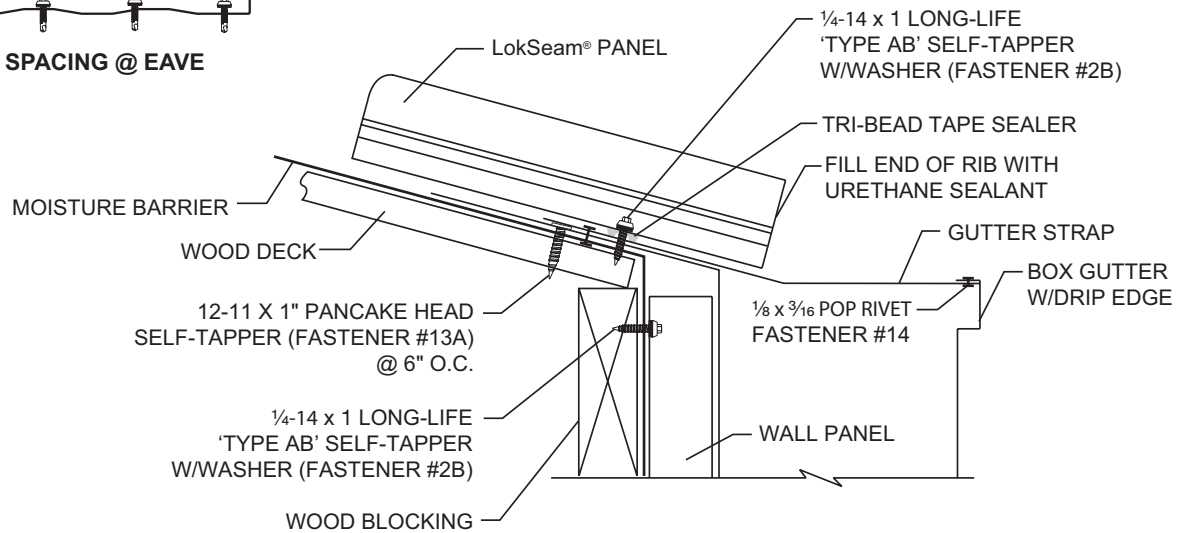
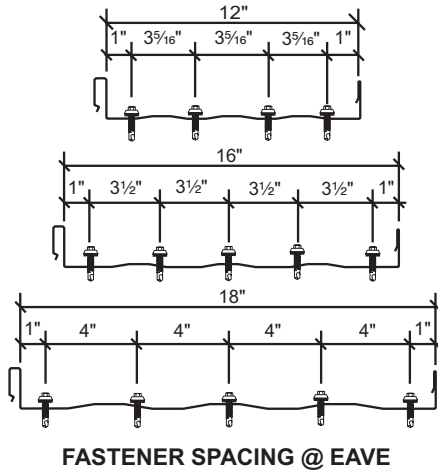

PANEL END DETAIL

FILL END OF RIB WITH
URETHANE SEALANT

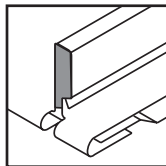

NOTES:

Fixed Eave with Gutter

1. Do not use this detail with the fixed ridge or hip details.
2. Attach gutter to wood deck with Fastener #13A (3 fasteners per 10' piece)
3. Install gutter straps every 3'-0" of gutter length. Attach to outside leg of gutter and slope leg of gutter with Fastener #14.
4. Apply Tri-Bead tape sealer to slope leg of gutter. Edge of tape sealer should align with edge of wood deck.
5. Install panel and fasten to wood deck with fastener #2B at the spacing shown in the above diagram.
6. See "Panel End Sealant Detail" on page LS-36 to seal panel ends.
7. The above gutter should not be used in areas that experience snow loads of 10 PSF or greater.

DETAILS

FLOATING RAKE OVER WOOD DECK

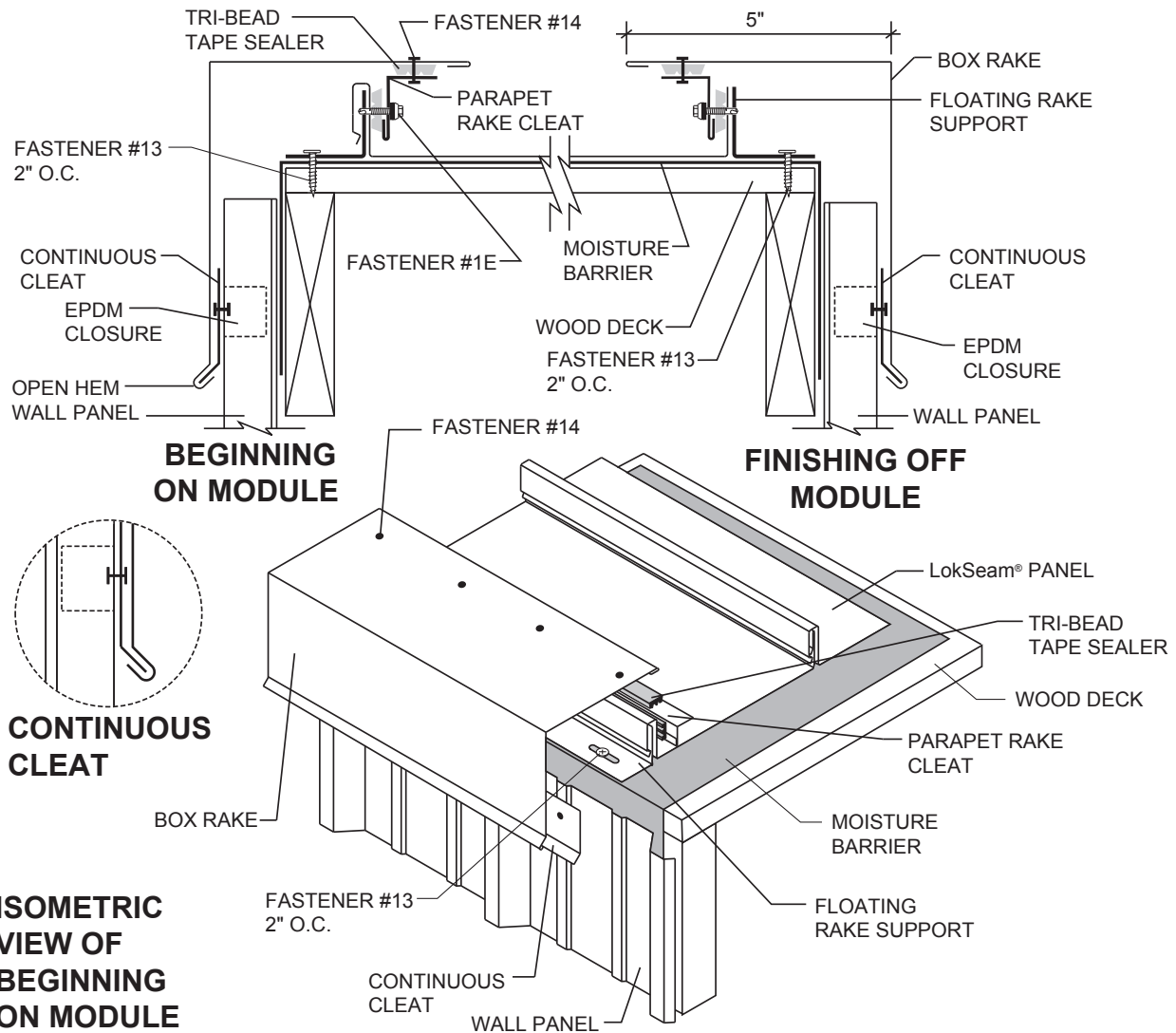

NOTES:

1. The top dimension of the rake will be affected by the wall panel thickness.
2. Install floating rake support with Fastener #13A at 2'-0" o.c. (Install Fastener #13A so as not to restrict the movement of the rake support).
3. Engage female leg of panel over rake support.
4. Apply Tri-Bead tape sealer to vertical leg of panel. Install parapet rake cleat to panel leg with Fastener #1E at 2'-0" o.c. **FASTENERS MUST GO THROUGH RAKE SUPPORT.**
5. Apply Tri-Bead tape sealer to top of parapet rake cleat and attach rake trim to parapet rake cleat with Fastener #14A at 6" o.c.
6. Use continuous cleat to hold bottom of rake trim in place. Fasten continuous cleat to each high rib of wall panel. The bottom hem of the rake trim is "open".
7. If roof finishes on module, finishing detail will be similar to starting detail. If roof finishes off module, field cut and bend last panel run to fit against floating rake support. Install parapet rake cleat, tape sealer and rake trim as previously described.
8. If rake trim is not to be immediately installed, temporarily fasten panels to rake support to prevent wind damage.

DETAILS

FIXED RAKE OVER WOOD DECK

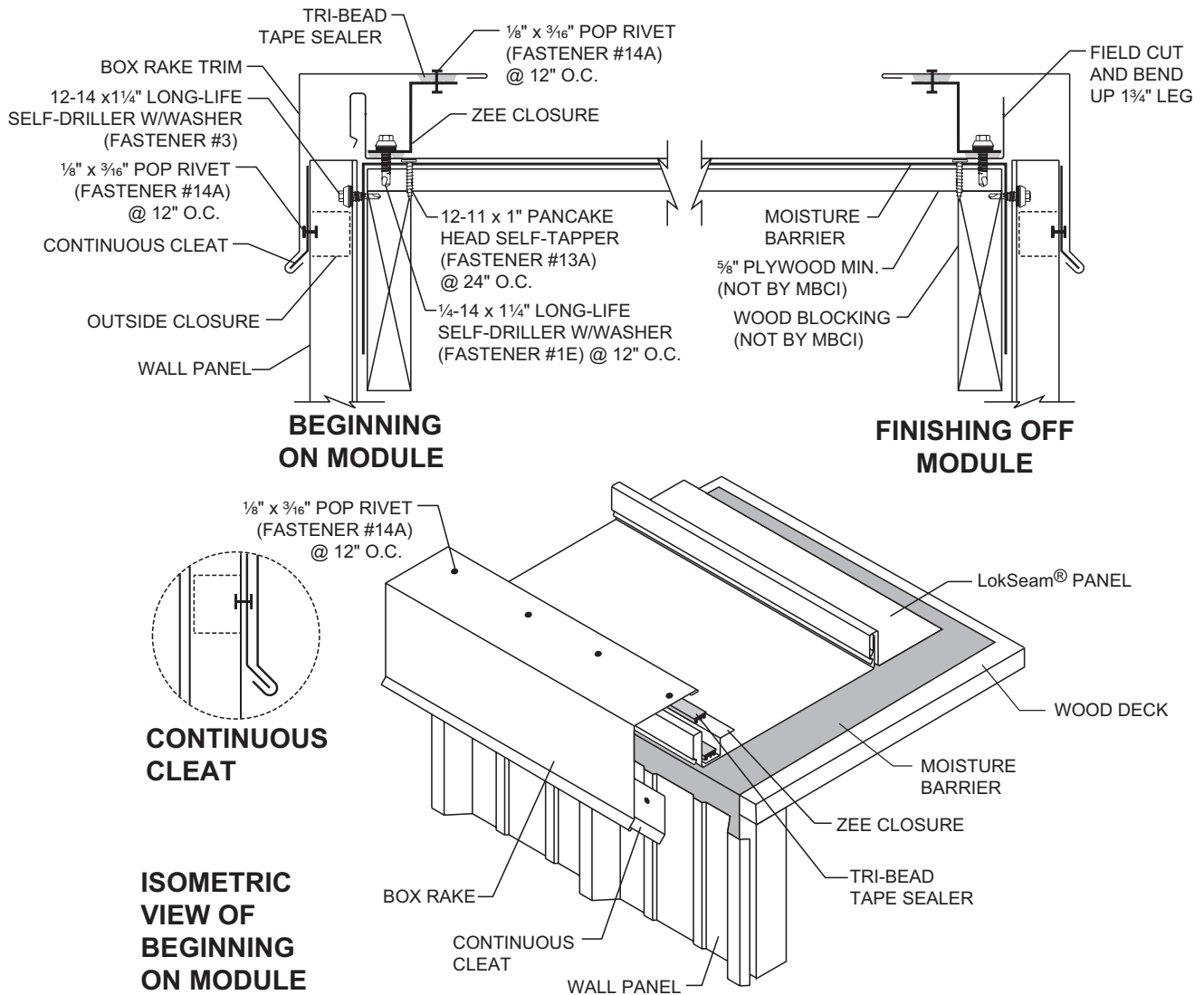

NOTES:

1. Apply Tri-Bead tape sealer to bottom leg of zee closure.
2. Install zee closure to panel with Fastener #13A at 12" on center.
3. Apply Tri-Bead tape sealer to top leg of zee closure and attach rake trim to zee closure with Fastener #14A at 12" on center.
4. If roof finishes on module, finishing detail will be similar to starting detail. If roof finishes off module, field cut panel and bend a 1 1/4" leg before installing zee closure.

DETAILS

FIXED PARAPET HIGH EAVE OVER WOOD DECK

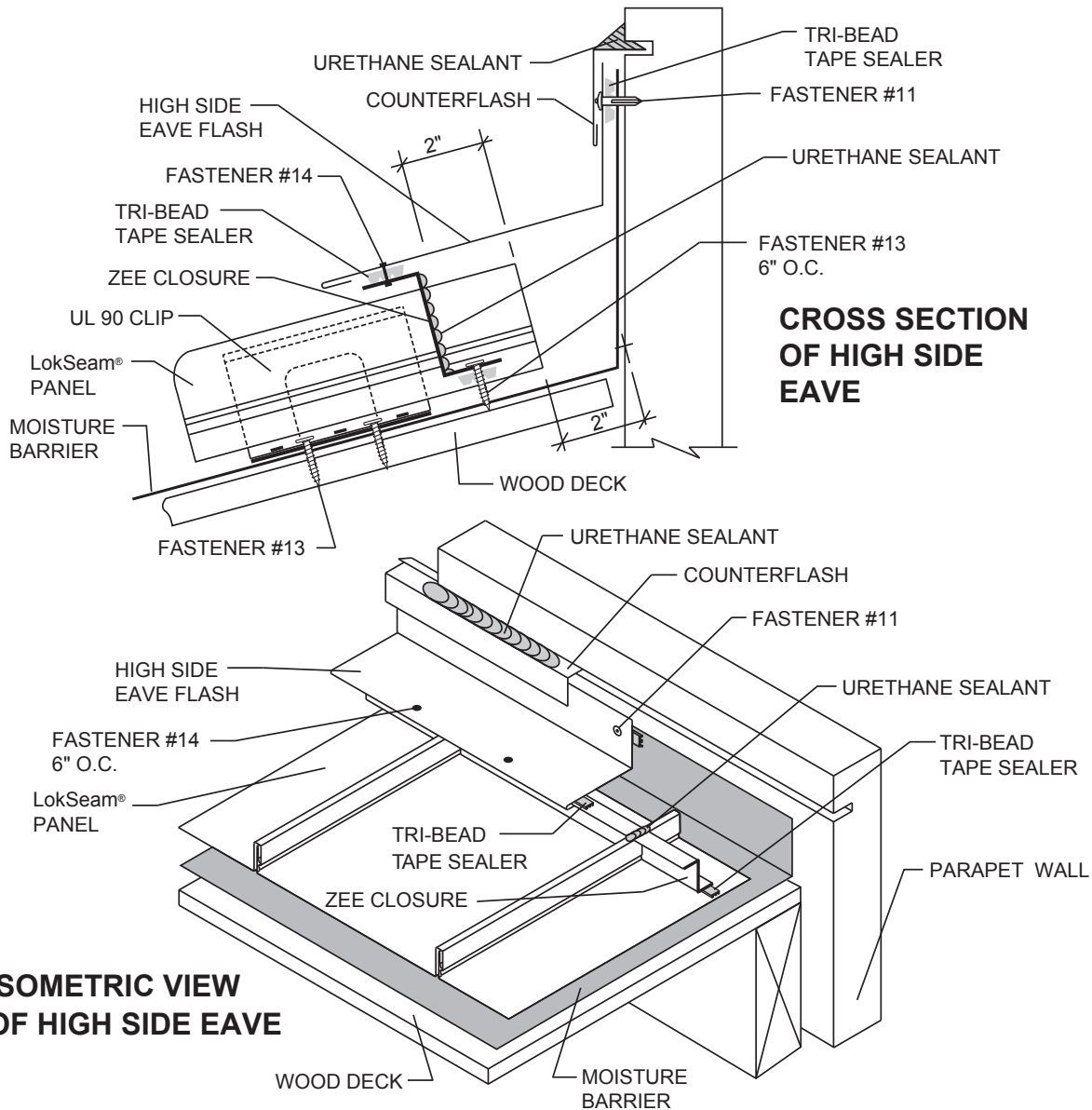

NOTES:

1. Do not use this detail with fixed eave or valley details.
2. Field cut zee closures to fit panel width.
3. Apply Tri-Bead tape sealer to panels. Center of tape sealer should be 1½" from end of panel.
4. Install zee closures to panels with Fastener #13A at 6" o.c. Vertical leg of zee closures should be 2" from end of panels.
5. Seal ends of zee closures to the panel seams with urethane sealant. Apply Tri-Bead tape sealer to the top leg of zee closures.
6. Attach parapet high side eave trim to zee closure with Fastener #4 at 6" o.c.
7. Seal counterflash to parapet wall with urethane sealant.

DETAILS

FLOATING PARAPET HIGH EAVE OVER WOOD DECK

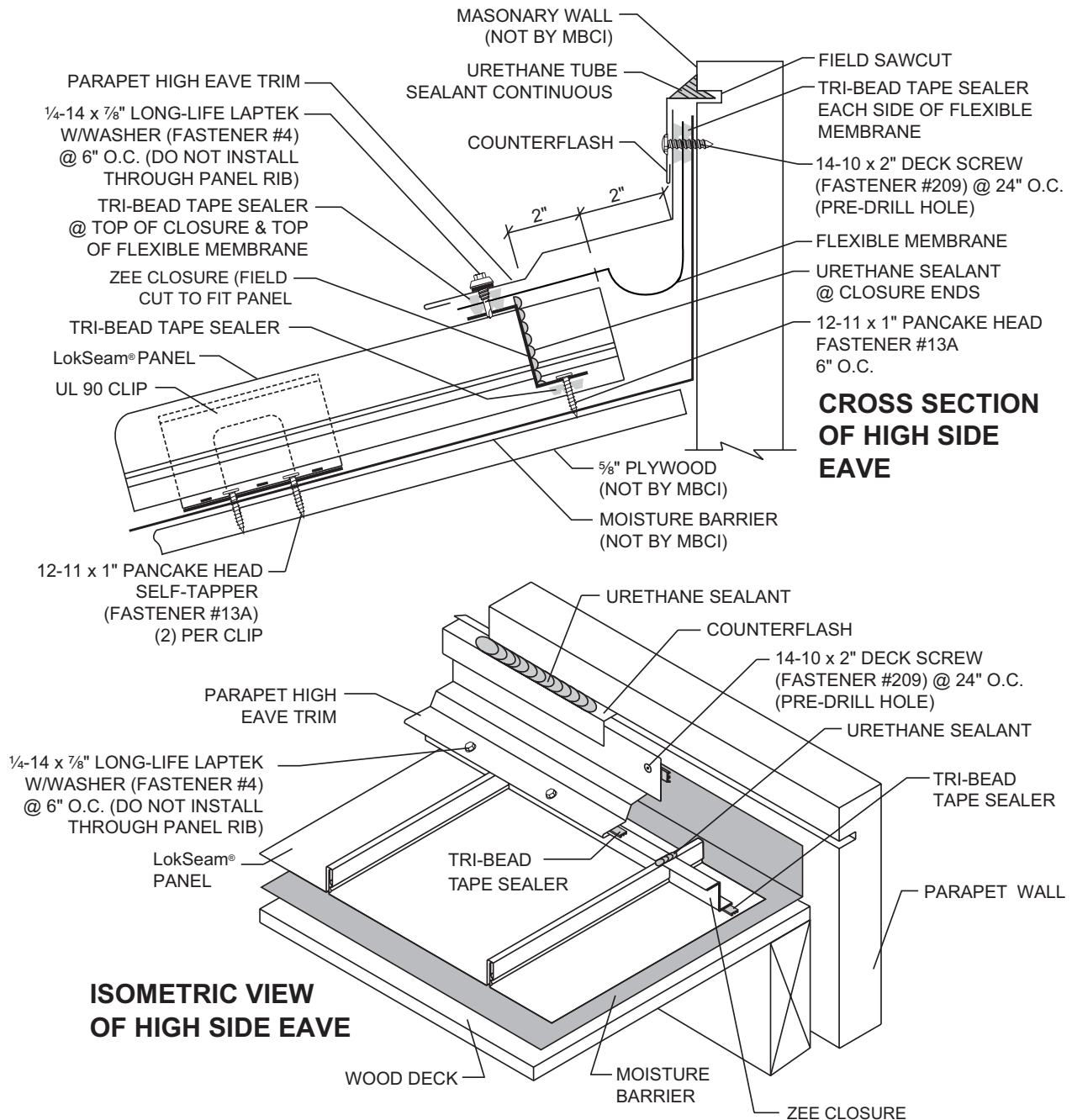

NOTES:

1. Do not use this detail with fixed eave or valley details.
2. Field cut zee closures to fit panel width.
3. Apply Tri-Bead tape sealer to panels. Center of tape sealer should be 1½" from end of panel.
4. Install zee closures to panels with Fastener #13A at 6" o.c. Vertical leg of zee closures should be 2" from end of panels.
5. Seal ends of zee closures to the panel seams with urethane sealant. Apply Tri-Bead tape sealer to the top leg of zee closures.
6. Attach parapet high side eave trim to zee closure with Fastener #4 at 6" o.c.
7. Seal counterflash to parapet wall with urethane sealant.

DETAILS

FLOATING PARAPET RAKE OVER WOOD DECK

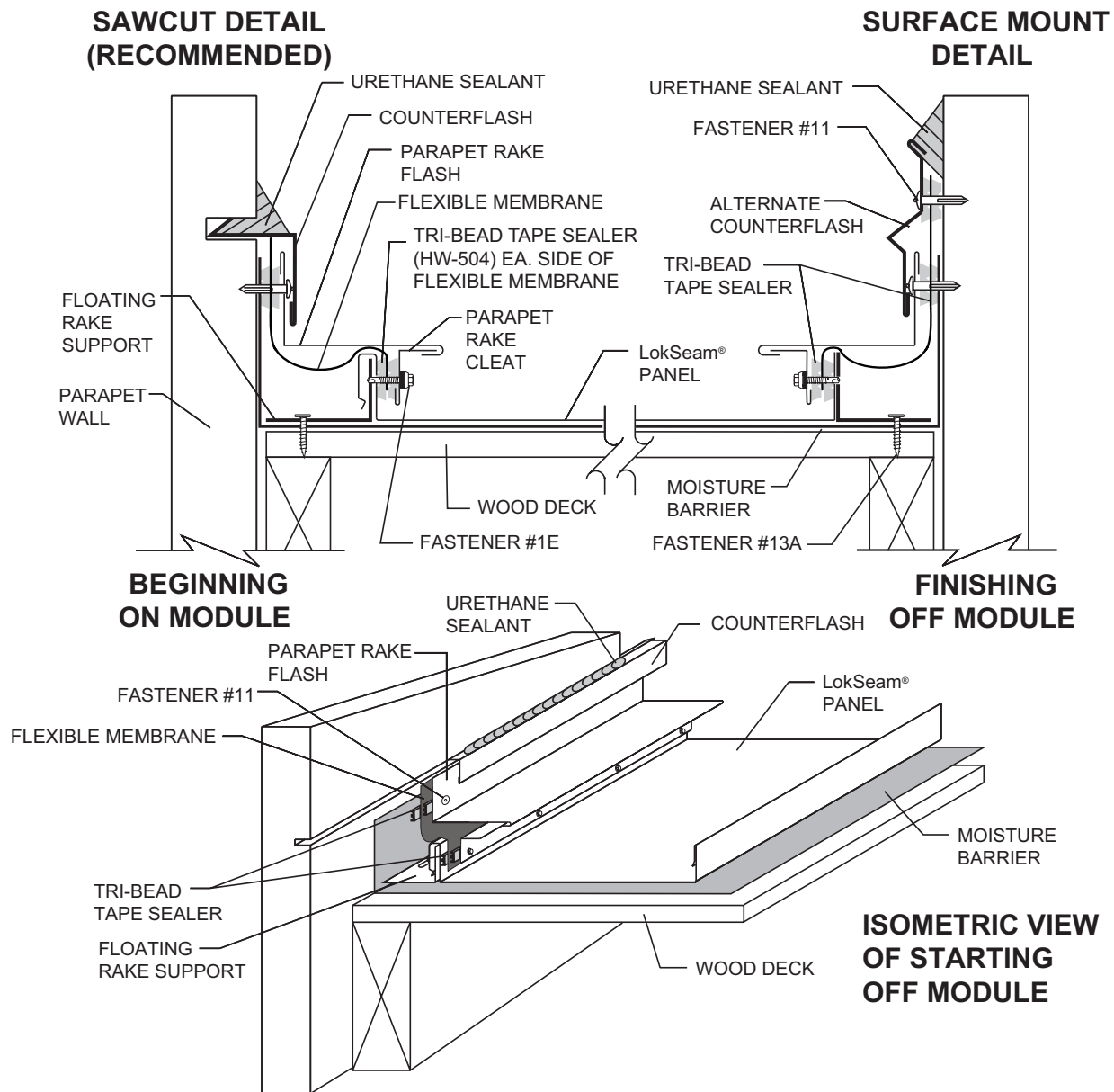

NOTES:

1. Install floating rake support with Fastener #13A at 2'-0" o.c. (Install Fastener #13A so as not to restrict the movement of the rake support).
2. Engage female leg of panel over rake support.
3. Apply Tri-Bead tape sealer to vertical leg of panel. Install flexible membrane and parapet rake cleat to panel leg with Fastener #1E at 2'-0" o.c.
FASTENERS MUST GO THROUGH RAKE SUPPORT.
4. Engage open hem of parapet rake flash onto parapet rake cleat and fasten top leg to parapet wall with Fastener #11.
5. If roof finishes on module, finishing detail will be similar to starting detail. If roof finishes off module, field cut and bend last panel run to fit against floating rake support. Install parapet rake cleat, tape sealer and parapet rake flash as previously described.
6. If parapet rake flash is not to be immediately installed, temporarily fasten panels to rake support to prevent wind damage.

DETAILS

FIXED PARAPET RAKE OVER WOOD DECK

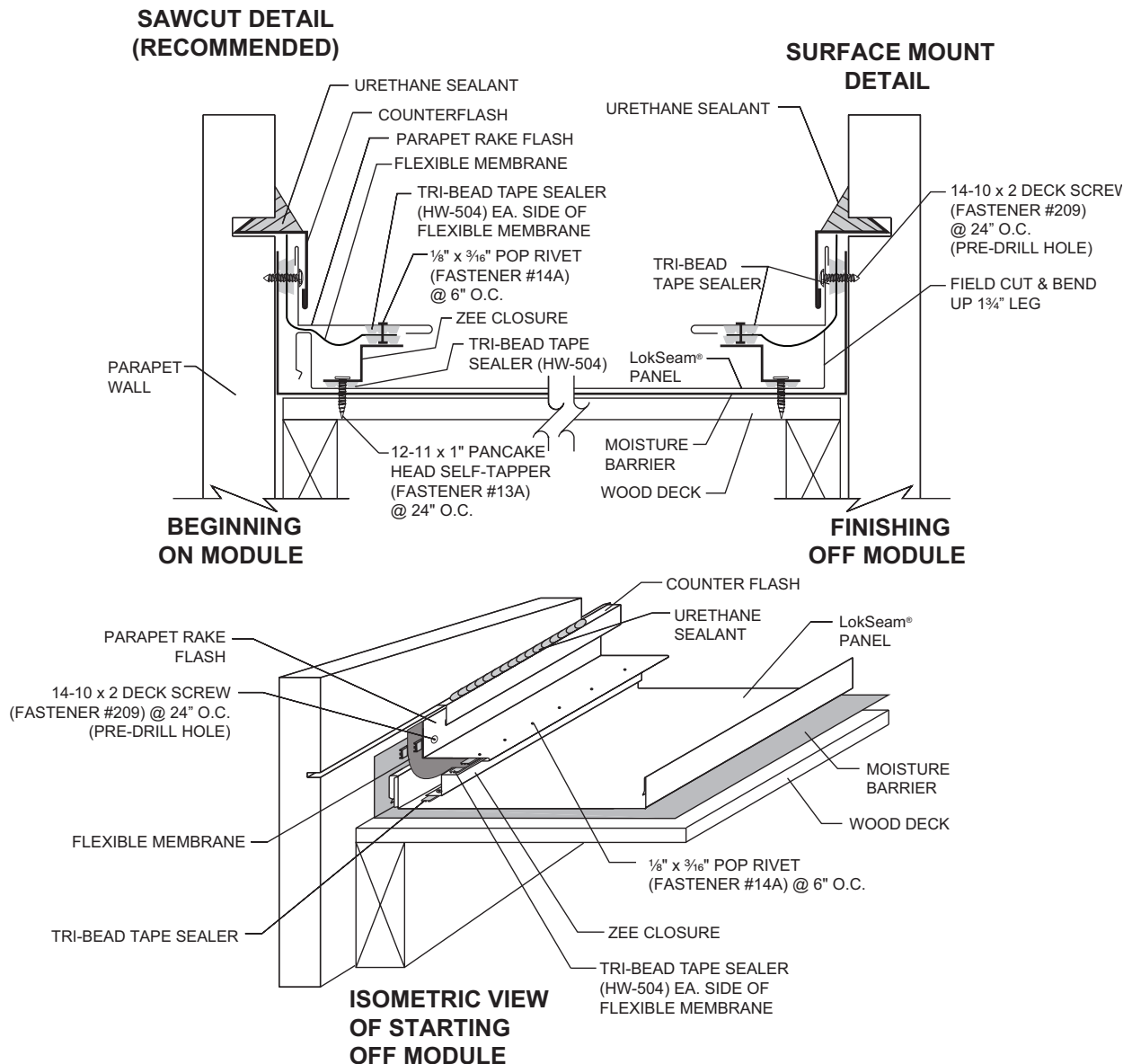

NOTES:

1. Apply Tri-Bead tape sealer to bottom leg of zee closure.
2. Install zee closure to panel with fastener #13A at 12" on center.
3. Apply Tri-Bead tape sealer to top leg of zee closure.
4. Attach flexible membrane to Tri-Bead tape sealer on top of zee closure and add a second run of Tri-Bead tape sealer on top of the flexible membrane.
5. Attach parapet rake trim to zee closure with Fastener #14A at 12" on center.
6. If roof finishes on module, finishing detail will be similar to starting detail. If roof finishes off module, field cut panel and bend a 1 1/4" leg before installing zee closure.

DETAILS

ROOF TRANSITION OVER WOOD DECK

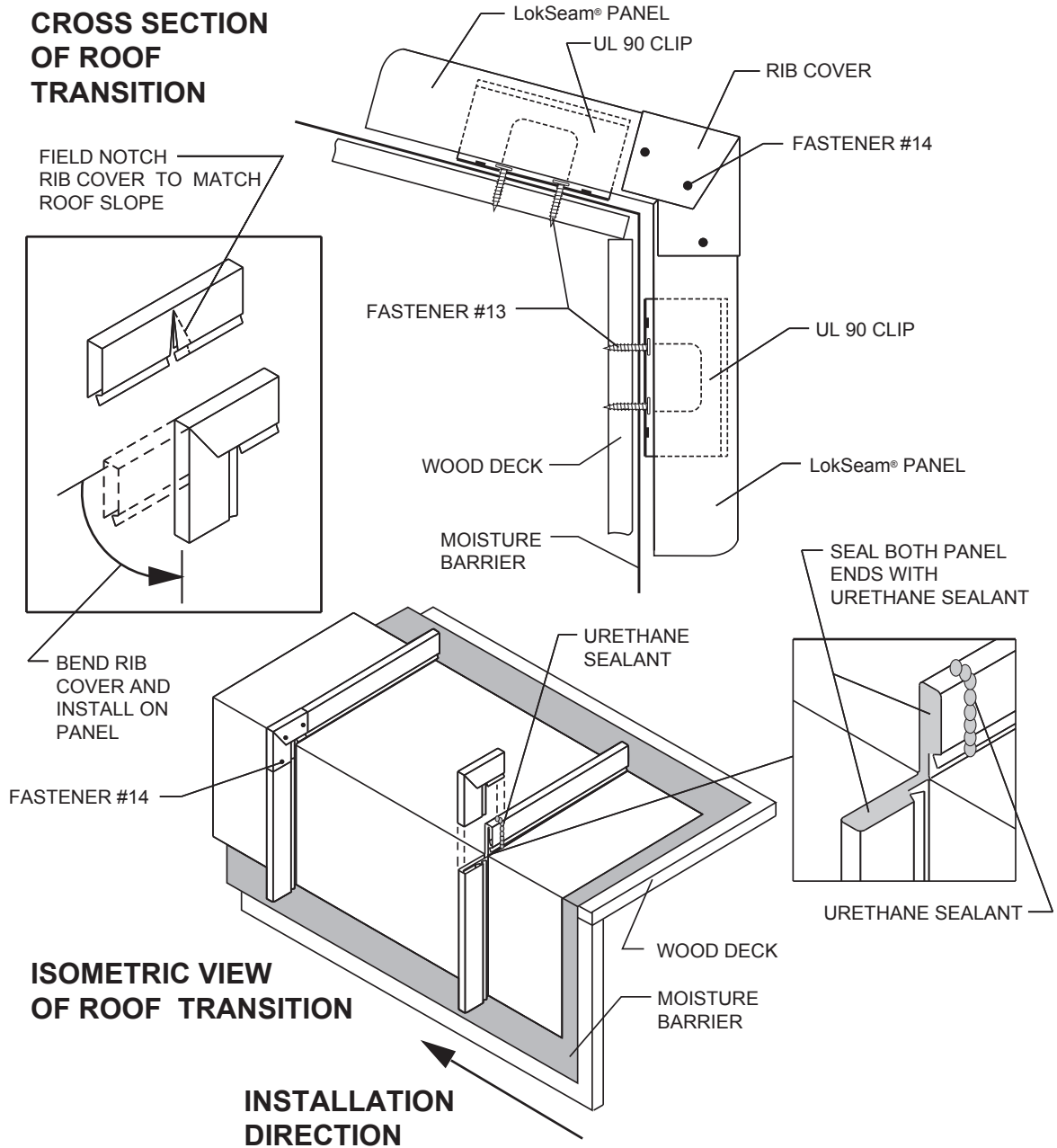

NOTES:

1. Do not use this detail with the fixed ridge or hip details.
2. Field cut legs of panels and bend to required angle.
3. Fill both exposed ends of panel with urethane sealant.
4. Field notch rib cover to allow it to bend to the proper angle.
5. Field apply a bead of urethane sealant over rib before applying rib cover.
6. A moisture barrier must be installed and extended a minimum of 12" up slope and behind the fascia to the bottom.
7. **Do not use this detail inside the building envelope.**

DETAILS

RIGID BOARD INSULATION OVER METAL DECK

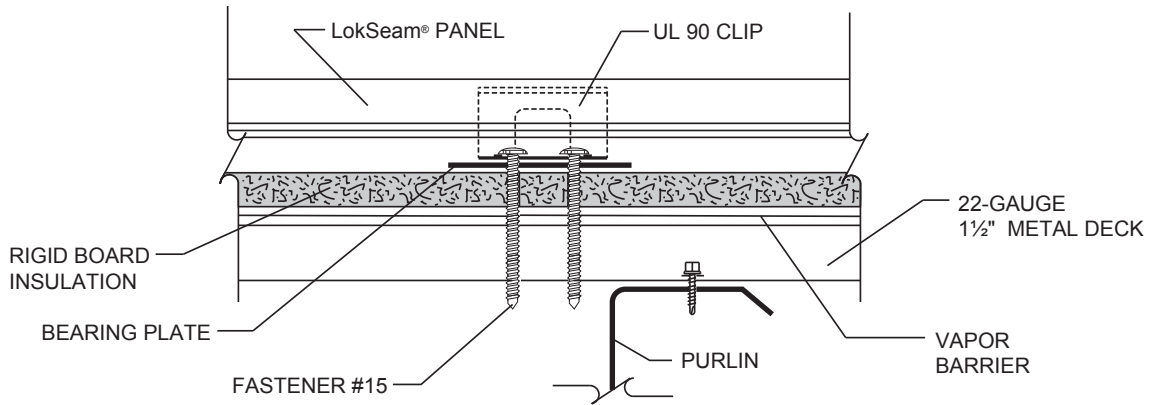

CROSS SECTION OF RIGID BOARD INSULATION OVER METAL DECK

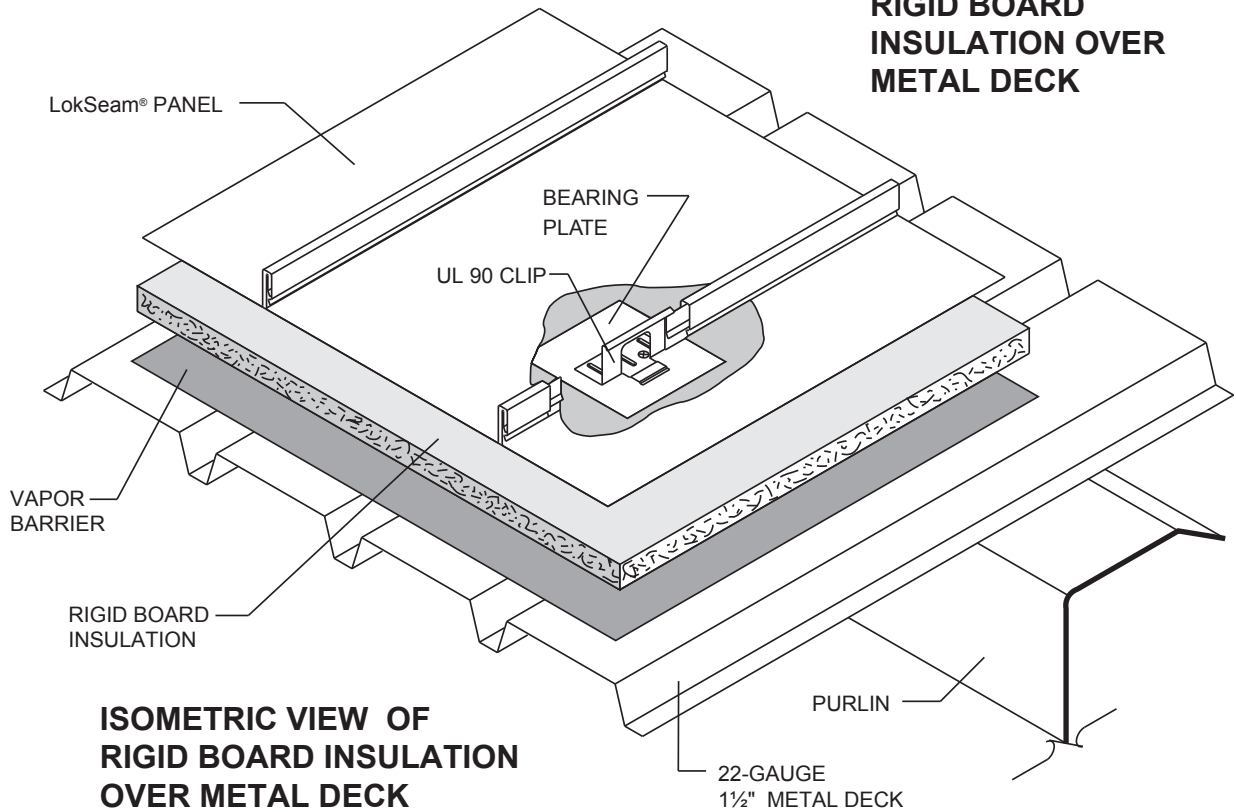

ISOMETRIC VIEW OF RIGID BOARD INSULATION OVER METAL DECK

NOTES:

1. Metal deck to be 1½" deep, 22-gauge.
2. Rigid board insulation to be 1" - 4" thick.
3. Clips and bearing plates to be installed simultaneously with two Deck Fasteners into the metal deck. Length of fasteners to be determined by thickness of insulation plus depth of metal deck. Fasteners should extend ¼" below metal deck.
4. Some composite systems require additional acoustical consideration. Contact your architect and/or engineer for proper acoustical design.

DETAILS

ENDLAP OVER METAL DECK

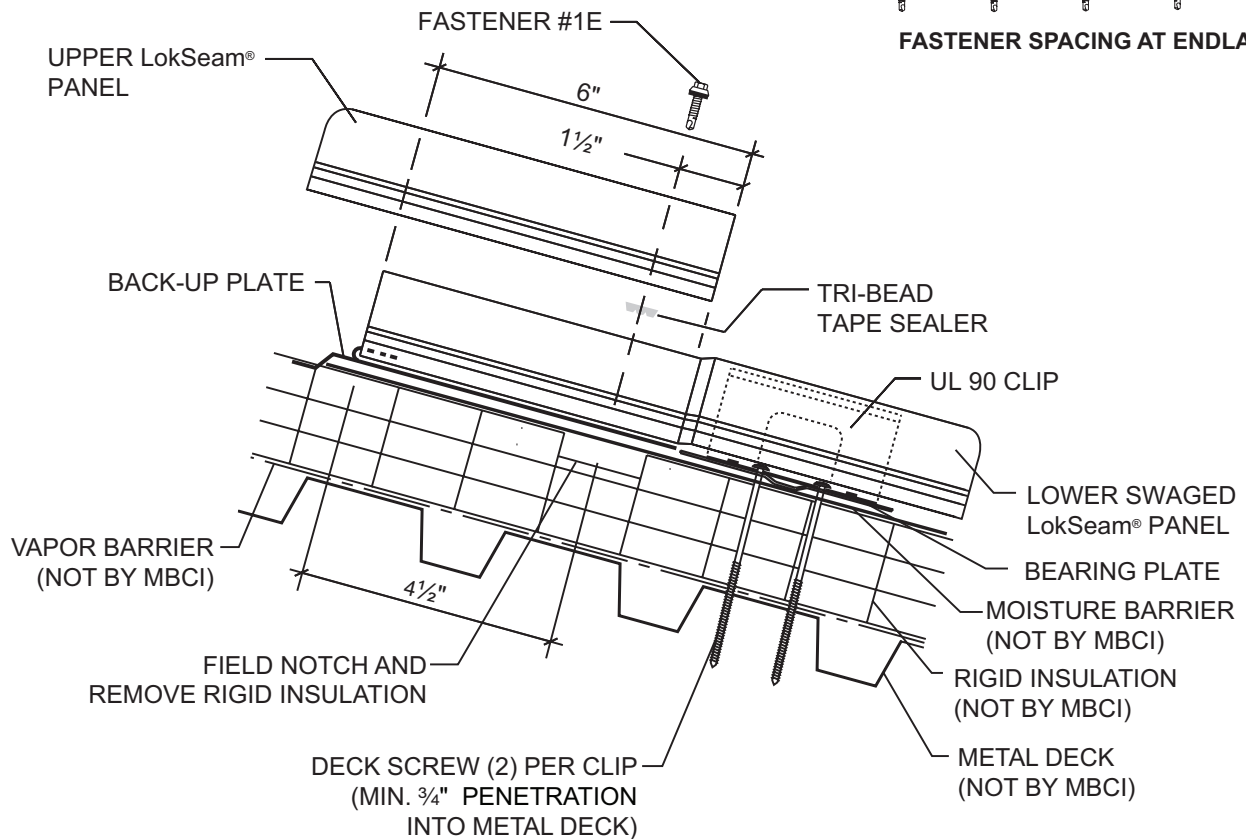
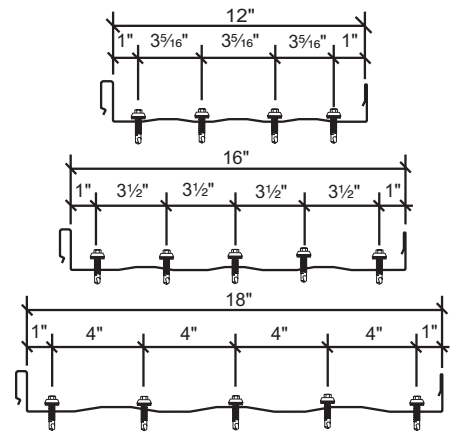

NOTES:

1. Install bottom panel so that the eave has the proper overhang (refer to eave details).
2. Slide a prepunched back-up plate onto the upper end of the panel; make sure the teeth of the back-up plate are on top of the panel. Visually check to see that the holes in the back-up plate align with the prepunched holes in the panel.
3. Place Tri-Bead tape sealer over the entire width of the panel. It must be centered directly over the prepunched holes.
4. Using an awl to align the holes, install top panel by lapping it over the swaged portion of the bottom panel. Install Fastener #1E in the prepunched holes in the proper sequence.
5. Endlaps require roof erection to proceed from left to right as viewed from the eave looking toward the ridge.

DETAILS

FIXED RIDGE OVER METAL DECK

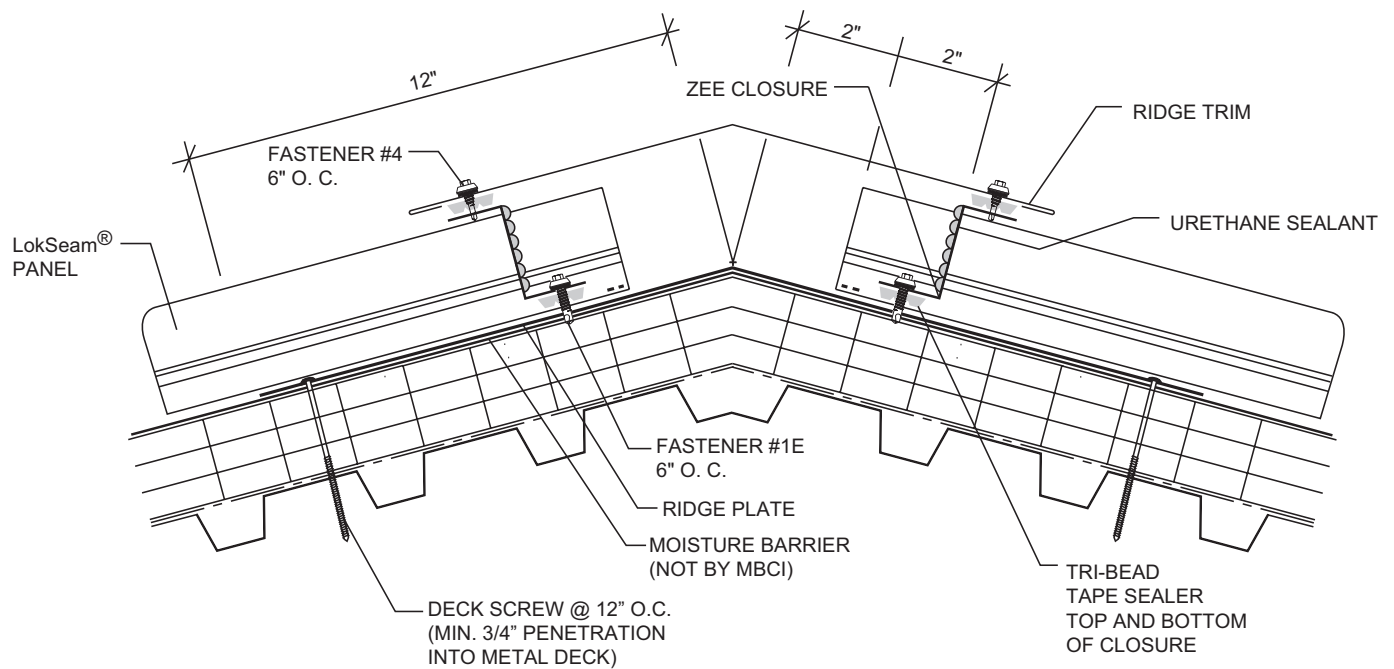

NOTES:

1. Use this detail with a floating eave or valley detail.
2. Field cut zee closures to fit panel width.
3. Install Tri-Bead tape sealer to panels. The center of the tape sealer should be 1½" from end of panel.
4. Install zee closures to panels with Fastener #1E at 6" on center. Vertical leg of zee closure should be 2" from end of panel.
5. Seal end of zee closure to panel seam with urethane sealant. Install Tri-Bead tape sealer to top of zee closures.
6. Attach ridge flash to zee closure with Fastener #4 at 6" on center.

DETAILS

VENTED RIDGE OVER METAL DECK

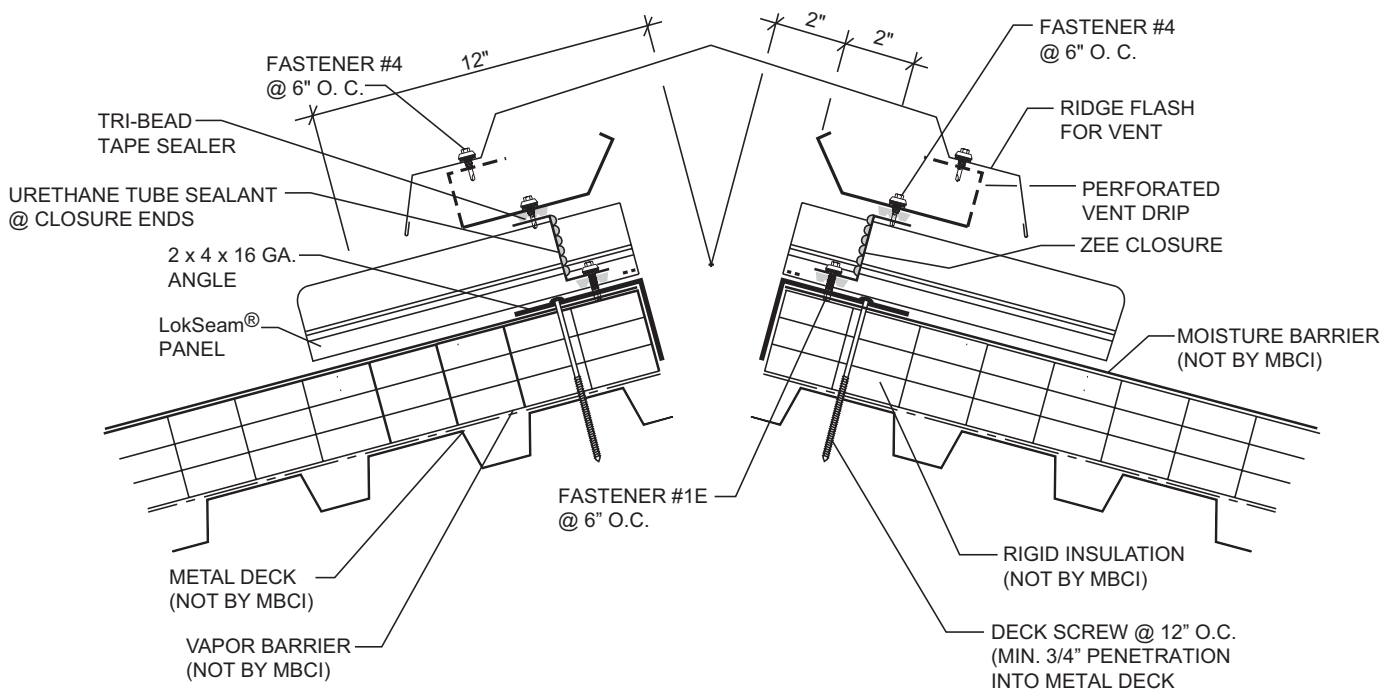

NOTES:

1. Do not use this detail with the offset cleat method of attachment at the eave or valley.
2. Vented ridge detail should be used in conjunction with soffit and/or eave vents to provide proper circulation and to prevent weather infiltration during high winds.
3. Install back-up plate and zee closure as in Notes 2-6 above.
4. Attach vent drip to zee closures with Fastener #4 at 6" o.c. Seal laps in vent drip with urethane sealant.
5. Attach ridge flash to vent drip with Fastener #4 at 6" o.c.

DETAILS

FLOATING VALLEY OVER METAL DECK

PANEL END DETAIL

FILL END OF RIB WITH URETHANE SEALANT

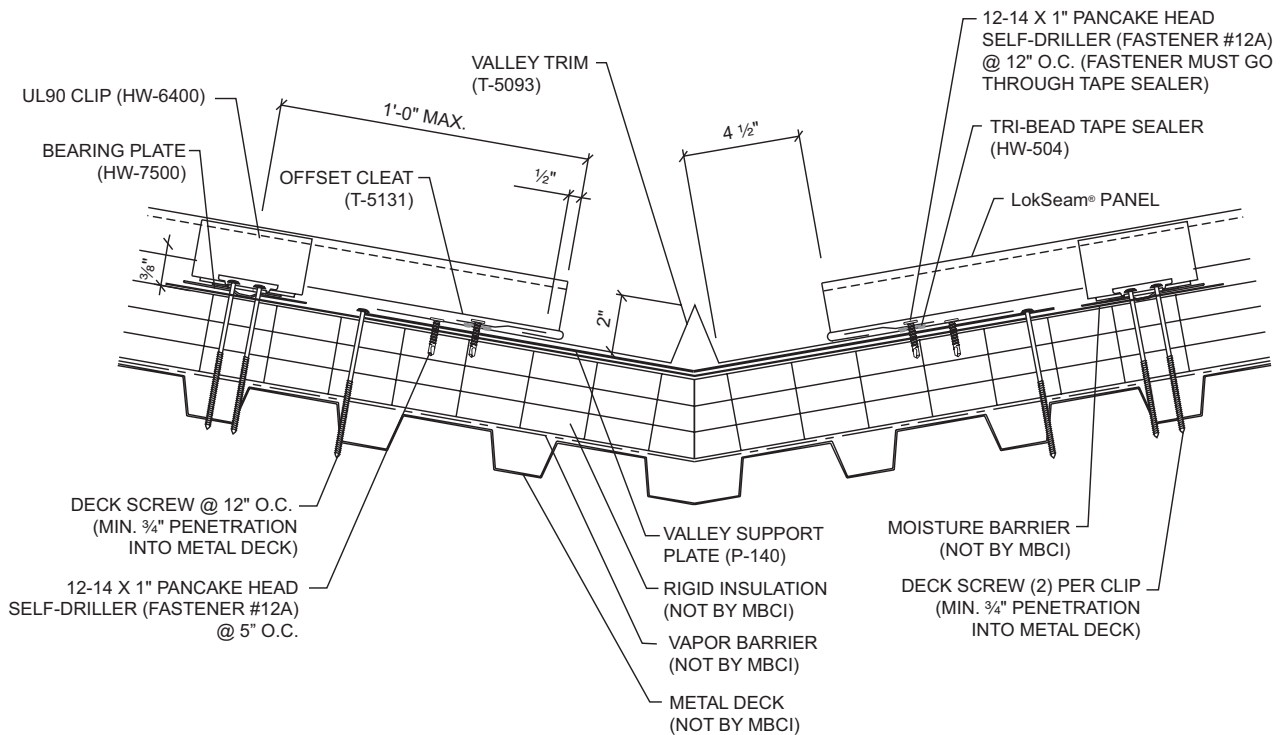
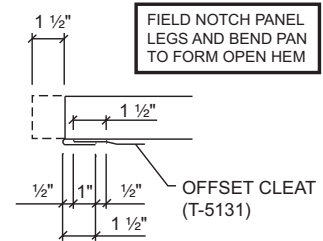
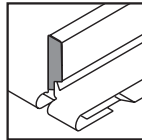

NOTES:

1. For valleys longer than 30', use extended valley trim (see page LS-22).
2. Panels must be attached to the substructure at the ridge, high eave or hip to prevent them from sliding downslope.
3. Offset cleat is installed continuously along slope of valley over Tri-Bead tape sealer with Fastener #12A at 1'-0" o.c. **FASTENERS MUST GO THROUGH TAPE SEALER.**
4. **Add 1 1/2" to panel length for panel hem.**
5. See "Panel End sealant Detail" on page LS-36 to seal panel ends at valley.

DETAILS

FIXED HIGH EAVE OVER METAL DECK

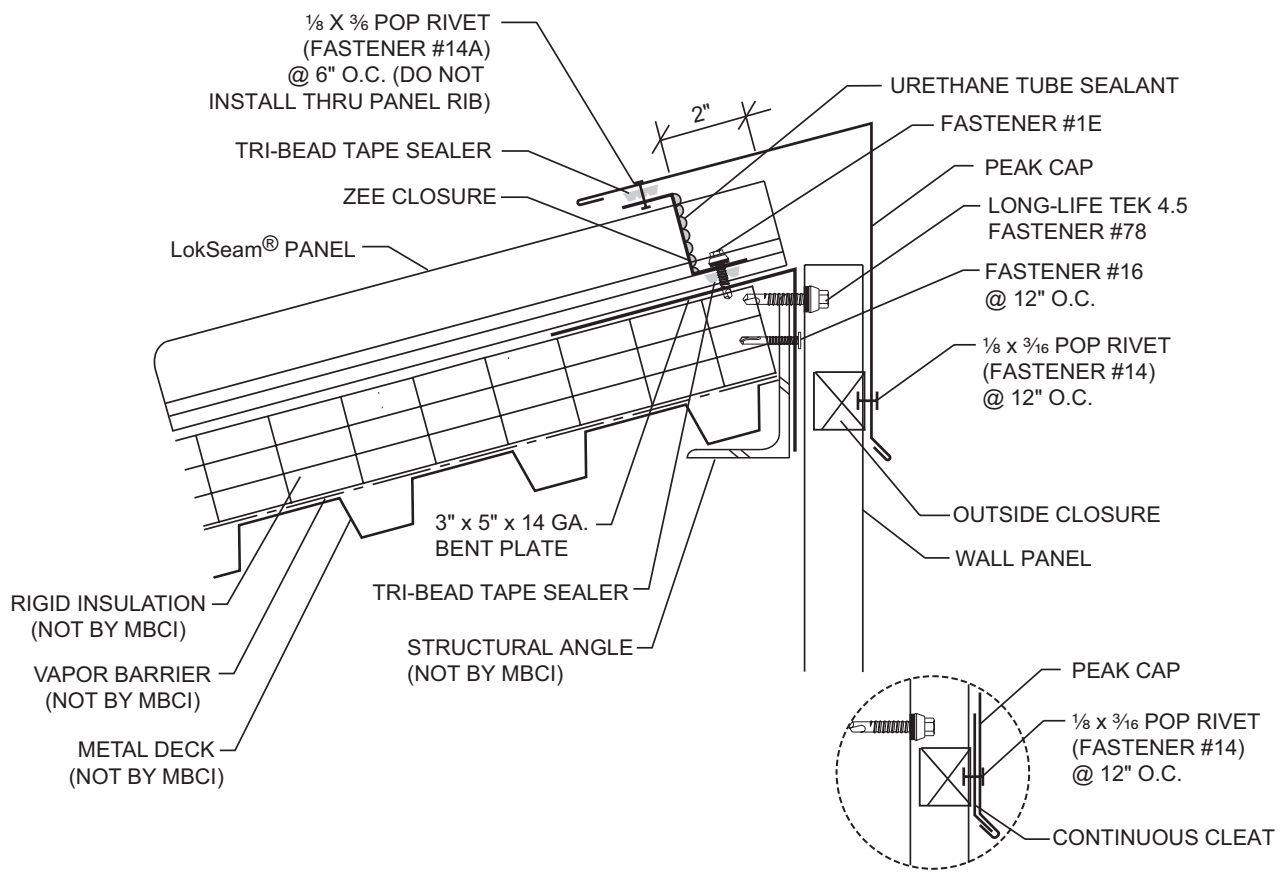

OPTIONAL CONTINUOUS CLEAT

NOTES:

1. Use this detail with a floating eave or valley detail.
2. Install panels and clips.
3. Field cut zee closures to fit panel width.
4. Install Tri-Bead tape sealer to panels. The center of the tape sealer should be 1½" from end of panel.
5. Install zee closures to panels with Fastener #1E at 6" on center.
6. Seal end of zee closure to panel seam with urethane sealant. Install Tri-Bead tape sealer to top of zee closures.
7. Attach peak cap to zee closure with Fastener #4 at 6" on center.

DETAILS

FLOATING EAVE WITH EAVE TRIM OVER METAL DECK

PANEL END DETAIL

FILL END OF RIB WITH
URETHANE SEALANT

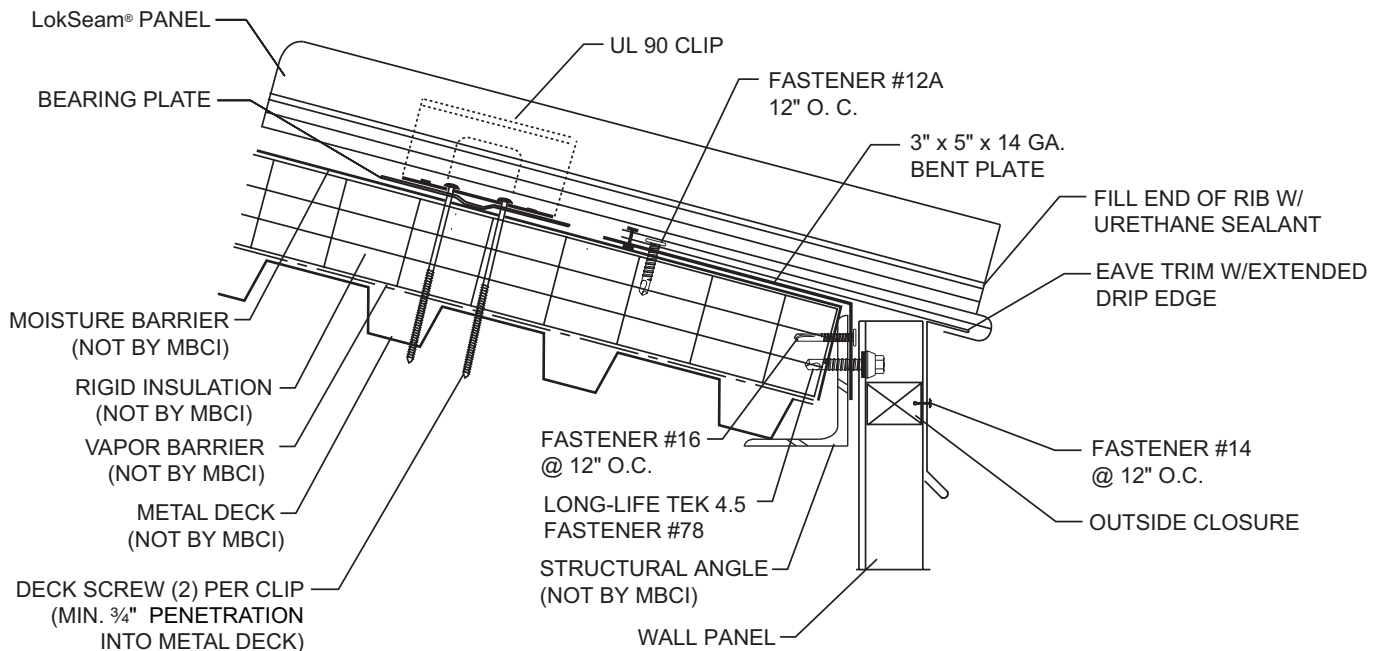
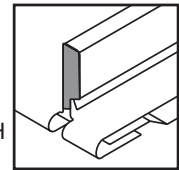

NOTES:

1. Panels must be attached to the substructure at the ridge, high eave, endlap or hip to prevent them from sliding downslope.
2. Attach eave trim to bent plate at eave with Fastener #12A at 12" o.c.
3. Attach gutter straps to gutter with Fastener #14A at 3'-0" o.c.
4. To field hem panel, see page LS-35.
5. See "Panel End Sealant Detail" on page LS-36 to seal panel ends.

DETAILS

FLOATING EAVE WITH GUTTER OVER METAL DECK

PANEL END DETAIL

FILL END OF RIB WITH
URETHANE SEALANT

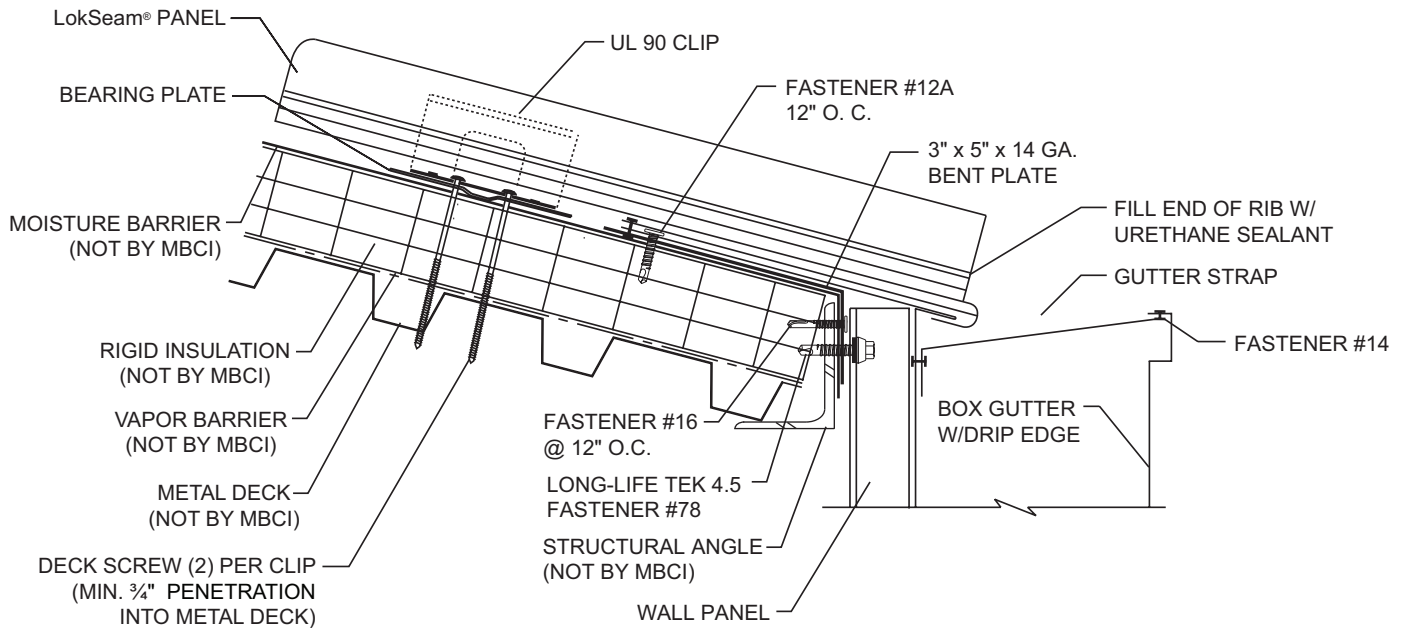
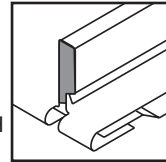

NOTES:

1. **The floating gutter detail should be used when ridge, high eave or endlap is fixed to the substructure. Panels must be attached at one of these points to prevent them from sliding downslope.**
2. Install gutter to bent plate at eave with Fastener #12A at 12" o.c.
3. Attach gutter straps to gutter with Fastener #14A at 3'-0" o.c.
4. To field hem panel, see page LS-35.
5. Notch panel hem for gutter strap.
6. **See "Panel End Sealant Detail" on page LS-36 to seal panel ends.**
7. The above gutter should not be used in areas that experience snow loads of 10 PSF or higher. See page LS-48 for the gutter detail for these areas.
8. This detail may be used on roofs with pitches of 3:12 or greater. For roofs with pitches less than 3:12, call MBCI.

DETAILS

FLOATING RAKE OVER METAL DECK

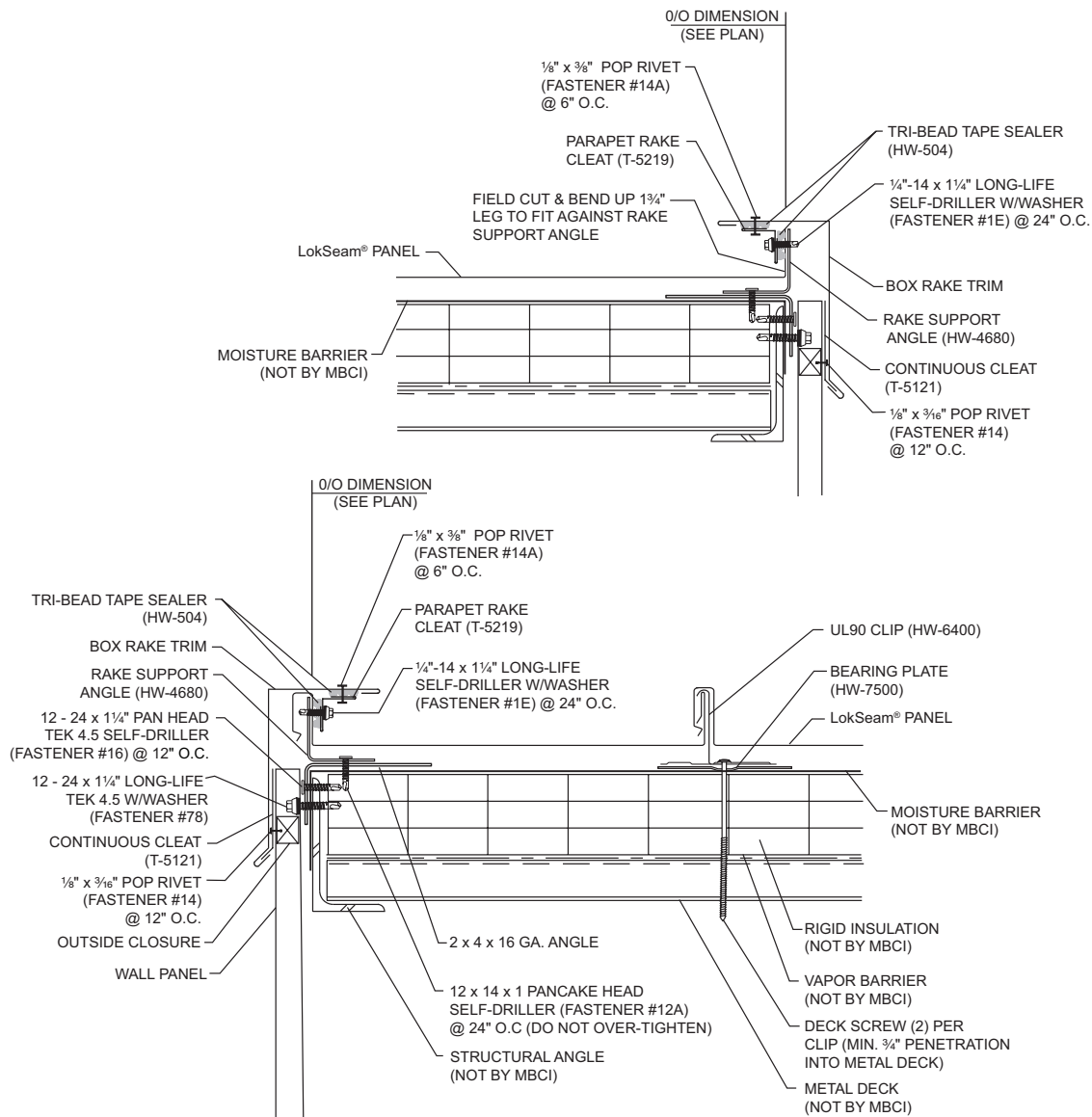

NOTES:

1. The top dimension of the rake trim will be affected by the wall panel thickness.
2. Install floating rake support with Fastener #12A, 2'0" o.c. Install fasteners in the center of the slots in the rake support (do not over tighten to allow the rake support to float).
3. Engage the female leg of the panel over the rake support.
4. Apply Tri-Bead tape sealer to vertical leg of panel. Install parapet rake cleat to panel leg with Fastener #1E at 2'-0" o.c.
FASTENERS MUST GO THROUGH THE RAKE SUPPORT.
5. Apply Tri-Bead tape sealer to the top of the parapet rake cleat and attach rake trim to parapet rake cleat with Fastener #14A at 6" o.c.
6. Use a continuous cleat to hold bottom of rake trim in place. Fasten continuous cleat at each high rib of wall panel.
7. If roof finishes on module, finishing detail will be similar to starting detail. If roof finishes off module, field cut and bend last panel run to fit against floating rake support. Install parapet rake cleat and rake trim as previously described.
8. If rake trim is not to be immediately installed, temporarily fasten panels to rake support to prevent wind damage.

DETAILS

FIXED PARAPET HIGH EAVE OVER METAL DECK

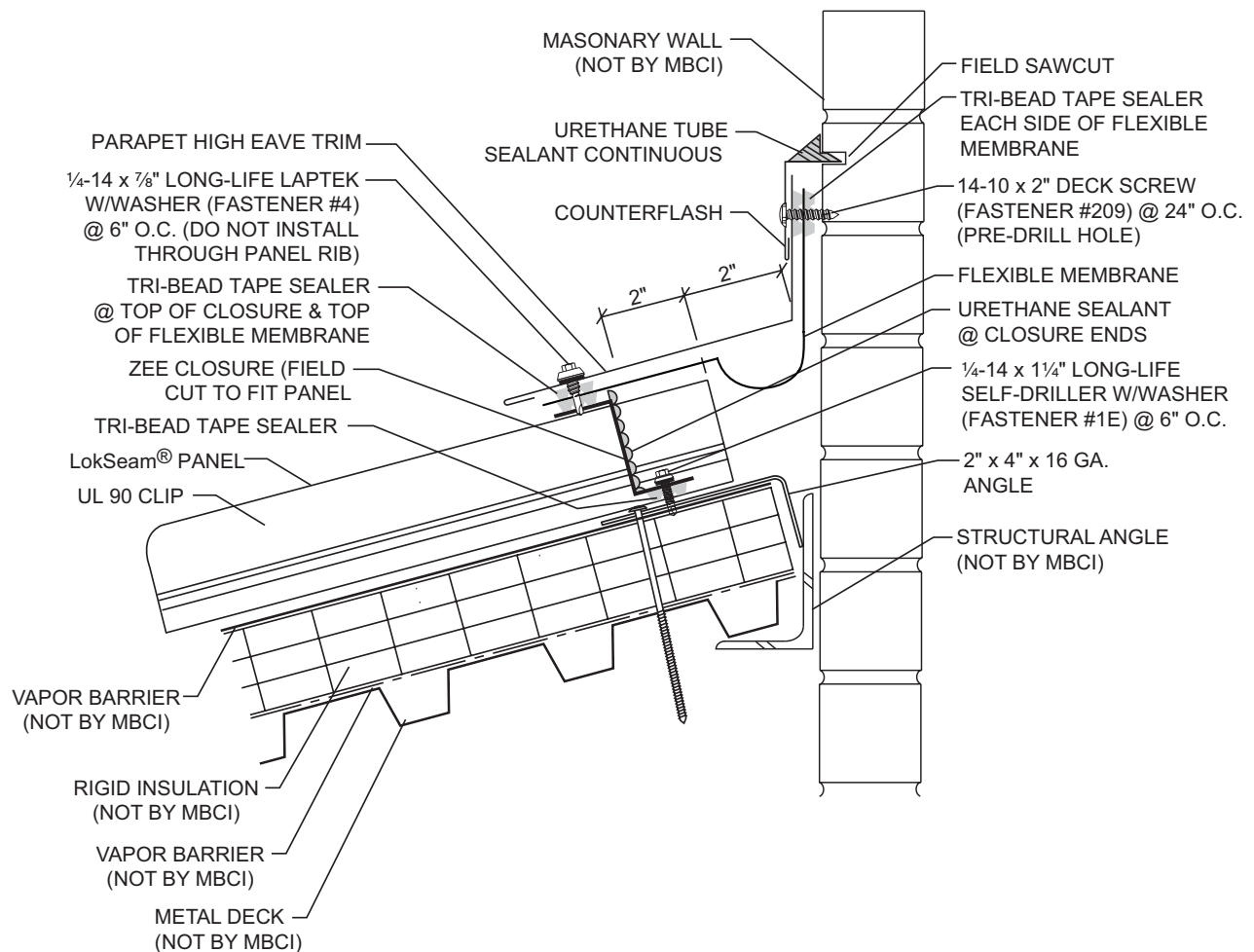

NOTES:

1. Use this detail with a floating eave or valley detail.
2. Install panels and clips.
3. Field cut zee closures to fit panel width.
4. Install Tri-Bead tape sealer to panels. The center of the tape sealer should be 1½" from end of panel.
5. Install zee closures to panels with Fastener #1E at 6" on center. Vertical leg of zee closure should be 2" from end of panel.
6. Seal end of zee closure to panel seam with urethane sealant. Install Tri-Bead tape sealer to top of zee closures.
7. Install Flexible membrane over Tri-Bead tape sealer. Apply a second layer of Tri-Bead tape sealer on top of the flexible membrane.
8. Attach parapet high eave trim to zee closure with Fastener #4 at 6" on center.

DETAILS

FLOATING PARAPET HIGH EAVE OVER METAL DECK

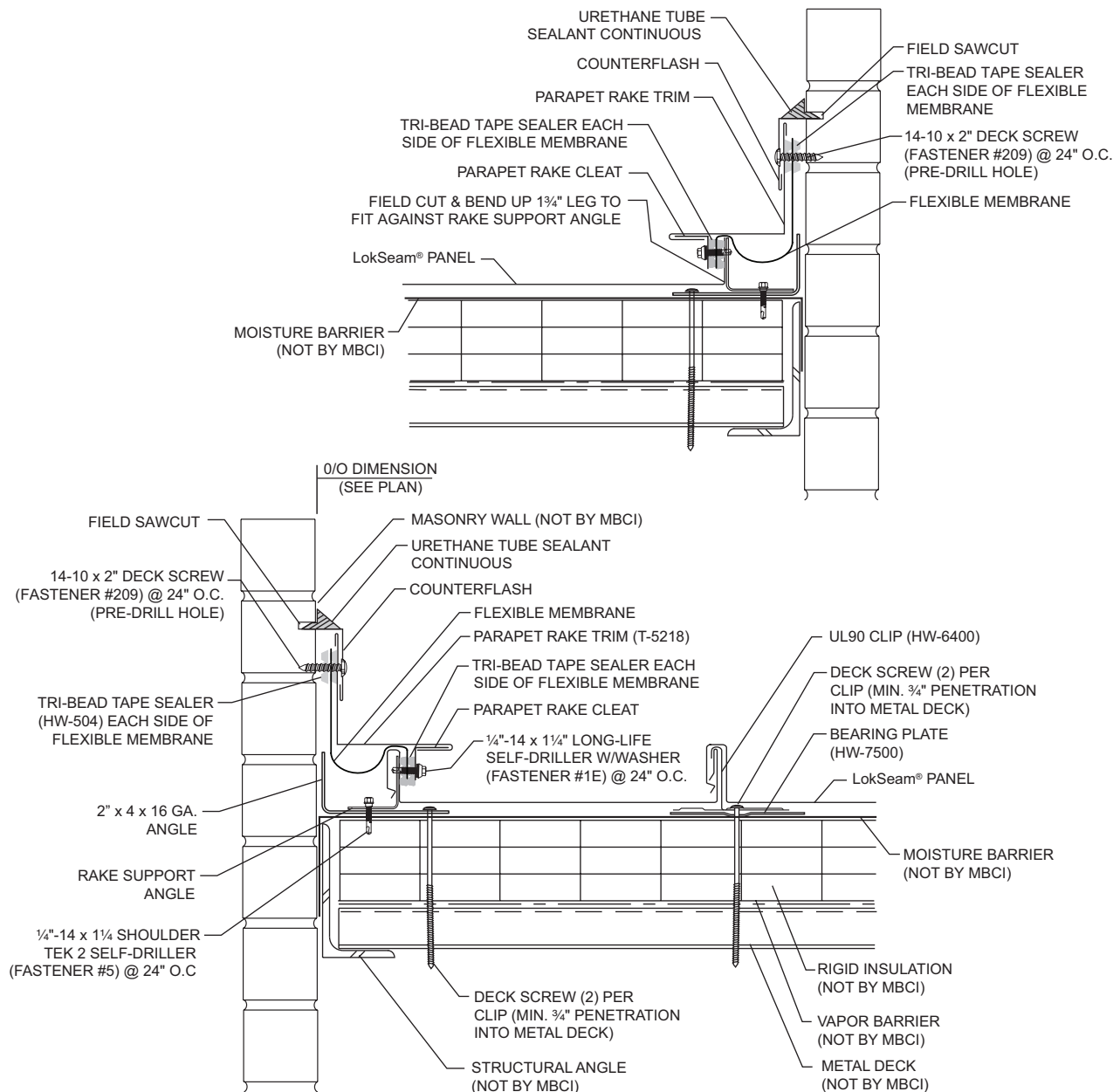

NOTES:

1. Install floating rake support with Fastener #5, 2'-0" o.c. Install fasteners in the center of the slots in the rake support.
2. Engage the female leg of the panel over the rake support.
3. Apply Tri-Bead tape sealer to vertical leg of panel. Install flexible membrane over the Tri-Bead tape sealer and apply a second layer of Tri-Bead tape sealer over the flexible membrane. Install parapet rake cleat to panel leg with Fastener #1E at 2'-0" o.c.
FASTENERS MUST GO THROUGH THE RAKE SUPPORT.
4. Engage open hem of parapet rake trim onto parapet rake cleat. Attach flexible membrane and top leg of parapet rake trim to parapet wall with an appropriate fastener, depending upon wall substrate.
5. If roof finishes on module, finishing detail will be similar to starting detail. If roof finishes off module, field cut and bend last panel run to fit against floating rake support. Install flexible membrane, parapet rake cleat and parapet rake trim as previously described.

NOTES



mbci.com