

**BUILDING MAINTENANCE
MANUAL**

METAL BUILDING MAINTENANCE MANUAL

Use the spaces below to record your building information for easy reference when contacting us for assistance.

BUILDING INFORMATION

Building Owner

Name _____

Address _____

Phone _____

Additional contact info _____

Authorized Builder

Name _____

Address _____

Phone _____

Additional contact info _____

Project Information

Work Order Number _____

Date of Completion _____

SAFETY SYMBOL



Use of this symbol in the manual indicates a potential safety concern. Please read the accompanying text passages carefully for your own safety, for the safety of others and to prevent damage to your metal building.

***An effective building maintenance program may
help reduce the cost of insurance!***

Replacement parts and service are available through your local authorized Builder. If an authorized Builder is not available call one of our company's regional offices and ask for customer service. Please have the work order number or project number handy when calling as this will help us locate the files for your project and aid us in providing you with assistance or parts as needed

STATUS AT TIME OF PRINTING

We pursue a policy of continuous, ongoing development to ensure that our buildings remain state-of-the-art in technology, combining the latest in high quality materials and safety features. For this reason, it is possible that the features described in this manual may differ from those on your building.

TABLE OF CONTENTS

Introduction

- Scope
- Frequency of Maintenance

Safety

- General Safety Recommendations

Roof Maintenance

- Leak Repair
- Foot Traffic
- Drainage
- Additions to Roof
- Dissimilar Metals
- Maintenance Guidelines

Snow Removal

- When to Remove Snow

Structural Modifications

Accessories

- Translucent Roof Panel Fall Protection
- Translucent Panel Maintenance Recommendations
- Eave Gutters, Valley Gutters, Downspouts and Scuppers
- Personnel Doors
- Windows
- Sliding Doors
- Ridge Ventilators
- Wall Mounted Exhaust Fans and Louvers
- Insulation

Finishes

- Cleaning and Care of Finished Paint Systems
- Touch-up/Repair of Damaged Paint
- Field Painting/Major Repair of Finish

Project Documents

INTRODUCTION

Scope

Congratulations, and thank you for choosing a metal building for your project. This manual is an important reference tool in maintaining your building. It provides guidance in inspections, adjustments, cleaning and care for your building.

Metal buildings have evolved into structures requiring minimal maintenance because of improvements in materials, design applications and fabrication techniques. However, like many other investments, your building does require some attention to maintain its value and appearance. This manual is provided to help you keep your metal building in good condition.

The information in this manual is not intended to cover major work that should be done by an authorized Builder, but only to provide a guide for periodic care.

The information contained herein is only intended to provide recommendations for maintaining a typical building; due to special features and/or the location of your building, some or all of the recommendations contained herein may not apply to your building. Prior to performing any maintenance work on your building, you should consult applicable local and federal safety requirements and your local building contractor. Failure to provide regular maintenance, as set forth in this manual, may void any warranty, actual or implied, that may be applicable to a building or its components.

Frequency of Maintenance

The frequency with which preventive maintenance activities should be performed will depend on several factors including the specific maintenance task, the environmental influences based on the location of your building, the age and condition of the building and your commitment to a preventive maintenance program.

Your maintenance schedule should begin immediately after a building is erected, modified or repaired.

We recommend most maintenance activities be performed at least twice annually. For buildings that are located in areas that have moderate to severe winters, inspections are recommended in the spring closely following winter and in the fall early enough to complete any necessary repairs prior to winter. Additional inspections and maintenance may be needed following severe or unusual storms.

Maintenance activities should be performed more frequently than twice per year on buildings located in coastal areas, areas subject to industrial pollution and areas with high humidity as a result of the increased exposure to corrosive elements in these areas. In addition, buildings used for activities that are potentially detrimental to the building such as indoor pools, animal confinement or activities that generate corrosive chemicals should have maintenance activities performed more frequently.

SAFETY



General Safety Recommendations

Always follow and comply with all federal, state and local rules and regulations including, but not limited to, OSHA regulations when performing routine building maintenance and/or renovations. Failure to follow these regulations could result in personal injury or death to you or bystanders.

Always use OSHA approved Fall Protection when working in elevated places; do not walk on wet roof panels; do not walk, step or sit on skylights (translucent roof panels), ridge-caps or gutters because of the possibility they may collapse.

Always comply with governing regulations, use proper safety equipment, and follow appropriate safety procedures for each maintenance activity.

In addition, do not forget to consult your insurance carrier and fire hazard inspector about building maintenance or major renovations. They can be valuable resources for the latest information on safety and risk management.



ROOF MAINTENANCE

WALKING ON ANY ROOF IS DANGEROUS. SAFETY MUST ALWAYS BE TOP PRIORITY WHEN PERFORMING MAINTENANCE ON YOUR ROOF SYSTEM. ALWAYS USE ALL FALL PROTECTION AND PERSONAL SAFETY EQUIPMENT REQUIRED BY OSHA AND OTHER REGULATORY AGENCIES. ALWAYS COMPLY WITH ALL SAFETY GUIDELINES WHETHER CUSTOMARY, REGULATORY OR STATUTORY. FAILURE TO FOLLOW THESE REGULATIONS CAN RESULT IN SERIOUS INJURY OR DEATH. YOU MAY ALSO BE SUBJECT TO SUBSTANTIAL FINES FOR NONCOMPLIANCE.

Always use extreme caution when walking on roofs with steep slopes, near roof edges, or on roofs that are wet or covered with ice or snow. Insure that all maintenance personnel are adequately trained in safety procedures and that all safety equipment is in proper working condition.

When performing roof maintenance, always take the following precautions:

- Use fall protection and other safety equipment as required.
- Do not walk on roof flashings such as gutter, rake, hip or ridge.
- Do not walk on Light Transmitting Panels (LTPs). They will not support a person's weight.
- Guard all LTPs and roof openings.
- Step only in the panel flat, directly on, or in close proximity to a supporting roof structure.

Your new roof is designed to provide years of protection with very little maintenance. However, no roof is immune to severe weather or completely maintenance free. To keep your roof performing as it should, a comprehensive maintenance program must be implemented.

Your roof should be inspected periodically and whenever any of the following conditions occur:

- **After a fire, vandalism or known damage to an adjacent roof area.**
- **Exposure to severe weather conditions, including high winds, hail or abnormally heavy rains or ice and snow.** Items to check for after high winds include: Debris from nearby trees, loose flashing or other roof components, punctures from falling limbs or loose flashing, and loose fasteners. After a hail storm, check roof for punctures, damaged trim, and loose fasteners. After abnormally heavy rains, check roof and gutters for ponding water. Also check all roof curbs, roof

penetrations and any special trim conditions to ensure that water is not ponding upslope from these areas. Check trim and plumbing pipes for damage from moving ice. Check for loose fasteners at trim and endlaps. Replace stripped-out fasteners by removing existing fastener; apply urethane sealant into hole; install an oversize, long-life fastener into hole.

- **After other trades have been on the roof for any reason.** Inspect the roof for damage caused by workers including chemical or solvent spills, scratches in the paint or Galvalume coating, excessive foot traffic and punctures. Make sure that any debris or scrap left behind by the workers is removed from the roof immediately. Avoid using cutoff saws and welding equipment over the roof. In cases where this is not possible, the roof must be adequately protected. A fire cloth is recommended. Items such as drill shavings, wire, metal scrap and other debris can corrode and damage the roof. Sharp pieces of metal, such as those left by a nibbler, can stick in a worker's shoes and scratch the paint as they walk on the roof.

Mortar or concrete will etch the paint or Galvalume coating. Roof panels in areas where there is a possibility of any masonry product being spilled on them should be protected. In the event that the panels do have a masonry product spilled on them, they should be cleaned and the panels rinsed. Should any solvent or chemical be spilled on the roof, clean up immediately and thoroughly rinse the affected area. Panels should be cleaned with a mild detergent.

Leak Repair

Never allow workers to "fix" leaks by applying caulk, elastomeric membranes, plastic roof cement, etc. to the roof surface. This is never a long-term solution for repairing a leak. Surface applied caulks and compounds will eventually lose their bond to the metal. This will allow water to become trapped between the repair material and the roof panel, which will cause severe corrosion. Leaks at panel or trim joints, should be repaired by disassembling the metal joint and reinstalling the proper sealant between the metal layers. Leaks caused by roof punctures must be evaluated on an individual basis. In some cases, the affected roof panel may need to be replaced.

Always consult the roof manufacturer before initiating repair work as improper repairs can lead to further leaks and/or damage to the roof system, as well as, impact or void warranties that may have been sold as a part of your roof purchase and installation. The manufacturer can give you helpful information as to how to make the repair and can give you a list of "Certified Installers" in your area that you can contact about performing the repair work in the event your original installer is not available to perform the necessary work.

Foot Traffic

Keep foot traffic to a minimum. Heavy foot traffic can cause ponding on low pitched roofs. This is particularly true just upslope from the eave and at endlaps. Always walk in the flat of the panel near a supporting roof structural. Do not walk on trim or in gutters. On bare Galvalume roofs, excessive foot traffic may cause black burnish marks. If regular foot traffic is planned for a roof, provisions should be made for a properly designed and installed roof walkway system.

In order to limit access to the roof, roof hatches or access ladders should be locked at all times. A sign should be posted at the point of access, stating that only authorized personnel are allowed onto the roof. In addition, a log book should be kept of all visits to the roof and the reason for such visits.

Drainage

In order for your roof to perform as intended, water must properly drain from the roof. Following are things to avoid:

- Do not allow anything to be installed on your roof that will cause water to pond.

- Keep roof free of debris and keep debris out of gutter to allow water to quickly drain from roof.
- Do not use wood blocking to hold equipment off of panel seams. This blocks the flow of water and holds moisture. Also, if the wood is treated, it may contain salts or copper sulfate which will deteriorate the roof, and void warranty coverage.
- Do not allow water to cascade onto the roof from an adjacent roof.
- Do not allow rooftop AC units or evaporative coolers to drain onto the roof. The condensate from AC units contains dissolved copper ions which will cause galvanic corrosion. The water from evaporative coolers contains high salt concentrations which will cause severe corrosion. Use PVC pipe to carry the condensate to the gutter.
- Anything that traps or holds moisture on a roof will cause premature corrosion.

Additions to Roof

All additions to the roof, including but not limited to, roof curbs, pipe penetrations and HVAC units should be consulted with the manufacturer prior to installation in order to verify if special requirements

Dissimilar Metals

Never allow your Metal Building cladding to come in contact with, or water runoff from, any dissimilar metal including but not limited to: copper, lead or graphite. Failure to adhere to this requirement will cause your cladding to rapidly deteriorate due to galvanic corrosion and will void all warranties. Common abuses of this requirement include: lead hats for plumbing vents, copper lightning rods and/or cable, copper trim, existing copper gutter that drains water onto your panel, and condensate from rooftop AC units draining onto roof.

Maintenance Guidelines

DO	DON'T
<ul style="list-style-type: none"> • Inspect your roof regularly. • Walk in the flat of the panels near the structural supports. • Keep roof, gutters and downspouts free of debris. • Inspect for damage after heavy storms. • Caution workers on roof to protect against roof punctures. • Remove excessive ice and snow accumulations as necessary. • Inspect and reseal as necessary all roof curbs and other penetrations with urethane sealant. • Always get manufacturer's approval before making any modifications to the roof. • Always use long life fasteners and stainless steel rivets on the roof and trim. • Repaint any areas that are susceptible to rust as required. 	<ul style="list-style-type: none"> • Allow your roof to be neglected. • Walk on the panel ribs or on flashings. • Allow debris of any kind to collect on roof. • Allow damage from storms to go undetected and cause ancillary damage. • Drop sharp or heavy objects on roof. • Use metal shovels or other tools that can scratch the paint or Galvalume coating on the panels. • Use plastic roof cement or butyl or silicone caulk anywhere on the roof. • Assume that minor additions or modifications will not cause any problems. • Use zinc-plated fasteners or carbon steel rivets. • Allow rust or rust stains to build up on roof.



SNOW REMOVAL

When to Remove Snow

In keeping with Section A9 guidelines of the 2010 Metal Building Manufacturers Association Manual:

Defining a specific depth of snow that a building has been designed to support is not possible because the density of snow is variable and dependent upon weather conditions both during and after a snowfall, as well as affected by the total depth of snow at a location. With the variability of snow density, it is possible for conditions to exist that exceed the designs specified by the building codes. Snow density also changes as the snow melts. Not all water drains off the roof as the underlying snow absorbs some water from the melted snow above. This leads to ice build-up on the roof as the temperature varies from day to night.

Fresh snowfall may weigh as little as 10 to 12 pounds per cubic foot (pcf) but the density will greatly increase as it compacts and becomes heavier with water. Typical densities on a roof will range from 16 pcf to 30 depending on snow depth. When there is snow on the roof of a building and rainy conditions occur, excessive loads can develop rapidly. Snow acts as a sponge in these conditions and loads can approach the weight of water, 62.4 pcf or 5.2 pounds per square foot (psf) per inch of depth. Rarely will a cubic foot of snow and ice equal the weight of water due to the expansion that takes place as water freezes. However, these conditions must be monitored with extreme caution.

Snow will build up in areas around firewalls, parapet walls, valleys, dormers and on lower roof levels where a step in the roof occurs. All modern building codes require design for snow build-up conditions so that the structural systems in these areas can support the additional loads. However, due to the variability of snow density, as noted above, it is possible for conditions to exist that exceed the designs specified by the building codes.

While it is not possible to accurately determine a specific depth of snow that is considered a safe maximum, an approximation can be made. The first step is for the building owner to obtain information as to the snow load the building has been designed to carry. For example, a building designed for a 30 psf snow load can be at design load with just 18 inches of snow at a density of 20 pcf and could be overloaded with less than a foot of snow under wet conditions. Clearing snow from the roof is, of course, the only way to relieve this. It is recommended by Factory Mutual that roofs be cleared of snow when half of the safe maximum snow depth is reached. The maximum snow depth can be estimated based on the design snow load and the density of the snow and/or ice buildup.

STRUCTURAL MODIFICATIONS

Before making any structural modifications, you must contact a design professional for assistance. Always make certain you have a copy of the complete instructions and related information regarding any modifications from your design professional prior to making any modification.

Some typical major modifications include but are not restricted to:

1. Removal or relocation of X-rod or other types of bracing
2. Cutting into or removal of any structural component
3. Removal or relocation of frame flange brace angles
4. Addition of any load not specifically included in the certification letter for the original building design
5. Adding adjacent building(s), especially if new one is taller.

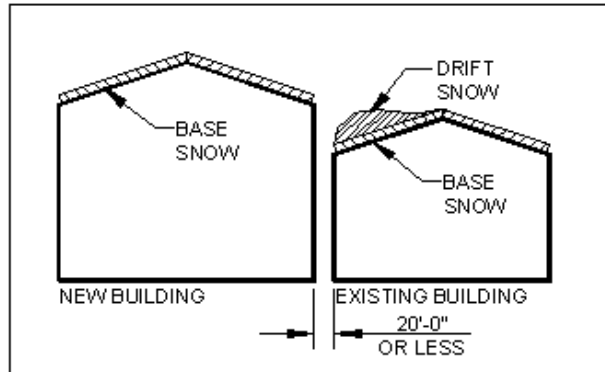

Placing a new taller building adjacent to an existing building can result in snow drift loads on the existing building that were not considered in the original design. The new snow drift load could cause the original building to collapse. When adding a new building within 20 feet of an existing building, the existing building should be checked for potential additional loads and reinforced if necessary.

ACCESSORIES



Translucent Roof Panel Fall Protection

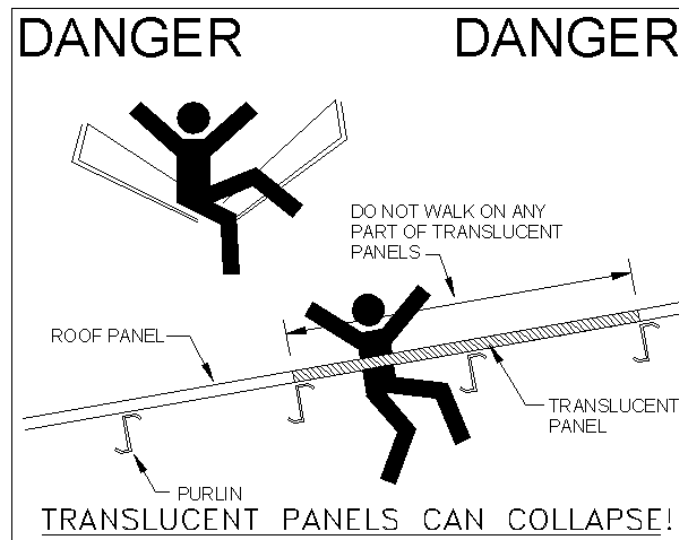

It is important to understand that OSHA considers skylights a roof opening, and as such, it is the building owner's responsibility to provide fall protection. Translucent roof panels, commonly known as skylights and/or fiberglass reinforced panels (FRP), are not made to support concentrated loads such as foot traffic. Translucent panels are designed to allow natural light into a building, yet they are capable with proper installation and maintenance of resisting wind and snow loads. Stepping on a translucent panel could cause the panel to collapse causing the person to fall and sustain serious injury.

Accumulations of dirt and/or snow on a roof can easily conceal the location of a roof translucent panel. As a result, it is highly recommended that each person planning to go on the roof review the roof framing plan drawing which is part of the erection drawings for your building to identify the locations of rafters and purlins and "as-built" roof translucent panels. An up to date copy of the roof framing plan drawing that accurately shows the locations of roof translucent panel should be kept readily available and carefully reviewed by everyone who will be on the roof - **BEFORE** they go on the roof.

Although the translucent roof panels have a “DO NOT WALK ON THIS PANEL” warning label on each panel these warning labels may be covered with dirt, debris and/or snow; this is why it is imperative that people know the location of these panels BEFORE going on the roof. These warning labels must not be removed for any reason. (Note: The actual label used may vary somewhat from the sample shown.)



Roof and Wall Translucent Panel Maintenance Recommendations

To maintain good appearance and long life, translucent panels or fiberglass reinforced panels (FRP), especially roof panels, should be hosed down or washed periodically. Cleaning removes the accumulation of dust, dirt and debris which can combine with sunlight and wind to attack exposed surfaces, both chemically and abrasively. When cleaning these panels mild, non-abrasive cleansers should be used. Avoid the use of compounds containing ammonia or chlorine since they may cause panel discoloration.

Translucent panels should be cleaned periodically to allow for maximum light penetration and longevity. Depending on your buildings location it may be necessary for these panels to be cleaned on a more frequent basis. If the translucent panel is severely deteriorated replacement should be considered.



Eave Gutters, Valley Gutters, Downspouts and Scuppers

When working on or inspecting gutters, downspouts and/or scuppers, be aware of safety issues in doing so including, but not limited to, falling from the roof and injuries from using a high-pressure hose for cleaning. Always follow OSHA and other governing requirements for fall protection and tie-off.

Visually inspect gutters for accumulation of debris that would prevent gutters or downspouts from operating properly. Clean out all accumulated debris regularly using a water hose with sufficient pressure to flush dirt and small debris. Larger items such as rocks, cans, limbs and heavy accumulations of leaves or pine needles should be removed by hand. It is recommended that suitable gloves be worn. Gutter obstructions can cause dirt to build up which holds moisture that can cause premature rusting and allow standing water to accumulate on the roof that may result in a leak through an improperly sealed sidelap or endlap. Blocked downspouts can produce the same results if they are not allowed to drain freely. The weight of accumulated debris in a gutter compounded with ice and snow could exceed the load carrying capacity of the gutter and gutter support clips and cause the gutter to fall. Check for and repair any loose connections.

Personnel Doors

Although one person can perform most minor door maintenance, some activities such as complete removal or rehunging of a door may require two or more people to prevent injury.

Personnel doors must be checked periodically for the following:

1. Check for tightness of locksets, closure hardware and hinges
2. Check for and repair any loose fasteners on all doors
3. Check for and repair any misalignment of door leaf and its frame, making sure the leaf does not rub, bind or have too much of a gap between leaf, jambs, headers and/or threshold
4. Lightly oil mechanical parts including hinges
5. Check for and repair any wind damage and other physical damage
6. Check for any delamination of door leaf's skin and replace leaf if needed
7. Check for and repair any air leaks with appropriate sealant, adjustments, and replacement parts

Windows

Windows usually require very little maintenance. Lubricate the window track, clear sill drain holes and inspect sealant at top and sides of windows. Check for and repair any air and water leaks at windows and overhead doors. Remove all old caulking and apply new caulking as required.

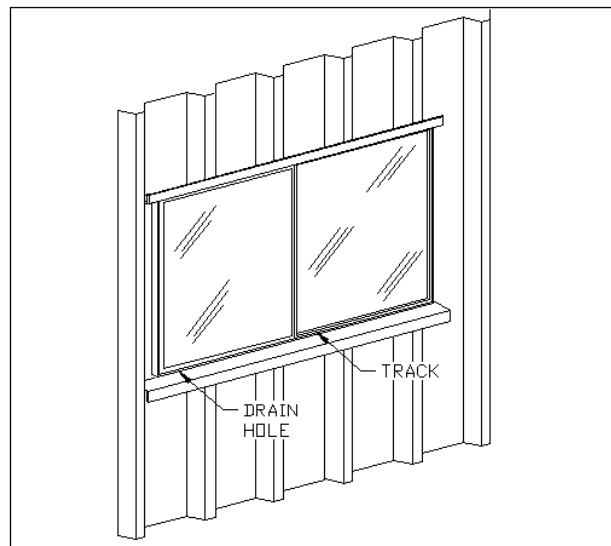

Sliding Doors

Lubrication of door casters is generally not required as casters are packed with grease and sealed by the door manufacturer. If a sliding door becomes difficult to operate, adjustments to the base guide or caster height may be necessary. Check for and remove any dirt or debris in the door guide.

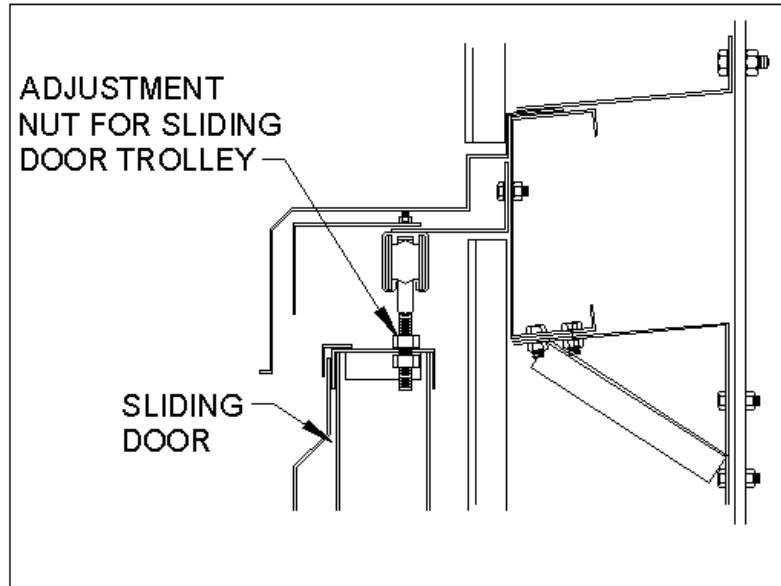

Overhead Doors

Check and tighten the bolted connections of the framing supporting an overhead door as needed. Contact the door manufacturer if the door becomes difficult to operate or is out of alignment. Only a qualified technician should perform torsion spring adjustments.



Ridge Ventilators

Safety concerns when working on a ridge ventilator include but are not limited to falling from the roof and the potential for falling through the roof opening should the ventilator be removed. Make sure to use proper fall protection and tie-off when working in an elevated location. The top of the ventilator will usually have an insect screen that prevents access to the interior of the ventilator. Maintenance or repair activities to the operational components inside of the ventilator will require accessing the unit from below, inside the building or by removing the ventilator and turning the ventilator over to gain access. If a ventilator is removed for maintenance be sure to properly mark and cover the opening in the roof where the ventilator was removed to prevent a fall hazard.

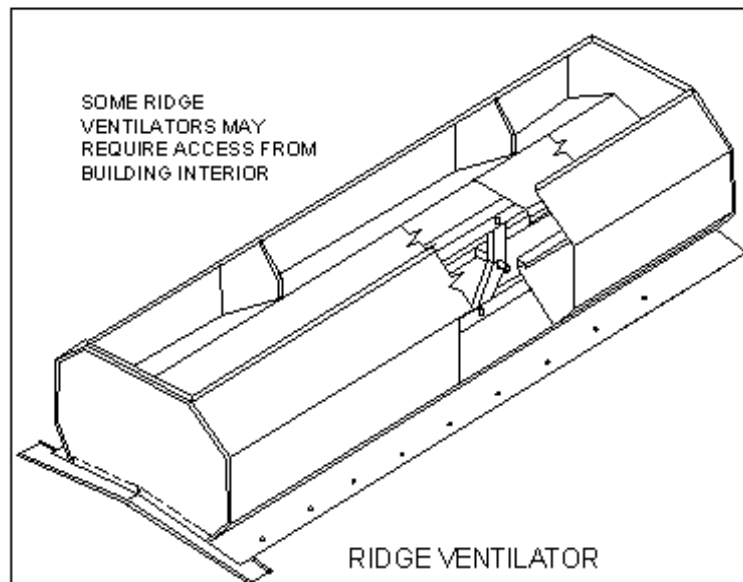

Vents that do not have moving parts will require very little maintenance. Ventilators containing moving parts such as pulleys, rollers or cranks for flue operation will require periodic lubrication at pivot points. Simple operation from time to time will aid in breaking corrosion loose

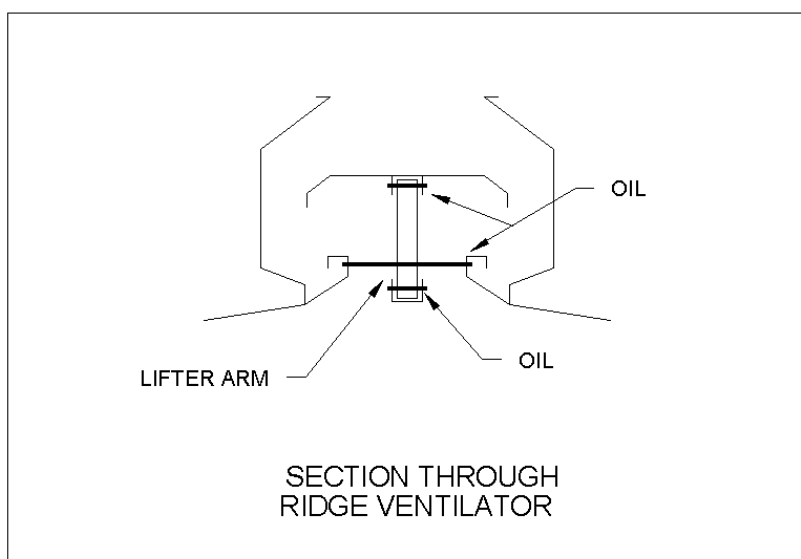



Wall Mounted Exhaust Fans and Louvers

Safety concerns when working on a wall mounted exhaust fan or louvers include, but are not limited to, falling if the fan or louver is elevated and possible electrical shock hazards if the exhaust fan or louver is electrically operated. Make sure that you have proper fall protection equipment and that the electric power to any electrical equipment is turned off and properly locked-out or tagged-out before maintenance is performed.

Check operation of manual louvers and louvers electrically interlocked with exhaust fans, and repair or replace as needed. Fixed louvers that do not have moving parts will require very little maintenance. Operable louvers containing moving parts such as vanes will require periodic lubrication at pivot points. Simple operation from time to time will aid in breaking corrosion loose. A vibrating ventilation fan indicates that there may be a problem with the fan. Not only can a vibrating fan cause damage to itself, but may cause damage to the building as well. A fan that is vibrating needs to be checked promptly and appropriate corrective measures taken before additional damage is caused. Many times a vibration could mean a bent fan blade or worn belt.



Insulation

Although we are not aware of any long-term health related concerns with fiberglass blanket insulation, you should always wear protective clothing such as long sleeves, long pants, gloves, eye protection and/or a respiratory filter when working with insulation. Information concerning: RECOMMENDED WORK PRACTICES FOR FIBERGLASS, ROCK WOOL AND SLAG WOOL (SVF) INSULATION PRODUCTS is available from the North American Insulation Manufacturers Association (NAIMA, www.naima.org)

Check for wet or damaged insulation periodically. Wet or damaged insulation transfers heat, whether from the heating system in winter or from the sun in summer, which is not only costly but also uncomfortable for the people in your building which may reduce their productivity. If left unattended, wet insulation will cause panel and component corrosion. All wet insulation should be removed and replaced or otherwise opened and allowed to dry fully.

Torn insulation backing, which is usually white vinyl or foil (called a water vapor retarder), can allow moisture (water vapor) inside the building to move directly through the insulation. This process can cause condensation within the insulation causing the insulation to be less effective and on the inside surface of the roof and wall panels causing the panels to deteriorate. Pressure sensitive tapes with an exposed side that matches the facing used on the insulation are available from most insulation suppliers for use in repairing a torn vapor retarder.

Pockets of extremely moist air in the building can also cause condensation problems. The following procedures will help or possibly eliminate the problem:

1. Seal small tears in the water vapor retarder with vinyl tape
2. Replace large areas of damaged insulation
3. Install fans or air exchange units to disperse pockets of moisture-laden air
4. Eliminate the source of high moisture in the building

Caution: Condensation problems are easily mistaken for roof leaks. If your building is experiencing excessive condensation have the HVAC contractor or engineer check humidity levels to determine if they are within projected values.



FINISHES

Protective clothing, protective eyewear and/or a respiratory filter may be appropriate when working with chemicals, paints or cleaners. Use appropriate caution and safety equipment when using a high-pressure hose to clean surfaces.

Cleaning and Care of Finish Paint Systems

The high-quality paint finishes used on the metal roof and wall panels will maintain their appearance and protective value for a long time if properly maintained. Improperly maintained panels will accumulate dirt and film deposits over time causing the panels to lose their original appearance; to prevent this it is important to establish a proper maintenance program to keep the finishes in prime condition.

The most important cleaning is done immediately after the erection of the building, as metal shavings are present and are somewhat magnetized because of the screw and drill rotation. Shavings are not always visible and must be swept off the roof and walls to prevent corrosion of the particles, which will stain the panel surface.

Under normal conditions, a fresh water washing two or three times per year using a regular garden hose under pressure will keep the paint finish in good condition. If the need to clean or remove surface deposits does arise, then a variety of methods maybe utilized. When used properly, the following should not affect applicable panel warranty.

1. Hot or Cold Detergent Solutions:
For use on water soluble deposits. A 5% solution in water of commonly used commercial (Non-industrial, non-bleach) detergents will not have any deleterious effect on a painted surface. These solutions should be followed by an adequate rinse of water. Use a cloth or soft bristle brush for application
2. Solvents/Alcohols:
For use on non-water soluble deposits such as tar, grease, oil and adhesives. Most organic solvents are flammable and/or toxic and must be handled accordingly. Read the manufacturer's material Safety Data Sheet (MSDS) of solvent used. Keep away from open flames, sparks and electrical motors. Use adequate ventilation, protective clothing and goggles.

Alcohols

- a. Denatured alcohol (Ethanol)
- b. Isopropyl (rubbing alcohol)

Solvents

- c. VM&P Naptha
- d. Mineral Spirits
- e. Kerosene
- f. Turpentine (wood or gum spirits)

PRECAUTIONS: DO NOT USE WIRE BRUSHES, ABRASIVES OR SIMILAR CLEANING TOOLS WHICH WILL MECHANICALLY ABRASE THE COATING SURFACE. MISUSE OR ABUSE OF ANY OF THE CLEANING AGENTS LISTED ABOVE WILL RESULT IN VOIDING OF ANY APPLICABLE WARRANTY FOR THE SURFACE AFFECTED. GRAFFITI PRESENTS A SPECIAL PROBLEM BECAUSE OF THE MANY POSSIBLE AGENTS USED, GENERALLY AEROSOL PAINT. IT IS BEST TO TRY SOAP AND WATER FIRST, THEN THE SOLVENTS. IF NONE OF THESE ARE SATISFACTORY IT MAY BE NECESSARY TO RESORT TO TOUCHUP, REPAINT OR REPLACEMENT.

Remove smudge marks from bare Galvalume. Formula 409 has proven to be somewhat effective. Lightly rub with a clean cloth and rinse with water. Do not rub more than required to remove smudge. No product will remove all smudge marks.

Remove rust stains. Soft Scrub (without bleach) and Simple Green have proven to be somewhat effective. Lightly rub with a soft cloth and rinse with water. Do not rub more than required to remove stain. No product will completely remove rust stains.

Touch-up/Repair of Damaged Paint Surface

The first step in repairing damage to your paint surface is to observe and evaluate the damage to determine which of the following steps should be taken.

Minor scratches or abrasion, metallic substrate Not exposed:

1. Clean the locale of all dirt, oil, grease or other foreign matter (see CLEANING AND CARE for the appropriate cleaning solution)
2. Lightly scuff the damage with Scotch-Brite Pads
3. Dampen a lint free cloth or tack cloth with acetone using the proper precautions for handling solvents as instructed on the MSDS or container of the solvent. This may include safety glasses, gloves, protective clothing and a respirator. Wipe the surface liberally to clean the areas to the touched up. The surface must be dry before the touch-up coat is applied. Before you use the paint, read the instruction on the container carefully.
4. When applying the touch up paint, LESS IS BEST. Apply with as small an applicator as possible. A brush similar to a finger nail polish applicator is best. Dip the brush half the length of the bristles into the paint. Tap the brush against the side of the container but do no wipe against the lip. Hold the handle near the base and apply a light pressure with the fingertips to make the bristles flex slightly. Feather the touch-up into the scratch using as small an amount as possible. USE OF AEROSOL PAINT IS NOT RECOMMENDED.

Scratches or gouges that expose the metallic substrate:

1. Clean the locale of all dirt, oil, grease or other foreign matter (see CLEANING AND CARE for appropriate cleaning solutions).
2. Sand the damaged area with Scotch-Brite pads
3. Dampen a lint free cloth or tack cloth with acetone using the proper precautions for handling solvents as instructed on the MSDS or container of the solvent. This may include safety glasses, gloves, protective clothing and a respirator. Wipe the surface liberally to clean the areas to the touched up. The surface must be dry before the touch-up coat is applied. Before you use the paint, read the instruction on the container carefully.
4. Apply a quality epoxy or urethane primer to the area to be touched up. Allow to cure according to the primer manufacturer's directions.
5. When applying the touch up paint, LESS IS BEST. Apply with as small an applicator as possible. A brush similar to a finger nail polish applicator is best. Dip the brush half the length of the bristles into the paint. Tap the brush against the side of the container but do no wipe against the lip. Hold the handle near the base and apply a light pressure with the fingertips to make the bristles flex slightly. Feather the touch-up into the scratch using as small an amount as possible. USE OF AEROSOL PAINT IS NOT RECOMMENDED.

PRECAUTION; DO NOT USE TOUCH-UP PAINT OVER BROAD AREAS. TOUCH-UP PAINTS WILL NOT HAVE THE SAME COLOR RETENTION CAPABILITES AS THE THERMALLY CURED FACTORY APPLIED COATING. LONG TERM DIFFERENTIAL FADING BETWEEN THE TWO COATINGS WILL BE MUCH MORE APPARENT IF THE TOUCH-UP PAINT IS NOT APPLIED PROPERLY. FOLLOW MANUFACTURER OF TOUCH-UP PAINT DIRECTIONS FOR APPLICATION INSTRUCTIONS. THERE IS NO GUARANTEE OF PERFORMANCE FOR TOUCH-UP PAINTS

Field Painting / Major Repair of Finish

Warning: *Repainting/Field Painting shall void the Manufacturers Panel Finish Warranty*

On the occasion where a building or home owner chooses to field paint their metal roof or wall panels, use the following guidelines:

1. Lightly scuff sand the finish with Scotch-Brite pads.
2. Power-wash the surface to be painted with a 5% solution in water of commonly used commercial (non-industrial, non-bleach) detergents to remove protective wax as well as dust, dirt and grease. Pressure should not exceed 2,000 PSI. Rinse thoroughly after cleaning and allow to dry.
3. Acrylic Latex exterior paint is preferred to oil based paint. Apply according to manufacturer's instructions. If the original finish is compromised and the metallic substrate is exposed, then a quality epoxy or urethane primer must be applied before the color finish coat. Apply according to manufacturer's instructions. The following paints have been tested and are recommended if available but any high quality Exterior Latex should be acceptable.

Valspar Enterprise or Colony Acrylic Latex Semi-Gloss (Lowe's)
Sears Acrylic Latex Semi-Gloss
Sherwin/Williams Acrylic Latex Semi-Gloss

4. High quality oil base paints may be used only if they contain mineral spirits. Do not use any paint designated "rust inhibitive". Paints of this type may cause the baked-on finish to peel.
5. Do not paint in direct sunlight or when part surface is warm to the touch. Lap marks will result. Brush application is recommended.
6. Spray painting of solvent type paints is not recommended as it may soften the factory finish and cause peeling. If solvent type paint must be spray applied, it should be thinned with VM&P Naphtha also called Lite Naphtha, Dry Cleaners Naphtha or Spotting Naphtha. The following thinners should not be used:

Xylene (Xylol)
Turpentine
MEK (Methyl Ethyl Ketone)
MIBK (Methyl Isobutyl Ketone)
MIAK (Methyl Iso-Amyl Ketone)
DBK (Disobutyl Ketone)
Toluene (Toluol)
Lacquer Thinner

****WARNING: REPAINTING/FIELD PAINTING SHALL VOID THE MANUFACTURERS PANEL FINISH WARRANTY. NCI MAKES NO GUARANTEES REGARDING THE GUIDELINES ABOVE AND SHALL NOT WARRANT ANY FIELD APPLIED COATING OR WHERE RECOATING HAS OCCURRED.****

PROJECT DOCUMENTS

For your convenience and use the following documents are provided for all buildings when applicable. These documents should be kept in a safe location along with other items related to the building, such as architectural drawings and information on building equipment. We recommend making additional copies of pertinent documents and storing them separately in case one set is lost or damaged.

Experience has shown that sooner or later these documents will be needed. They are invaluable in making repairs and modifications, and should you ever decide to sell the building, the documentation can be an important selling tool.

1. Letter of Engineering Design Certification
The letter of certification will include information concerning the building code used in the engineering design of the structure, the design loads, the building size and any special load conditions
2. Erection Drawings
These drawings show the structural, enclosure and trim components of the building. The architectural drawing does **NOT** always contain all of these details. The job number appears in the lower right corner of all pages.
3. Parts and Packing List
This is several pages long and contains the bill of materials for every piece and part shipped to you with your building order. It describes each part in detail, including its color, finish, length and quantity shipped.
4. Warranties (if applicable)
When applicable a written warranty is provided.
5. Product Certifications
Underwriters Laboratories Listings (if applicable)
Certifications from insurers, test labs or independent certification agencies



Descriptions and specifications contained herein were in effect at the time this publication was approved for printing. In a continuing effort to refine and improve products, MBCI reserves the right to discontinue products at any time or change specifications and/or designs without incurring obligation. To ensure you have the latest information available, please inquire or visit our website at mbci.com. Application details are for illustration purposes only and may not be appropriate for all environmental conditions, building designs or panel profiles. Projects should be designed to conform to applicable building codes, regulations and accepted industry practices. If there is a conflict between this manual and project erection drawings, the erection drawings will take precedence.

For current information, visit our website at mbci.com