

Construction No. 244

Wind-Uplift-Class 90 or 30 (See Item 2)

Fire not investigated

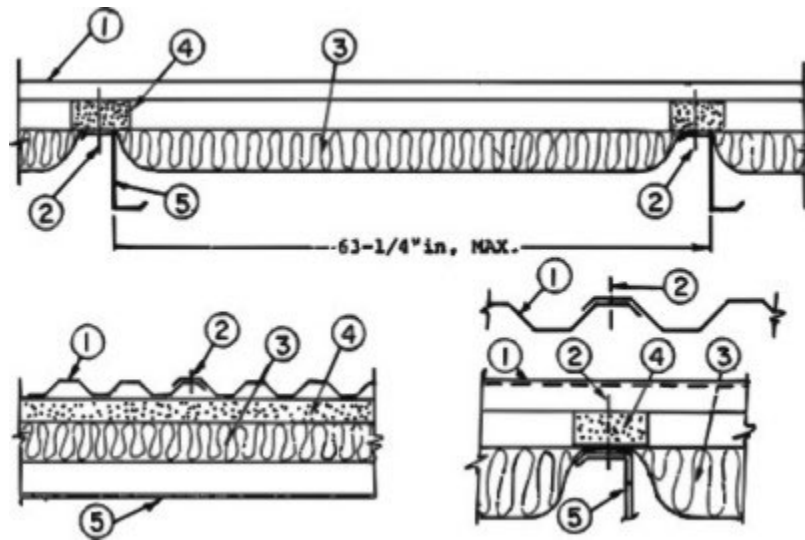

1. Metal Roof Deck Panels* No. 26 MSG min gauge coated steel. Panel 36 in. wide and 1-1/2 in. high at the rib. Panels continuous over two or more spans. End laps to occur over purlins with panels overlapped a min of 4 in. with lap centered over purlin web. A bead of sealant may be used at panel end and side laps.

- MBCI - "7.2 Panel"
- NCI BUILDING SYSTEMS L.P. -"7.2 Panel"

2. Panel Fasteners For panel to purlin attachment, to be No. 12-14 self-drilling, self-tapping, hex-head, plated steel, stand-off screws with a separate 5/8 in. OD formed steel washer and a neoprene sealing washer. Length to be 3-3/4 in. when 2 in. thick thermal spacers (Item 4) and compressible blanked insulation (Item 3) and used and 2-3/8 in. when 1 in. thick thermal spacers are compressible insulation are used. When no thermal spacers are used No. 14.4 by 3/4 in. long self-tapping, hex-head, plated steel screws with 5/8 in. OD formed steel washer and a neoprene sealing washer to be used.

Spacing: For Class 90 to be approximately 7.2 in. O.C. in every valley. For Class 30 to be approximately 14 in. O.C. in every other valley. Spacing for Class 90 or 30 at end-laps to be 7.2 in. O.C./coated in every valley. Fasteners for panel to panel connections to be No. 12-14 by 1 in. long self-drilling, self-tapping, hex-head plated steel screws with a separate 1/2 in. OD formed steel washer and a neoprene sealing washer. Spacing for Class 90 or 30 to be 20 in. O.C. with a fastener located at end lap location in line with purlin fasteners.

3. Insulation - (Optional) Any compressible blanket insulation 4 in. max thickness before compression.

4. Thermal Spacer Block - (Optional) Extruded polystyrene. Continuous max 2 in. thick by 4 in. in width. Installed along top flange of purlin between roof panels and blanket insulation.

5. Purlin - No. 16 MSG min gauge steel.

6. Lateral Bracing - (Not Shown) As required.

Refer to General Information, Roof Deck Constructions (Roofing Materials and Systems Directory) for items not evaluated.

*Bearing the UL Classification Marking