



NuWALL®

Technical/Installation Information

IMPORTANT NOTICE

READ THIS MANUAL COMPLETELY PRIOR TO BEGINNING THE INSTALLATION OF THE NuWALL® ROOFING SYSTEM. MBCI DETAILS MUST BE FOLLOWED AS A MINIMUM TO INSURE APPROPRIATE WARRANTIES WILL BE ISSUED.

ALWAYS INSPECT EACH AND EVERY PANEL AND ALL ACCESSORIES BEFORE INSTALLATION. NEVER INSTALL ANY PRODUCT IF ITS QUALITY IS IN QUESTION. NOTIFY MBCI IMMEDIATELY IF ANY PRODUCT IS BELIEVED TO BE OUT OF TOLERANCE, SPECIFICATION OR HAS BEEN DAMAGED DURING SHIPMENT.

IF THERE IS A CONFLICT BETWEEN PROJECT ERECTION DRAWINGS PROVIDED OR APPROVED BY MBCI AND DETAILS IN THIS MANUAL, PROJECT ERECTION DRAWINGS WILL TAKE PRECEDENCE.

©Copyright NCI Group, Inc. 2018 All Rights Reserved

The Engineering date contained herein is for the expressed use of customers and design professionals. Along with this data, it is recommended that the design professional have a copy of the most current version of the North American Specification for the Design of Cold-Formed Steel Structural Members published by the American Iron and steel Institute to facilitate design. This Specification contains the design criteria for cold-formed steel components. Along with the Specification, the designer should reference the most current building code applicable to the project jobsite in order to determine environmental loads. If further information or guidance regarding cold-formed design practices is desired, please contact the manufacturer.

Descriptions and specifications contained herein were in effect at the time this publication was approved for printing. In a continuing effort to refine and improve products, MBCI reserves the right to discontinue products at any time or change specifications and/or designs without incurring obligation. **To insure you have the latest information available, please inquire or visit our Web Site at <http://www.mbc.com>.** Application details are for illustration purposes only and may not be appropriate for all environmental conditions, building designs, or panel profiles. Projects should be designed to conform to applicable building codes, regulations, and accepted industry practices. If there is a conflict between this manual and project erections drawings, the erection drawings will take precedence.

TABLE OF CONTENTS

ROOFING SYSTEM

General Description..... NW-2
Architect/Engineer Information NW-3

SPECIFICATIONS

Specifications For Metal Roofing NW-4-8

GENERAL INFORMATION

Product Checklist NW-9
Installation Guidelines NW-10

DESIGN

Typical Details/Retrofit
Panel Attachment NW-11
Wall Cap NW-12
Window/Door Head NW-13
Window/Door Jamb NW-14
Window Sill NW-15
Outside Corner NW-16
Inside Corner NW-17
Base NW-18

Typical Details/New Construction
Panel Attachment NW-19
Door Head/Jamb NW-20
Window Head/Sill NW-21
Window Jamb NW-20
Outside Corner NW-22
Inside Corner NW-23
Base NW-24

PRODUCT INFORMATION

GENERAL DESCRIPTION

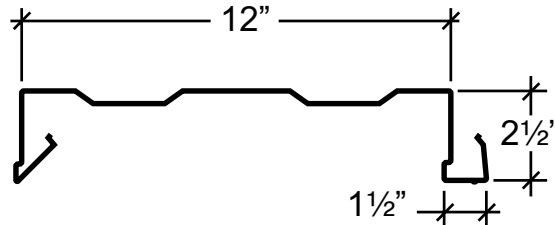

Coverage Width - 12"

Panel Attachment - See page NW-10

Panel Substrate - Galvalume®

Panel Finish - Smooth or Embossed

Gauge - 24 & 22

PRODUCT SELECTION CHART

	Galvalume®	Signature 300*	Signature 300*	Signature 200*
24 gauge	●	■	■	■
22 gauge	■	■	■	■

*See architectural color chart for available colors.

- - Available in any quantity
- - Minimum quantity may be required.

NOTICE
 Contact MBCI for Positive and Negative Wind Load information.

PRODUCT INFORMATION

ARCHITECT/ENGINEER INFORMATION

1. **NuWall®** is a concealed fastener wall panel designed to be used as either a retrofit wall panel or in new construction. The **NuWall®** system is based on a 12" module. This means that when using **NuWall®** over existing metal panels, the existing panel ribs must be 6" or 12" on center.
2. Wall girts to which the **NuWall®** panels are to be attached must be properly aligned to prevent oil canning of the panels.
3. Heavier gauges and embossing minimizes oil canning. Industry standard - 24 gauge material. Oil canning is not a cause for rejection.
4. For continuous runs over 40', please inquire.
5. For retrofit construction, a layer of 2" blanket insulation may be added between the existing panels and the **NuWall®** panels.
6. Caution for new construction - the **NuWall®** panel does not provide diaphragm capabilities.

SPECIFICATIONS

SECTION 07 42 13.13 FORMED METAL WALL PANELS

Specifier: Notation (#) means that text following is a specifier's note or sample.

PART 1 - GENERAL

1.01 SECTION INCLUDES

- A. Consealed fastener, lap-seam metal wall panels, with related metal trim and accessories [installed over existing metal panel wall system].

1.02 RELATED REQUIREMENTS

Specifier: If retaining this optional article, edit list below to correspond to Project.

- A. **Division 01 Section "Sustainable Design Requirements"** for related LEED general requirements.
- B. **Division 05 Section "Structural Steel Framing"** for steel framing supporting metal panels.
- C. **Division 05 Section "Cold-Formed Metal Framing"** for cold-formed metal framing supporting metal panels.
- D. **Division 07 Section "Thermal Insulation"** for thermal insulation installed under metal panels.
- E. **Division 07 Section "Air Barriers"** for air barriers within wall assembly and adjacent to wall assembly.
- F. **Division 07 Section "Metal Soffit and Wall Liner Panels"** for soffit and wall liner panels installed with metal wall panels.
- G. **Division 07 Section "Sheet Metal Flashing and Trim"** for sheet metal flashing items in addition to items specified in this Section.
- H. **Division 13 Section "Metal Building Systems"** for steel framing supporting metal panels.

1.03 REFERENCES

Specifier: If retaining this optional article, edit list below to correspond to Project.

- A. **American Architectural Manufacture's Association (AAMA): www.aamanet.org:**
 - 1. AAMA 621 - Voluntary Specifications for High Performance Organic Coatings on Coil Coated Architectural Hot Dipped Galvanized (HDG) & Zinc-Aluminum Coated Steel Substrates.
 - 2. AAMA 809.2 Voluntary Specification Non-Drying Sealants.

- B. **American Society of Civil Engineers (ASCE):**

www.asce.org/codes-standards:

- 1. ASCE 7 - Minimum Design Loads for Buildings and Other Structures.

- C. **ASTM International (ASTM): www.astm.org:**

- 1. ASTM A755 - Specification for Steel Sheet, Metallic Coated by the Hot-Dip Process and Prepainted by the Coil-Coating Process for Exterior Exposed Building Products.
- 2. ASTM A792/A 792M - Standard Specification for Steel Sheet, 55% Aluminum-Zinc Alloy-Coated by the Hot-Dip Process.
- 3. ASTM C920 - Specification for Elastomeric Joint Sealants.
- 4. ASTM D2244 - Test Method for Calculation of Color Differences from Instrumentally Measured Color Coordinates.
- 5. ASTM D4214 - Test Methods for Evaluating Degree of Chalking of Exterior Paint Films.
- 6. ASTM E1592 - Standard Test Method for Structural Performance of Sheet Metal Roof and Siding Systems by Uniform Static Air Pressure Difference.

- D. **International Accreditation Service (IAS):**

- 1. IAS AC 472 Accreditation Criteria for Inspection Programs for Manufacturers of Metal Building Systems, Part B.

- E. **US Green Building Council (USGBC):**

www.usgbc.org:

- 1. Leadership in Energy and Environmental Design (LEED) Green Building Rating System.

1.04 QUALITY ASSURANCE

- A.. **Manufacturer/Source:** Provide metal panel assemblies and accessories from a single manufacturer accredited under IAS AC472, Part B.
- B. **Manufacturer Qualifications:** Approved manufacturer listed in this Section with minimum five years experience in manufacture of similar products in successful use in similar applications.

Specifier: Retain paragraph below if Owner allows substitutions but requires strict control over qualifying of substituted manufacturers.

- 1. Approval of Comparable Products: Submit the following in accordance with project substitution requirements, within time allowed for substitution review:

NOTICE

Contact MBCI for the proper combination of panel gauge, clip type, clip spacing and substructure to achieve a UL 90 rated system.

SPECIFICATIONS

- a. Product data, including certified independent test data indicating compliance with requirements.
 - b. Samples of each component.
 - c. Sample submittal from similar project.
 - d. Project references: Minimum of five installations not less than five years old, with Owner and Architect contact information.
 - e. Sample warranty.
 - f. Certificate of accreditation under IAS AC472 Part B
2. Substitutions following award of contract are not allowed except as stipulated in Division 01 General Requirements.
 3. Approved manufacturers must meet separate requirements of Submittals Article.

Specifier: Review of manufacturers' qualifying of installers is recommended. MBCI requires Installer and supervisor certification when project requirements include extended warranty.

C. Installer Qualifications: Experienced Installer [certified by metal panel manufacturer] with minimum of five years experience with successfully completed projects of a similar nature and scope.

1. Installer's Field Supervisor: Experienced mechanic [certified by metal panel manufacturer] supervising work on site whenever work is underway.

Specifier: Retain paragraph below and edit as appropriate for Federal projects and for public works projects utilizing Federal funds; consult with project Contracting Officer. Coordinate with Submittals Article.

D. Buy American Compliance: Materials provided under work of this Section shall comply with the following requirements:

1. Buy American Act of 1933 BAA-41 U.S.C §§ 10a - 10d.
2. Buy American provisions of Section 1605 of the American Recovery and Reinvestment Act of 2009 (ARRA).

E. Steel Construction Publications: Comply with published recommendations in the following, unless more stringent requirements are indicated.

1. American Institute of Steel Construction (AISC): "Steel Construction Manual."
2. American Iron and Steel Institute (AISI): "Cold Formed Steel Design Manual."

1.05 ADMINISTRATIVE REQUIREMENTS

A.. Preinstallation Meeting: Prior to erection of framing, conduct preinstallation meeting at site attended by Owner, Architect, metal panel installer, metal panel manufacturer's technical representative, inspection agency and related trade contractors.

1. Coordinate building framing in relation to metal panel system.

2. Coordinate openings and penetrations of metal panel system.
3. Coordinate work of Division 07 Sections "Roof Specialties" and "Roof Accessories" and openings and penetrations and manufacturer's accessories with installation of metal panels.

1.06 ACTION SUBMITTALS

A. Product Data: Manufacturer's data sheets for specified products. Include data indicating compliance with performance requirements.

Specifier: Retain and edit below to comply with Project requirements for LEED or other sustainable design requirements.

B. LEED Submittals:

1. Credit MR 4 Recycled Content: Product data indicating the following:
 - a. Material costs for each product having recycled content.
 - b. Percentages by weight of post-consumer and pre-consumer recycled content for each item.
 - c. Total weight of products provided.
2. Credit IEQ 4.1 Low-Emitting Materials - Adhesives and Sealants: Product data for sealants and sealant primers used inside the weatherproofing system, indicating VOC content.

C. Shop Drawings: Show layouts of metal panels. Include details of each condition of installation, panel profiles, and attachment to building. Provide details at a minimum scale 1-1/2 inch per foot of edge conditions, joints, fastener and sealant placement, flashings, openings, penetrations, and special details. Make distinctions between factory and field assembled work.

1. Indicate points of supporting structure that must coordinate with metal panel system installation.
2. Include structural data indicating compliance with performance requirements and requirements of local authorities having jurisdiction.

D. Samples for Initial Selection: For each exposed product specified including sealants. Provide representative color charts of manufacturer's full range of colors.

E. Samples for Verification: Provide 12-inch-(305 mm-) long section of each metal panel profile. Provide color chip verifying color selection.

1.07 INFORMATIONAL SUBMITTALS

- A. **Product Test Reports:** Indicating compliance of products with requirements.
- B. **Qualification Information:** For installer firm and Installer's field supervisor.
- C. **IAS Accreditation Certificate:** Indicating that manufacturer is accredited under provisions of IAS AC472 Part B.

SPECIFICATIONS

- D. **Buy American Certification:** Manufacturers' letters of compliance acceptable to authorities having jurisdiction, indicating that products comply with requirements.
- E. **Manufacturer's Warranty:** Unexecuted sample copy of manufacturer's warranty.

1.08 CLOSEOUT SUBMITTALS

- A. **Maintenance data.**
- B. **Manufacturer's Warranty:** Executed copy of manufacturer's warranty.

1.09 DELIVERY, STORAGE, AND HANDLING

- A. **Protect products of metal panel system during shipping, handling, and storage to prevent staining, denting, deterioration of components or other damage. Protect panels and trim bundles during shipping.**
 - 1. Deliver, unload, store and erect metal panels and accessory items without misshaping panels or exposing panels to surface damage from weather or construction operations.
 - 2. Store in accordance with Manufacturer's written instruction. Provide wood collars for stacking and handling in the field.
 - 3. Shield foam insulated metal panels from direct sunlight until installation.

1.10 WARRANTY

Specifier: Warranty terms below are available from MBCI. Verify that other allowable manufacturers furnish warranty meeting requirements.

- A. **Special Manufacturer's Warranty:** On manufacturer's standard form, in which manufacturer agrees to repair or replace metal panel assemblies that fail in materials and workmanship within [one] year from date of Substantial Completion.
- B. **Special Panel Finish Warranty:** On Manufacturer's standard form, in which Manufacturer agrees to repair or replace metal panels that evidence deterioration of factory-applied finish within the warranty period, as follows:

Specifier: Retain finish warranty paragraph that corresponds to selected metal panel finish system. Several exotic and metallic colors are available from MBCI with limited warranty periods; verify warranty period for selected colors with manufacturer.

- 1. **Fluoropolymer Two-Coat System:**
 - a. Basis of Design System: **MBCI, Signature 300.**
 - b. Color fading in excess of 5 Hunter units per ASTM D2244
 - c. Chalking in excess of No. 8 rating per ASTM D4214
 - d. Failure of adhesion, peeling, checking, or cracking.

- e. Warranty Period: [40] years from date of Substantial Completion.
- 2. **Modified Silicone-Polyester Two-Coat System:**
 - a. Basis of Design System: **MBCI, Signature 200.**
 - b. Color fading in excess of 7 Hunter units per ASTM D2244
 - c. Chalking in excess of No. 6 rating per ASTM D4214
 - d. Failure of adhesion, peeling, checking, or cracking.
 - e. Warranty Period: [30] years from date of Substantial Completion.

PART 2 - PRODUCTS

2.01 MANUFACTURER

Specifier: Retain basis of design manufacturer and products listed in this Article where allowed. If inserting comparable manufacturers, carefully review products and engineering capabilities in relation to requirements of this Section, to ensure that other approved manufacturers offer products meeting MBCI's standards.

- A. **Basis of design Manufacturer:** **MBCI Metal Roof and Wall Systems, Division of NCI Group, Inc.; Houston, TX; Tel: (877) 713-6224; Email: info@mbci.com; Web: www.mbci.com.**

- 1. Provide basis of design product [or comparable product approved by Architect prior to bid].

2.02 PERFORMANCE REQUIREMENTS

- A. **General:** Provide metal panel system meeting performance requirements as determined by application of specified test by a qualified testing facility on manufacturer's standard assemblies.

Specifier: Recycled Content paragraph below describes calculation utilized for LEED-NC Credit MR 4. Modify as required to meet project recycled content requirements, or delete if recycled content requirements are stipulated solely in Division 01 Section "Sustainable Design Requirements."

- B. **Recycled content: For Steel Products:** Postconsumer recycled content plus one-half of preconsumer recycled content not less than [25] percent.
- C. **Structural Performance:** Provide metal panel assemblies capable of withstanding the effects of indicated loads and stresses within limits and under conditions indicated, as determined by ASTM E1592:

Specifier: Consult structural engineer and edit below as required by local codes. Insert structural data below if not indicated on drawings. Select applicable deflection limit.

- 1. **Wind Loads:** Determine loads based on uniform pressure, importance factor, exposure category, and basic wind speed indicated on drawings.

SPECIFICATIONS

- a. Wind Negative Pressure: Certify capacity of metal panels by actual testing of proposed assembly.
2. Deflection Limits: Withstand inward and outward wind-load design pressures in accordance with applicable building code with maximum deflection of 1/120 of the span with no evidence of failure.
3. Seismic Performance: Comply with ASCE 7 Sections 9, "Earthquake Loads."
- D. Thermal Movements: Allow for thermal movements from variations in both ambient and internal temperatures. Accommodate movement of support structure caused by thermal expansion and contraction. Allow for deflection and design for thermal stresses caused by temperature differences from one side of the panel to the other.

2.03 FORMED METAL WALL PANELS

- A. **Flush-Profile, Concealed Fastener Metal Wall Panels: Structural metal panels consisting of formed metal sheet with vertical panel edges and two 1/2 inch (12 mm) tapered inverted intermediate ribs, with flush joints between panels, field assembled with nested snap-fit lapped edges, and attached to supports using concealed fasteners.**

1. Basis of Design: **MBCI, NuWall.**

Specifier: Material description below corresponds to BIEC International, Inc. <http://galvalume.com> Galvalume substrate, available Prepainted from MBCI.

Second paragraph below describes Galvalume Plus with clear acrylic coating for use as exposed metallic finish.

2. Aluminum-Zinc Alloy-Coated Steel Sheet: ASTM A792/A792M, structural quality, Grade 50, Coating Class AZ50 (Grade 340, Coating Class AZM150), prepainted by the coil-coating process per ASTM A755/A755M.

Specifier: Prior to selecting metal thickness and panel thickness below, consult manufacturer's span tables and review selection against panel thickness requirements and span condition. Select appropriate panel configuration to meet requirements of design wind pressure. **Important: Consult this document when specifying gauge with the intent that it meet a prescriptive decimal thickness requirement in addition to strength performance requirements.**

- a. Nominal Thickness: [24 gauge] [22 gauge] coated thickness, with [smooth] [stucco embossed] surface.
 - 1) Exterior Finish: [Modified silicone-polyester two-coat system] [Fluoropolymer two-coat metallic color system] [Exposed Galvalume Plus coating].
 - 2) Color: [As indicated] [As selected by Architect from manufacturer's standard colors] [Match Architect's custom color].
3. Panel Width: 12 inches (305 mm).
4. Panel Thickness: 2-1/2 inches (76 mm).

2.04 MISCELLANEOUS MATERIALS

- A. **General: Provide complete metal panel assemblies incorporating trim, copings, fasciae, gutters and downspouts, and miscellaneous flashings. Provide required fasteners, closure strips, and sealants as indicated in manufacturer's written instructions.**
- B. **Flashing and Trim: Match material, thickness, and finish of metal panels.**
- C. **Panel Fasteners: Self-tapping screws and other acceptable fasteners recommended by metal panel manufacturer. Where exposed fasteners cannot be avoided, supply corrosion-resistant fasteners with heads matching color of metal panels by means of factory-applied coating, with weather-tight resilient washers.**
- D. **Panel Sealants:**
 1. VOC Content of Interior Sealants: Sealants used inside the weatherproofing system shall comply with the following limits for VOC content when calculated according to 40 CFR 59, Subpart D (EPA Method 24):
 - a. Architectural Sealants: 250 g/L.

2.05 FABRICATION

- A. **General: Provide factory fabricated and finished metal panels, trim and accessories meeting performance requirements, indicated profiles and structural requirements.**
- B. **Sheet Metal Flashing and Trim: Fabricate flashing and trim to comply with manufacturer's written instructions, approved shop drawings, and project drawings.**

2.06 FINISHES

- A. **Finishes, General: Prepare, pretreat and apply coating to exposed metal surfaces to comply with coating and resin manufacturers' written instructions.**
- B. **Modified Silicone-Polyester Two-Coat System: 0.20 - 0.25 mil primer with 0.7 - 0.8 mil color coat [meeting solar reflectance index requirements].**
 1. Basis of Design: **MBCI, Signature 200.**

Specifier: MBCI's fluoropolymer coatings are based on Arkema, Inc. Kynar 500 and Solvay Solexis Hylar 500 PVF2 resins

- C. **Fluoropolymer Two-Coat System: 0.2 - 0.3 mil primer with 0.7 - 0.8 mil 70 percent PVDF fluoropolymer color coat, AAMA 621 [meeting solar reflectance index requirements].**
 1. Basis of Design: **MBCI, Signature 300.**

SPECIFICATIONS

PART 3 - EXECUTION

3.01 EXAMINATION

A. **Examination metal panel system substrate with Installer present. Inspect for erection tolerances and other conditions that would adversely affect installation of metal panels.**

1. Inspect framing that will support insulated metal panels to determine if support components are installed as indicated on approved shop drawings and are within tolerances acceptable to metal panel manufacturer and installer. Confirm presence of acceptable framing members at recommended spacing to match installation requirements of metal panels.

B. **Correct out-of-tolerance work and other deficient conditions prior to proceeding with insulated metal panel installation.**

3.02 METAL PANEL INSTALLATION

A. **Concealed-Fastener Formed Metal Panels: Install metal panel system in accordance with manufacturer's written instructions, approved shop drawings, project drawings and referenced publications. Install metal panels in orientation, sizes and locations indicated. Anchor panels and other components securely in place. Provide for thermal and structural movement.**

B. **Fasten metal panels to supports with fasteners at each location indicated on approved shop drawings, at spacing and with fasteners recommended by manufacturer. Fasten panel to support structure through leading flange. Snap-fit back flange of subsequent panel into secured flange of previous panel, and fasten panels together through flush-fitted panel sides.**

1. Cut panels in field where required using manufacturer's recommended methods.
2. Provide EPDM weatherproof jacks for pipe and conduit penetrating metal panels.
3. Dissimilar Materials: Where elements of metal panel system will come into contact with dissimilar materials, treat faces and edges in contact with dissimilar materials as recommended by metal panel manufacturer.

C. **Attach panel flashing trim pieces to supports using recommended fasteners and joint sealers.**

3.03 ACCESSORY INSTALLATION

A. **General: Install metal panel accessories with positive anchorage to building and weather tight mounting; provide for thermal expansion. Coordinate installation with flashings and other components.**

1. Install components required for a complete metal panel assembly, including trim, copings, flashings, sealants, closure strips and similar items.

2. Comply with details of assemblies utilized to establish compliance with performance requirements and manufacturer's written installation instructions.
3. Set units true to line and level as indicated. Install work with laps, joints and seams that will be permanently weather resistant.

3.04 CLEANING AND PROTECTION

- A. **Clean finished surfaces as recommended by metal panel manufacturer.**
- B. **Replace damaged panels and accessories that cannot be repaired to the satisfaction of the Architect.**

END OF SECTION

DISCLAIMER: *MBCI makes no warranty, express or implied, as to the merchantability or fitness for any particular purpose of any product manufactured by an optional manufacturer. If you choose to use a product manufactured by an optional manufacturer, as defined herein, you take the product as is and at your own risk. Descriptions and specifications contained herein were in effect at the time this publication was approved for printing. MBCI reserves the right to discontinue products at any time or change specifications and/or designs without notice and without incurring obligation.*

To insure you have the latest information available, please inquire.
DISCLAIMER: *MBCI makes no warranty, express or implied, as to the merchantability or fitness for any particular purpose of any product manufactured by an optional manufacturer. If you choose to use a product manufactured by an optional manufacturer, as defined herein, you take the product as is and at your own risk. Descriptions and specifications contained herein were in effect at the time this publication was approved for printing. MBCI reserves the right to discontinue products at any time or change specifications and/or designs without notice and without incurring obligation.*

To insure you have the latest information available, please inquire.

GENERAL INFORMATION

PRODUCT CHECKLIST

<p>NuWall® Panel</p> <p style="text-align: right;"><input type="checkbox"/></p>	<p>New Construction Base Trim</p> <p style="text-align: right;">T-6210 <input type="checkbox"/></p>	<p>New Construction Head Trim</p> <p style="text-align: right;">T-6234 <input type="checkbox"/></p>
<p>Wall Cap Trim</p> <p>For "R" Panel Only T-6218 <input type="checkbox"/></p>	<p>Retrofit Base Trim</p> <p>For "R" Panel Only T-6214 <input type="checkbox"/></p>	<p>Retrofit Head/Jamb Trim</p> <p style="text-align: right;">T-6228 <input type="checkbox"/></p>
<p>Spacer Angle</p> <p style="text-align: right;">T-6242 <input type="checkbox"/></p>	<p>Outside Corner</p> <p style="text-align: right;">T-5241 <input type="checkbox"/></p>	<p>Inside Corner</p> <p style="text-align: right;">T-5251 <input type="checkbox"/></p>
<p>Spacer Zee</p> <p style="text-align: right;">T-6246 <input type="checkbox"/></p>	<p>Downspout 45° Offset</p> <p>For "R" Panel Only T-6250 <input type="checkbox"/></p>	<p>Head/Jamb Trim</p> <p style="text-align: right;">T-6222 <input type="checkbox"/></p>
<p>Fasteners #17</p> <p style="text-align: right;"><input type="checkbox"/></p>	<p>Fasteners #4</p> <p style="text-align: right;"><input type="checkbox"/></p>	<p>Fasteners #14</p> <p style="text-align: right;"><input type="checkbox"/></p>
<p>Fasteners #4A</p> <p style="text-align: right;"><input type="checkbox"/></p>	<p>Fasteners #14A</p> <p style="text-align: right;"><input type="checkbox"/></p>	<p>Fasteners #14A</p> <p style="text-align: right;"><input type="checkbox"/></p>

GENERAL INFORMATION

INSTALLATION GUIDELINES

- I. Pre-Order
 - A. Prior to ordering panels, all dimensions should be confirmed by field measurements.
- II. Jobsite Storage and Handling
 - A. Check the shipment against the shipping list.
 - B. Damaged material must be noted on Bill of Lading.
 - C. Panels should be handled carefully. A spreader bar of appropriate length is recommended for hoisting.
 - D. Check to see that moisture has not formed inside the bundles during shipment. If moisture is present, panels should be wiped dry, then restacked and loosely covered so that air can circulate between the panels.
- III. Application Checklist
 - A. Check substructure for proper alignment and uniformity to avoid panel distortion.
 - B. Periodic check of panel alignment is crucial to proper panel installation.
 - C. Panels should be cut on the ground to minimize cut filings on roof. Keep panels clean during installation. Do not allow panels to come into contact with or water runoff from lead, copper, or graphite.

DETAILS

TYPICAL DETAILS - RETROFIT PANEL ATTACHMENT

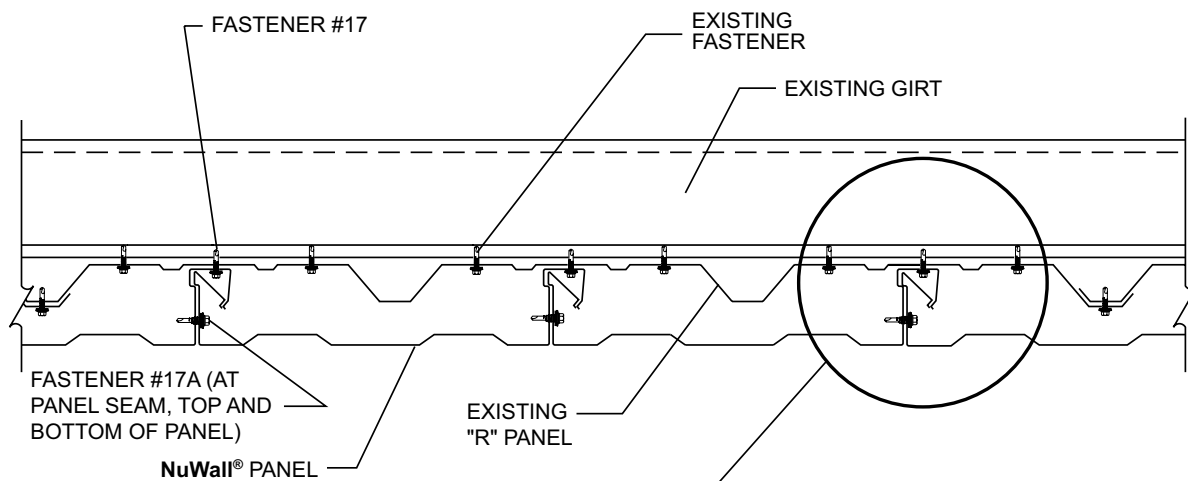

CROSS SECTION OF PANEL ATTACHMENT

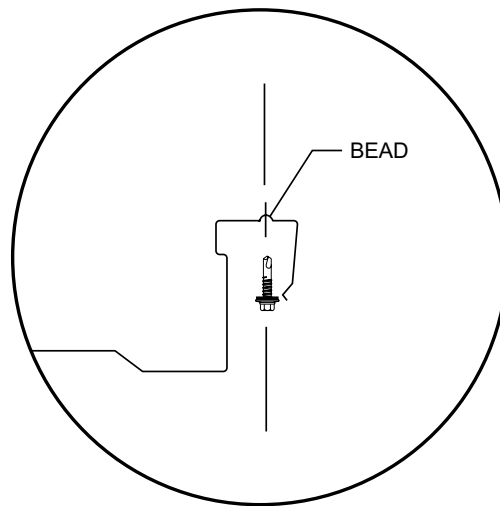
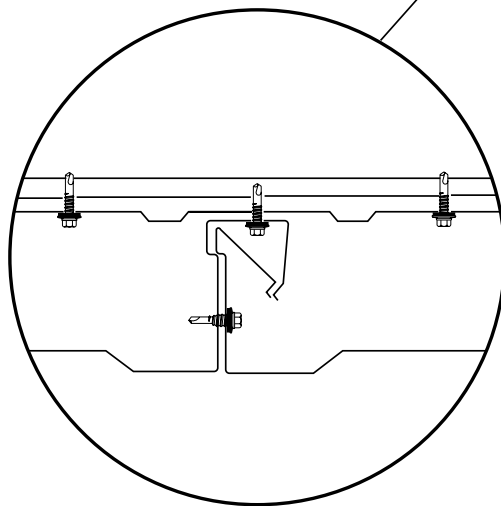

FASTENER LOCATION

NOTES:

1. Existing fasteners that are in the same area as the NuWall® panel rib must be removed. Do not remove sidelap fasteners from existing wall panels.
2. Panels are installed to existing girts with one Fastener #17 at each girt.
3. Install NuWall® fasteners in the bead of the female rib of panel.

DETAILS

TYPICAL DETAILS - RETROFIT WALL CAP

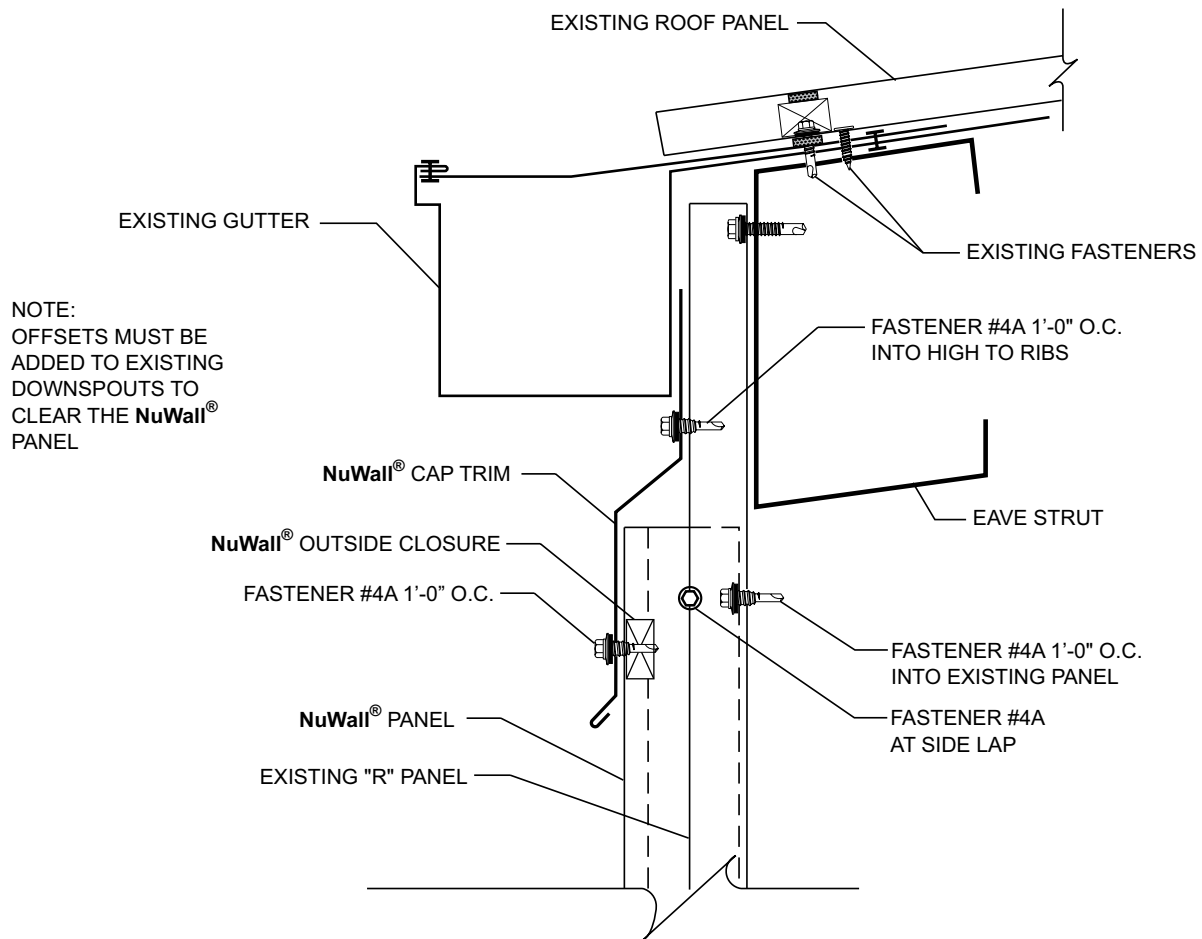

NOTES:

1. After wall panels are installed, slide cap trim under existing gutter or eave trim and attach to panels with Fastener #4 at 12" o.c.
2. Lap cap trim 3" and seal laps with urethane sealant.
3. Offsets must be added to existing downspouts to allow them to clear the NuWall® panel system.

DETAILS

TYPICAL DETAILS - RETROFIT WINDOW/DOOR HEAD

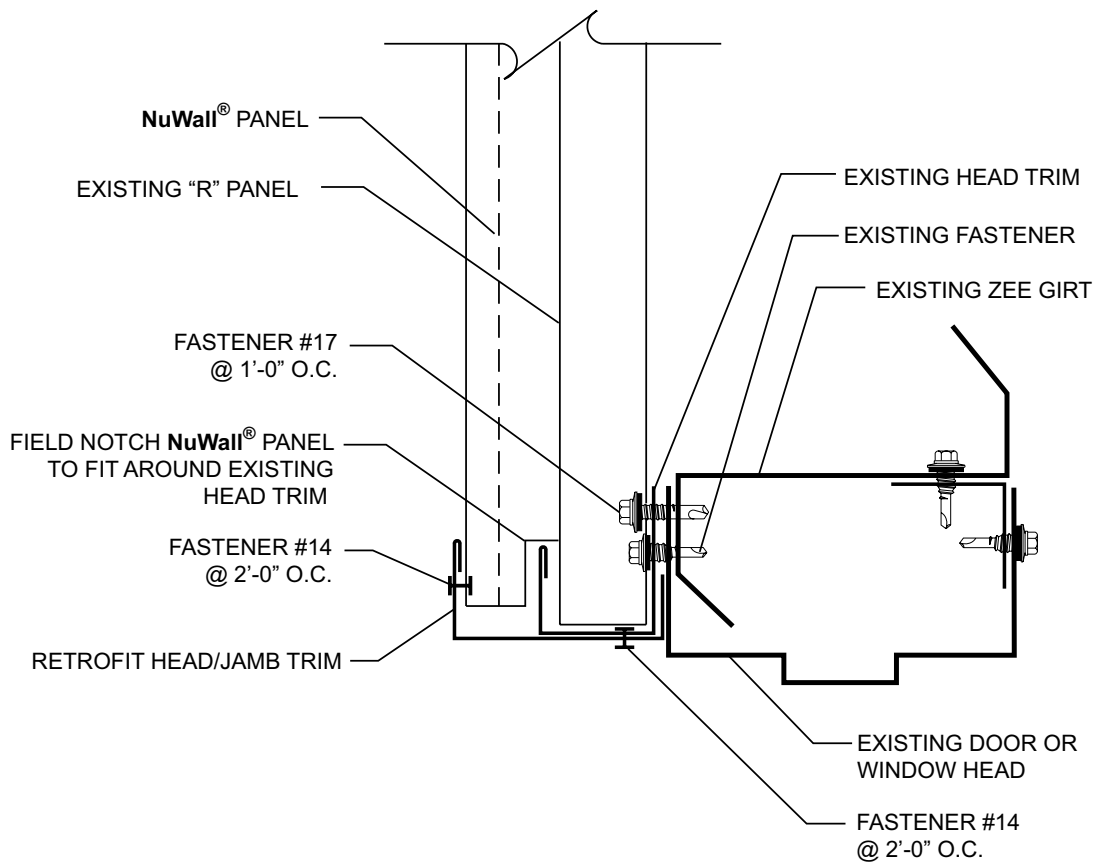

NOTES:

1. Notch NuWall® panels to fit around existing head trim. After panels are installed, slide retrofit Head/Jamb trim over existing head trim and attach with Fastener #14 on bottom leg 2'-0" o.c.

DETAILS

TYPICAL DETAILS - RETROFIT WINDOW/DOOR JAMB

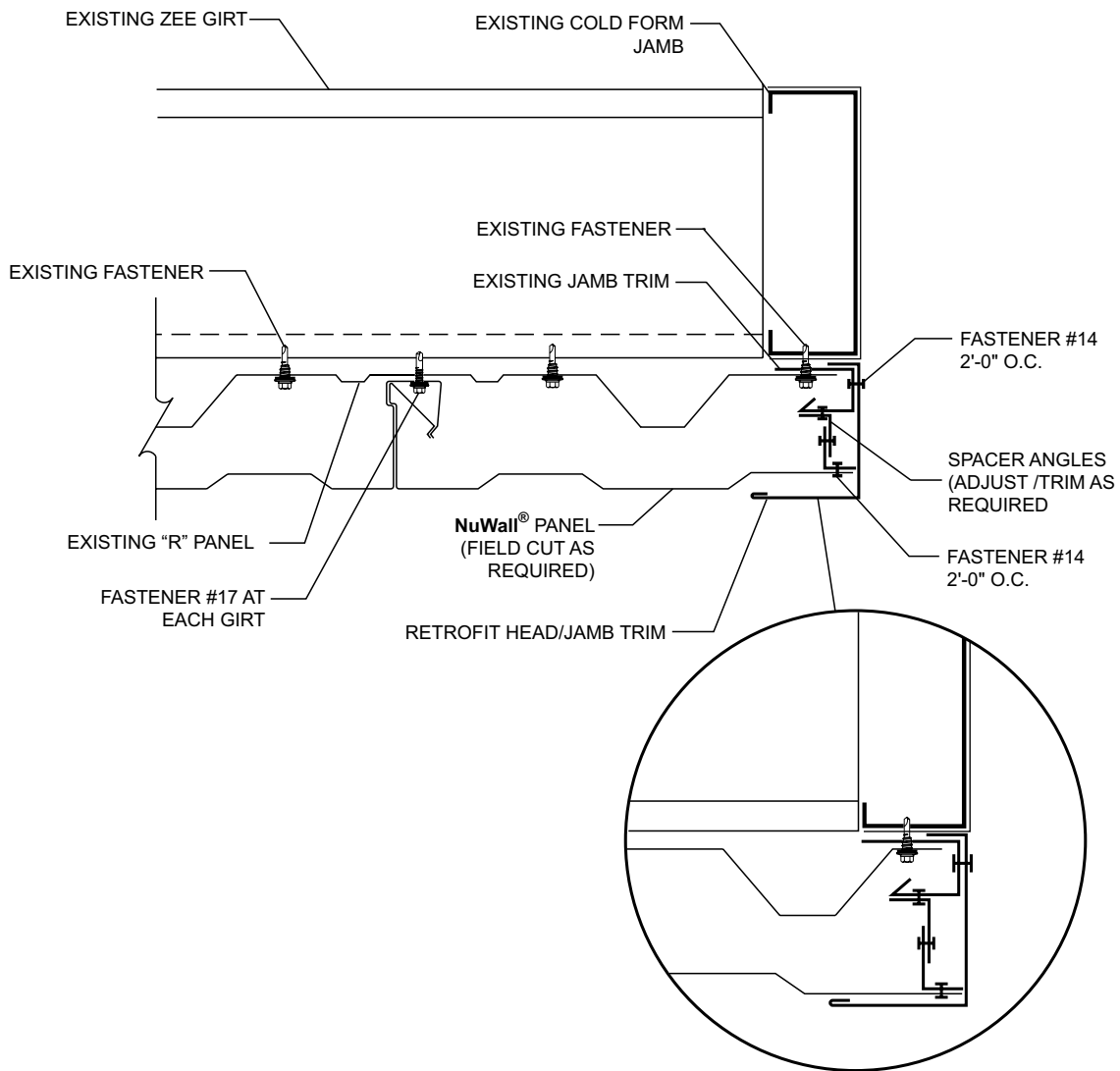

ENDING AT HIGH

NOTES:

1. Secure spacer angles to existing jamb trim with Fastener #14 at 2'-0" o.c.
2. Attach NuWall® panel to spacer angles with Fastener #14 at 2'-0" o.c.
3. Attach retrofit Head/Jamb trim to existing jamb trim with Fastener #14 at 2'-0" o.c.

DETAILS

TYPICAL DETAILS - RETROFIT WINDOW SILL

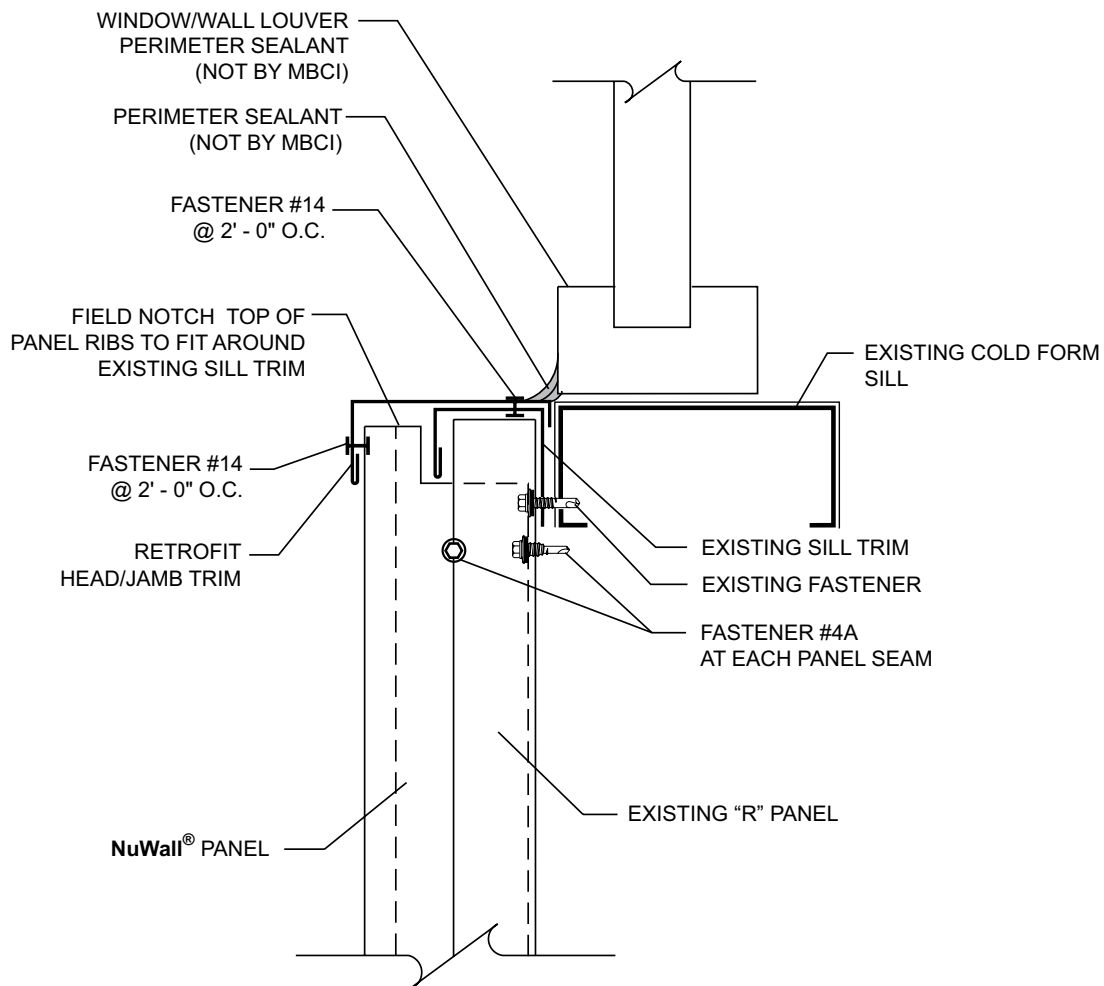

NOTES:

1. Notch NuWall® panels to fit around existing sill trim.
2. After panels are installed, attach retrofit Head/Jamb trim to existing sill trim with Fastener #14 at 2'-0" o.c.
3. Seal to window frame with urethane sealant.

DETAILS

TYPICAL DETAILS - RETROFIT OUTSIDE CORNER

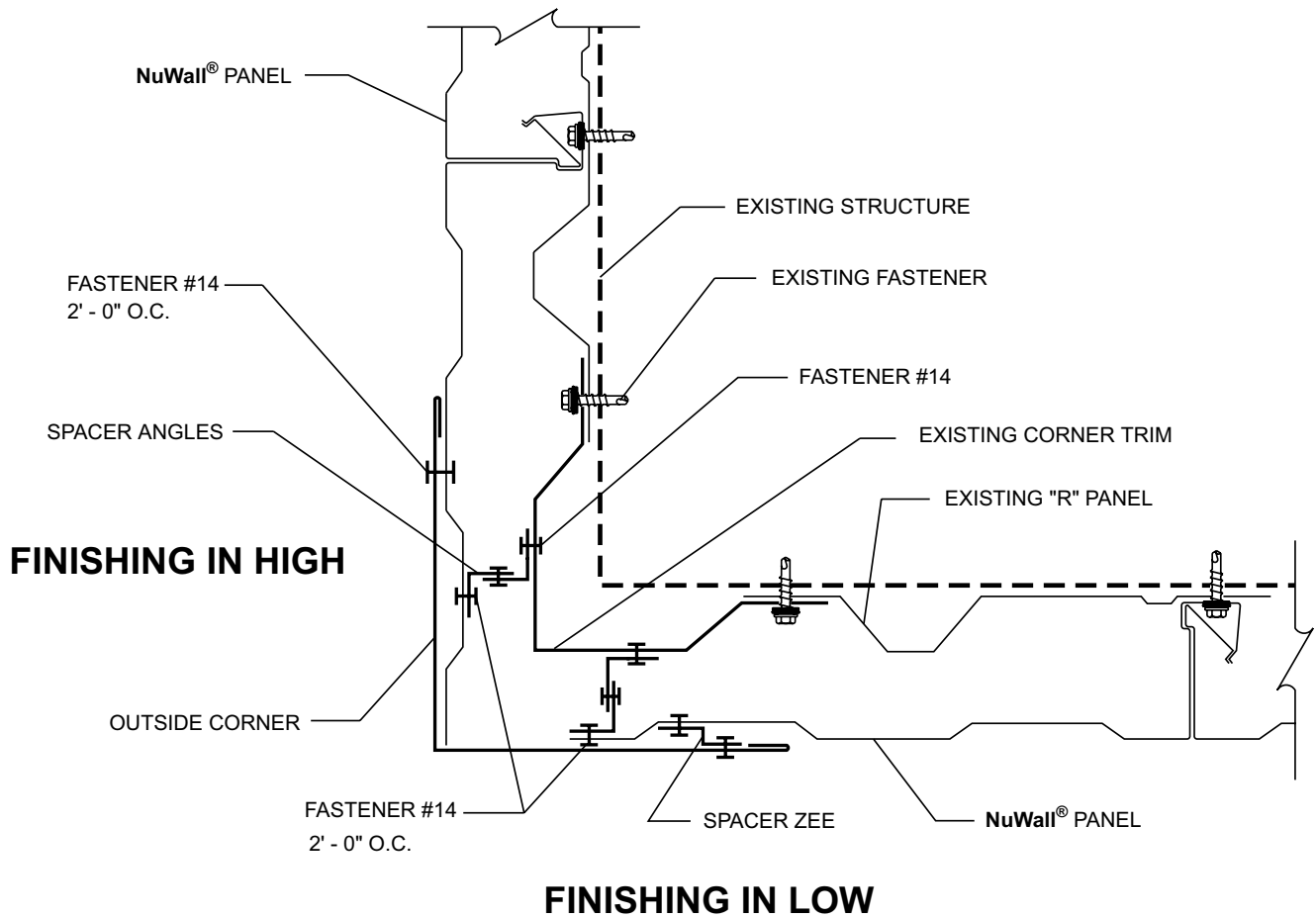

NOTES:

1. Attach spacer angles to existing corner trim with Fastener #14 at 2'-0" o.c.
2. Attach NuWall panel to spacer angles with Fastener #14 at 2'-0" o.c.
3. Attach new outside corner to **NuWall®** with Fastener #14 at 2'-0" o.c.

DETAILS

TYPICAL DETAILS - RETROFIT INSIDE CORNER

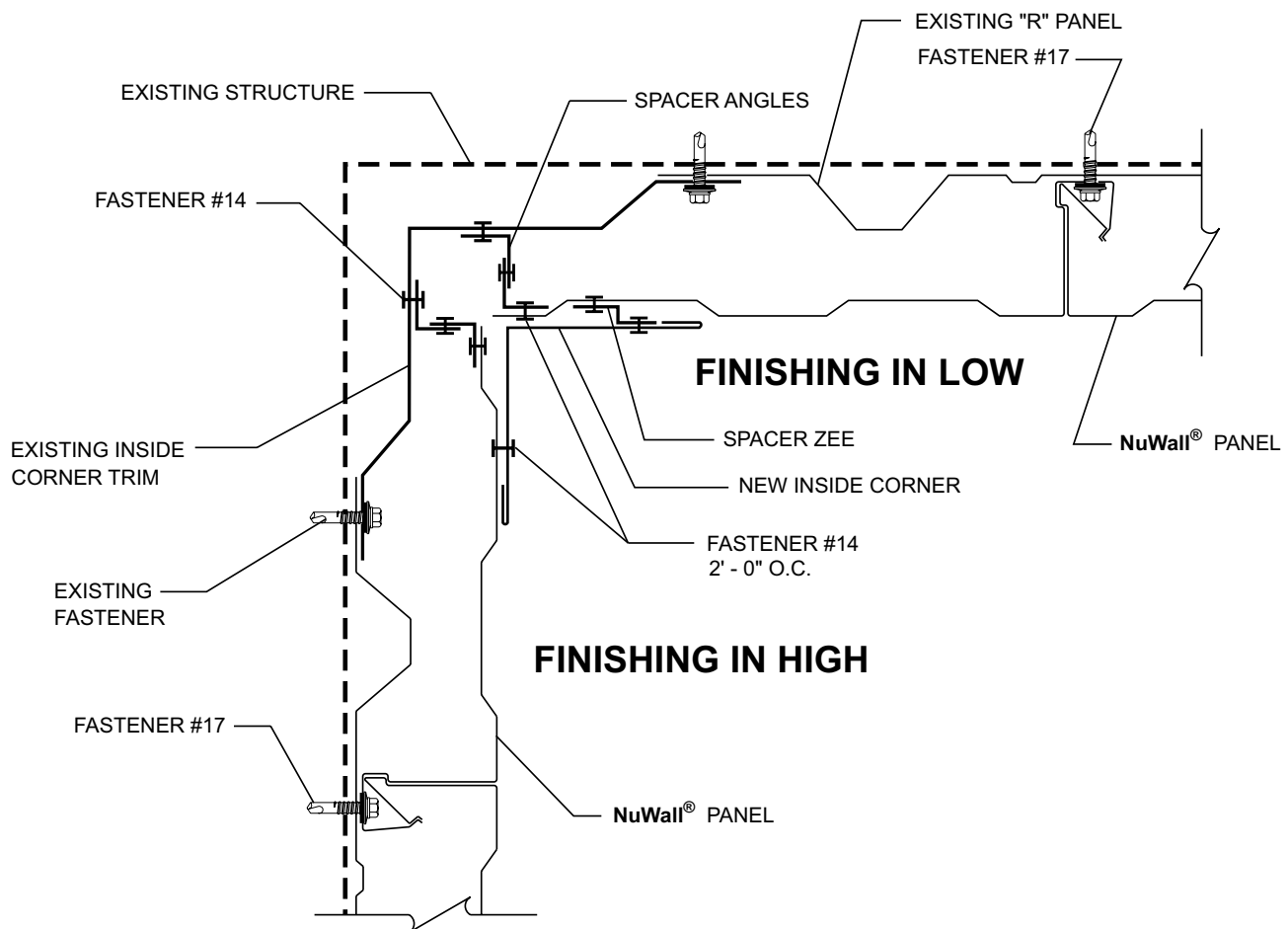

NOTES:

1. Attach spacer angles to existing inside corner with Fastener #14 at 2'-0" o.c.
2. Attach **NuWall®** panel to spacer angles with Fastener #14 at 2'-0" o.c.
3. Attach new inside corner with Fastener #14 at 2'-0" o.c.

DETAILS

TYPICAL DETAILS - RETROFIT BASE

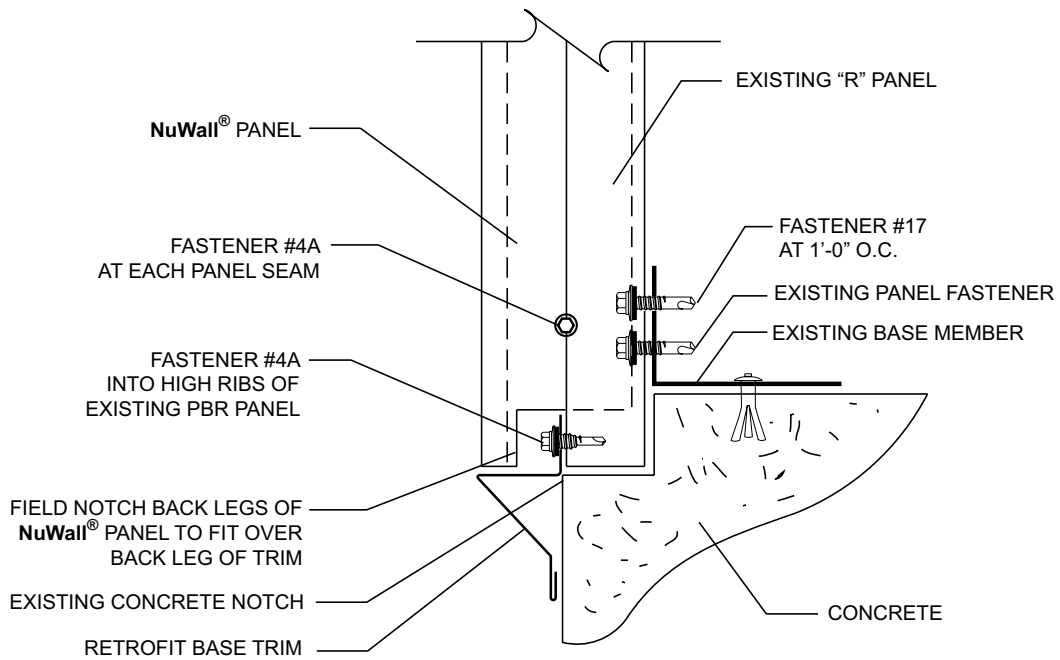

NOTE:

1. Attach retrofit base trim to existing wall panels with a Fastener #4A at 12" o.c.
2. Field notch back legs of NuWall® panel 1½" to fit over back leg of base trim.

DETAILS

TYPICAL DETAILS - NEW CONSTRUCTION PANEL ATTACHMENT

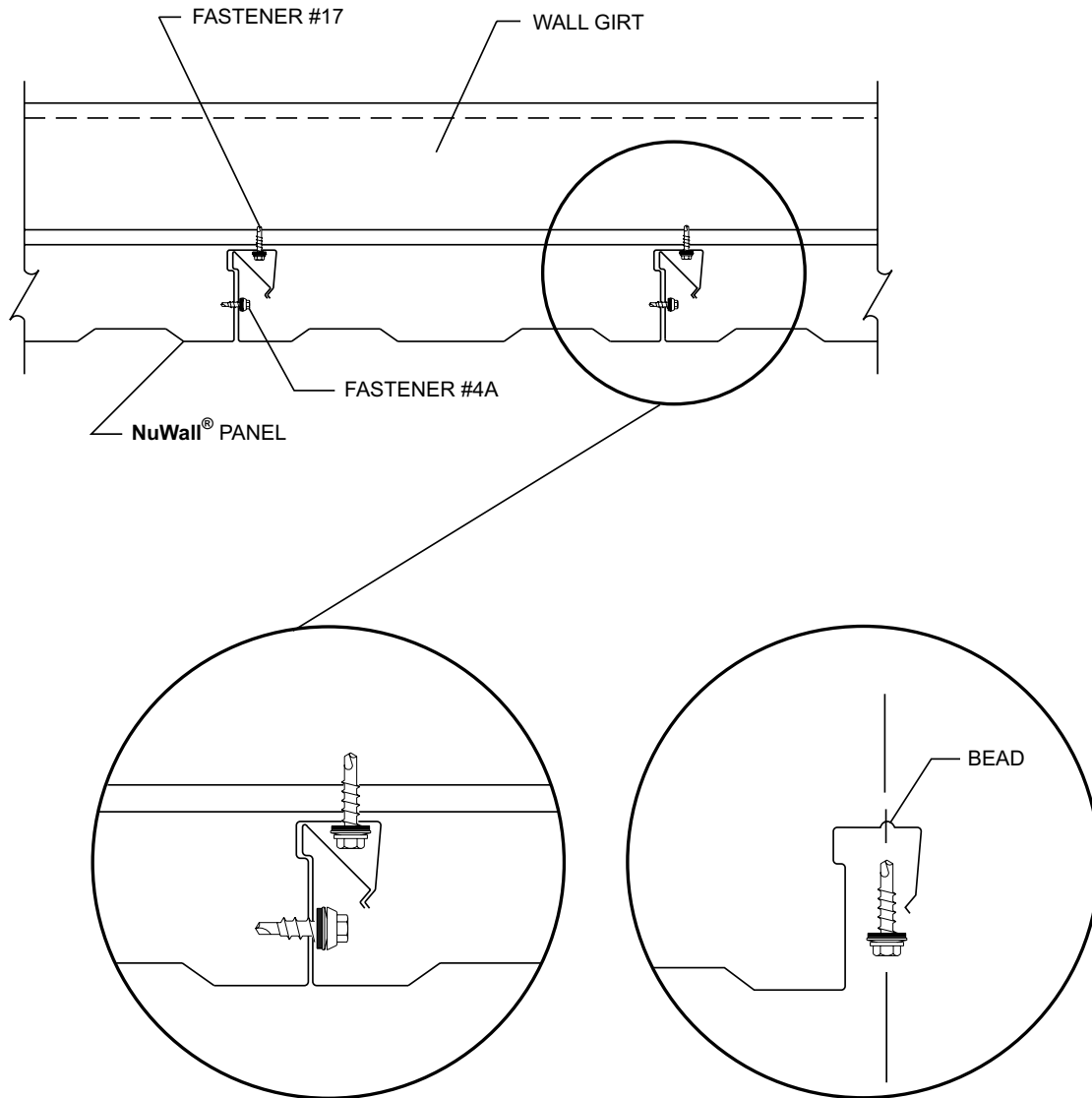

FASTENER LOCATION

NOTES:

1. Attach **NuWall®** panel to girts with Fastener #17. Install **NuWall®** fastener in the bead of the female rib of panel.
2. Install Fastener #4A horizontally through the seams of the **NuWall®** panels at the top and bottom of the panels.

DETAILS

TYPICAL DETAILS - NEW CONSTRUCTION DOOR HEAD/JAMB

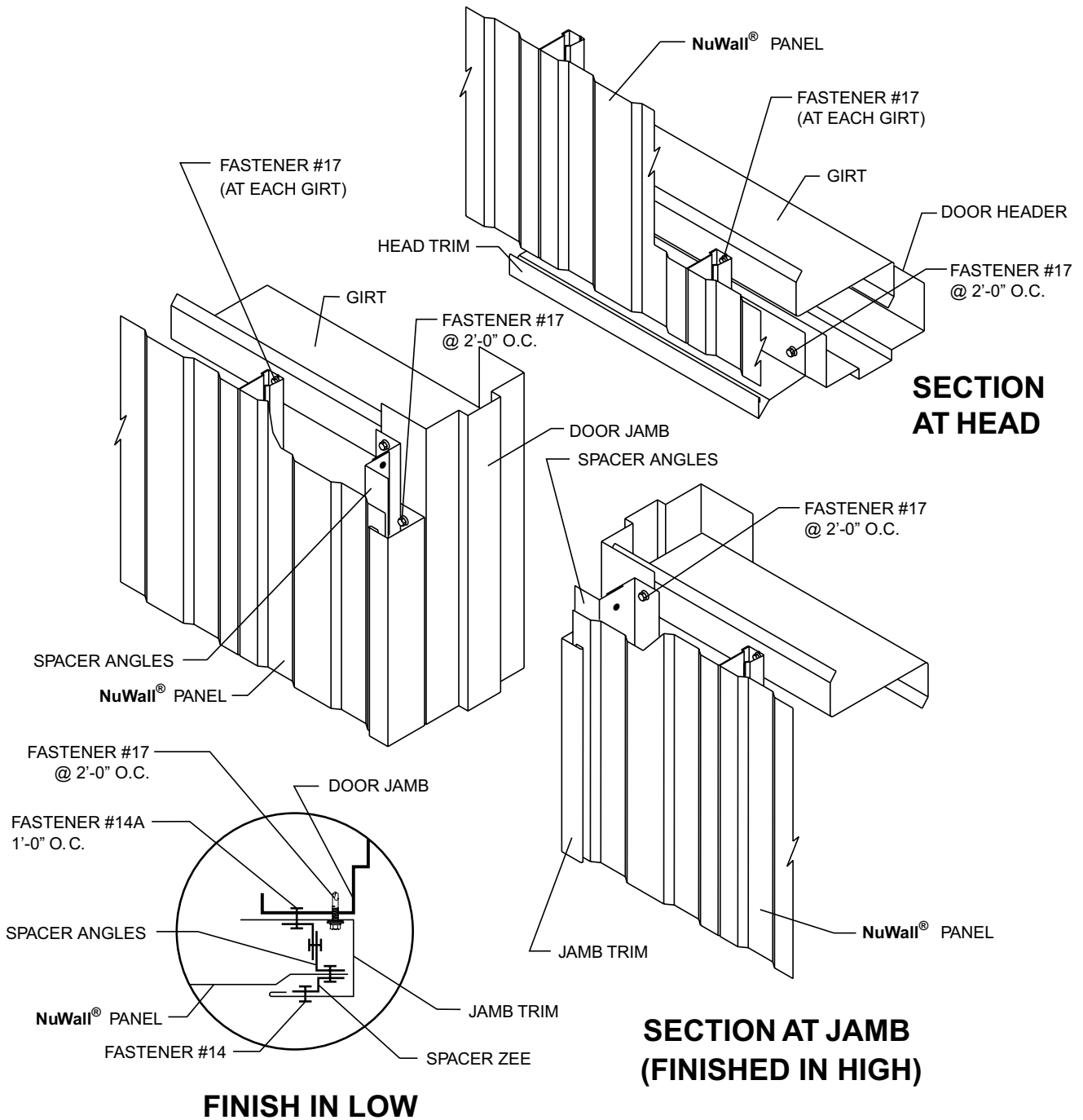

NOTES:

1. Attach head trim to girt with Fastener #17 at 2'- 0" o.c.
2. Attach spacer angles and spacer zee with Fastener #14 at 2'- 0" o.c.

DETAILS

TYPICAL DETAILS - NEW CONSTRUCTION WINDOW HEAD/SILL

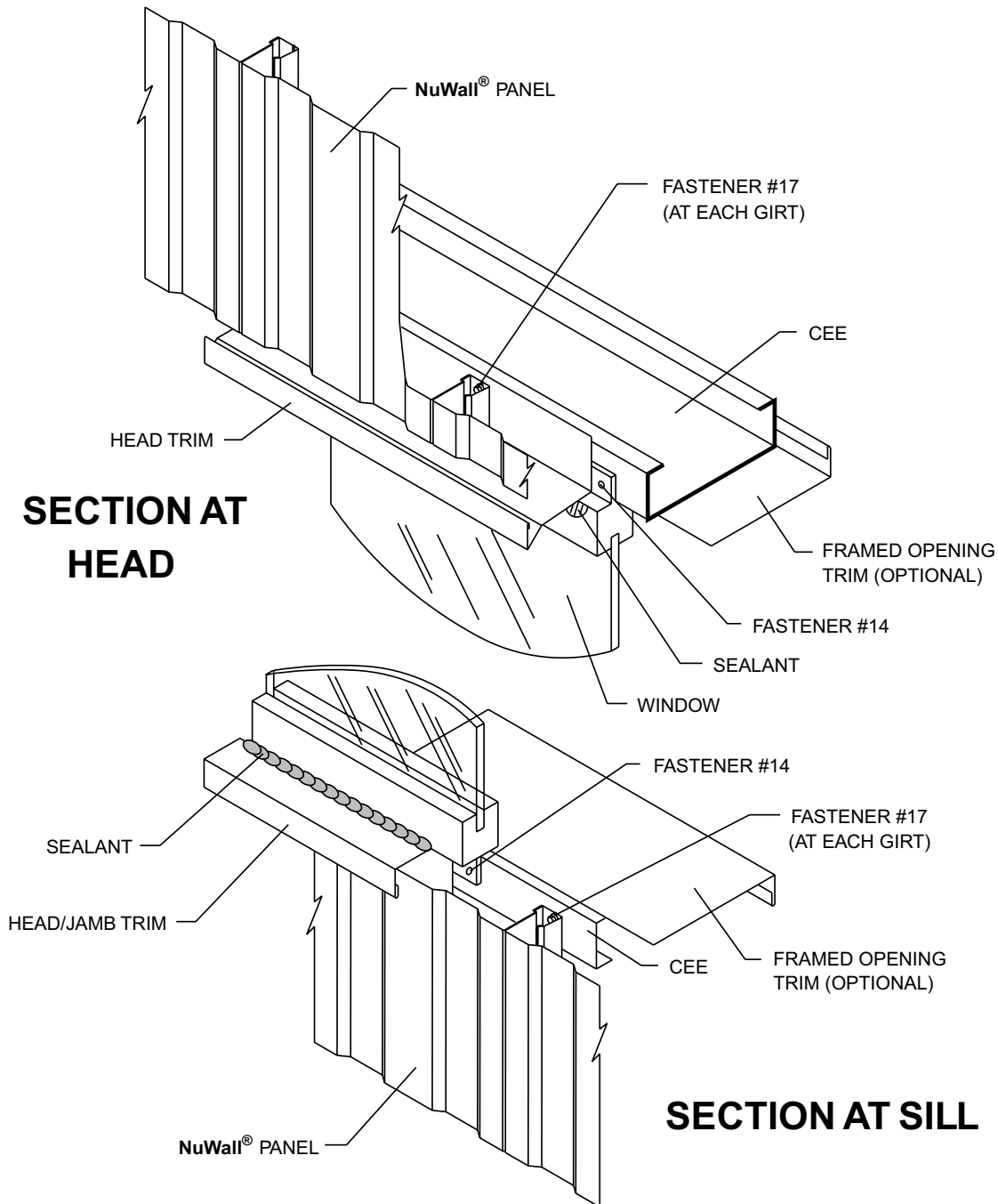

NOTES:

- 1. Attach head and Head/Jamb trim to window sill with a Fastener #17 at 2'-0" o.c.

DETAILS

TYPICAL DETAILS - NEW CONSTRUCTION WINDOW JAMB

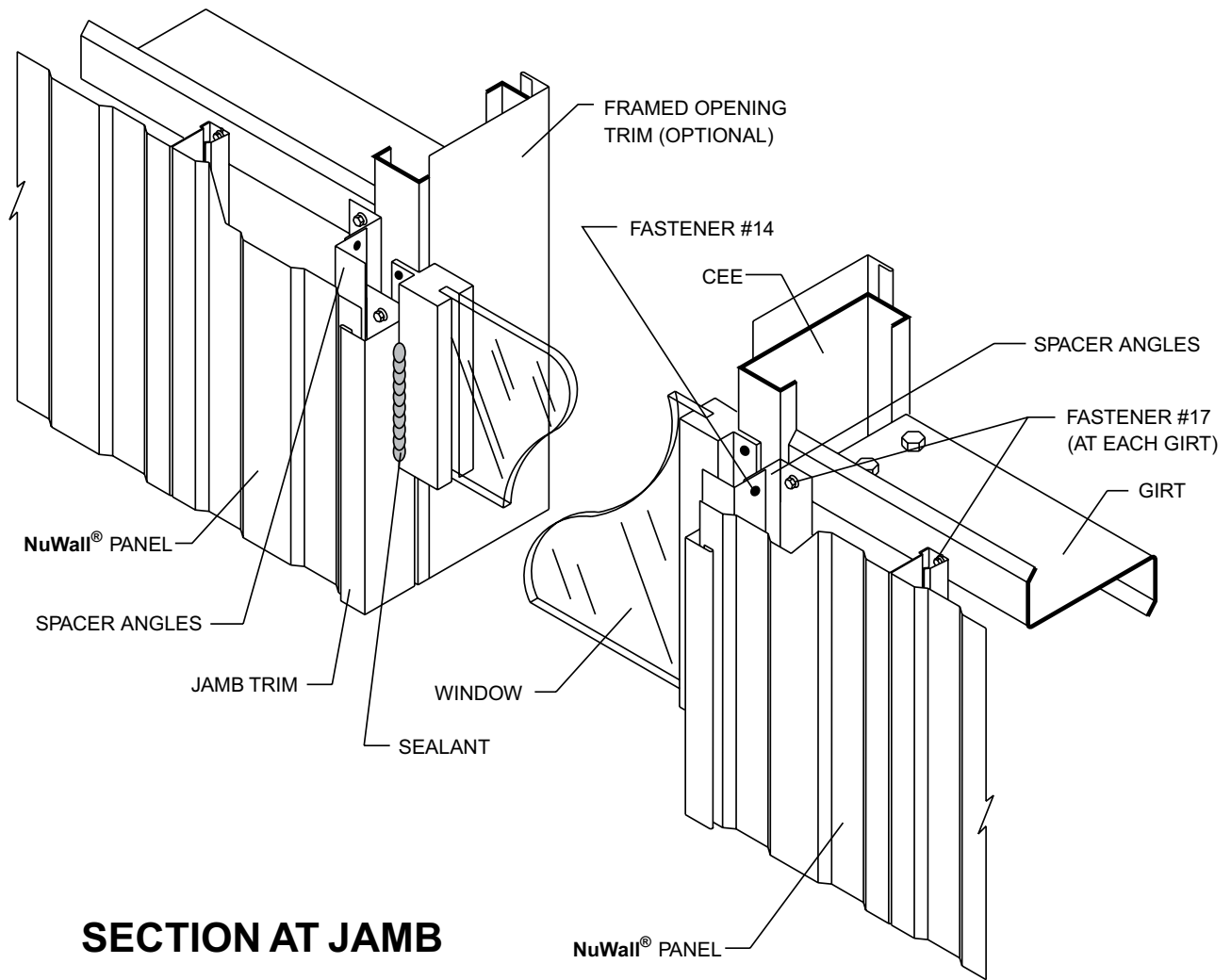

SECTION AT JAMB

NOTES:

1. Attach spacer angles and Head/Jamb trim to window jamb with a Fastener #17 at 2'-0" o.c.

DETAILS

TYPICAL DETAILS - NEW CONSTRUCTION OUTSIDE CORNER

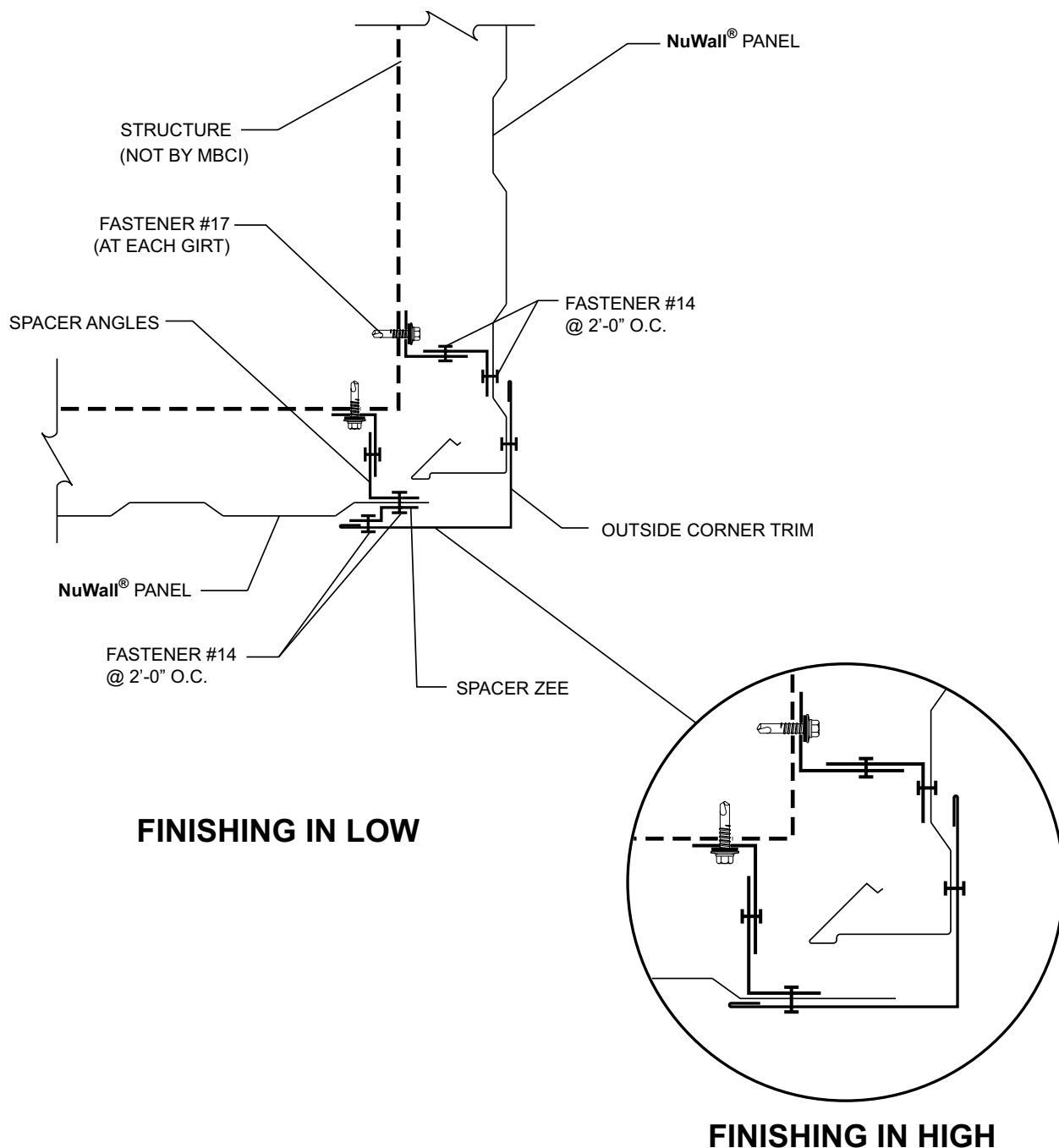

NOTES:

1. Attach spacer angles to structure with a Fastener #17 at each girt.
2. If required, attach spacer zee to panel with a Fastener #14 at 2'-0" o.c.
3. Attach corner trim to wall panel with Fastener #14 at 2'-0" o.c.

DETAILS

TYPICAL DETAILS - NEW CONSTRUCTION INSIDE CORNER

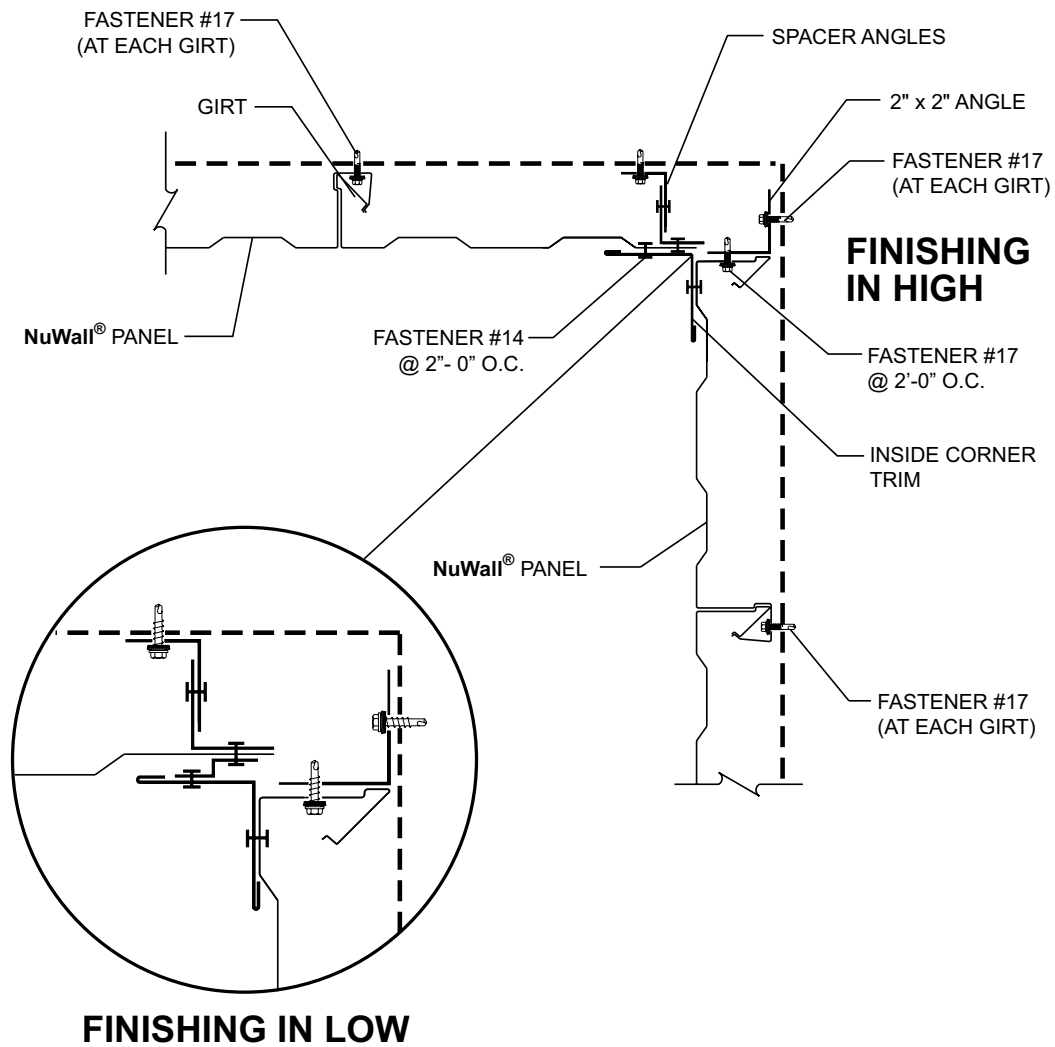

NOTES:

1. Attach spacer angles to structure with a Fastener #17 at each girt.
2. Field cut last panel as required and attach to spacer angles with Fastener #14 at 2'-0" o.c.
3. Attach male leg of starting panel to 2 x 2 angle at 5'-0" o.c.
4. Attach inside corner to panel with Fastener #14 at 2'-0" o.c.

DETAILS

TYPICAL DETAILS BASE

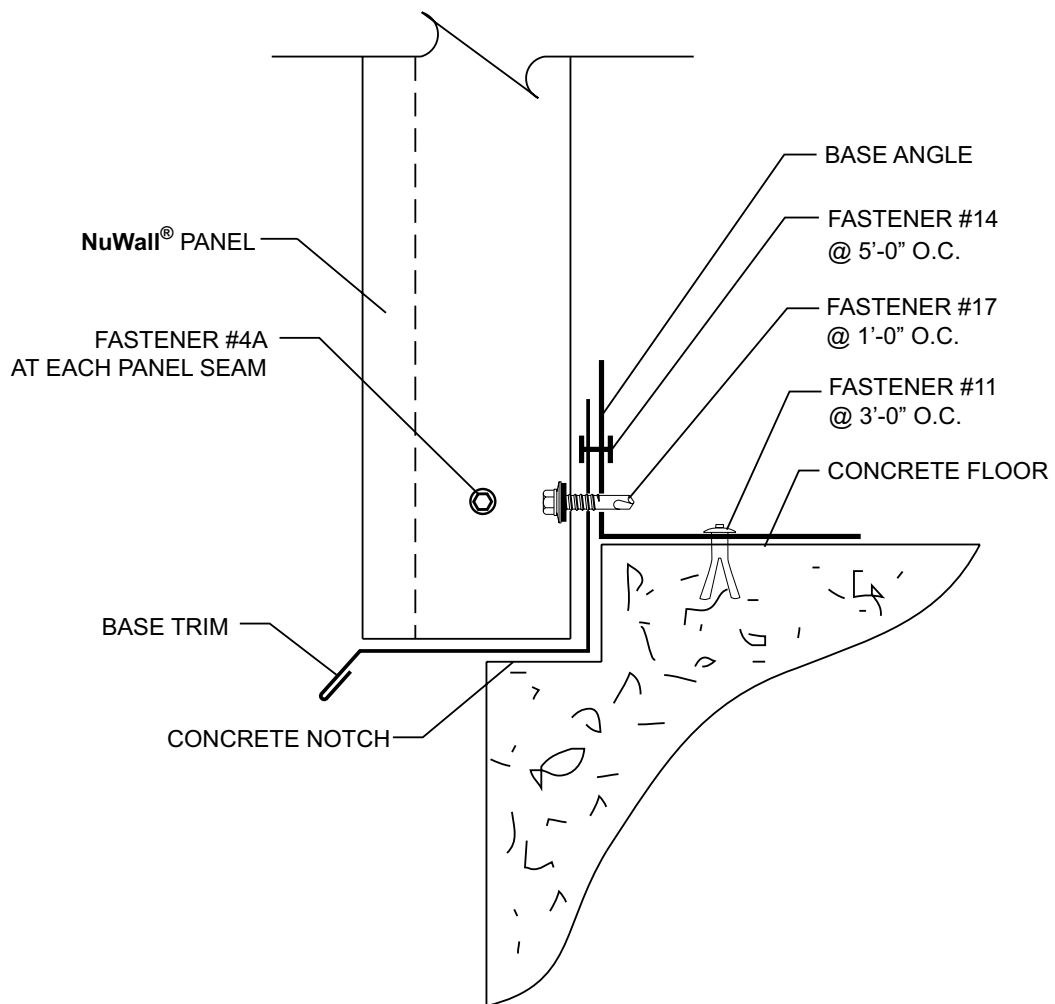

NOTES:

1. Attach base trim to base angle with two Fastener #14 to hold trim in place until panels are installed.



NuWALL®

NOTES

NOTES



Metal Roof and Wall Systems

For the most current information available, visit our Web site at www.mbc.com

Houston, TX
14031 West Hardy
P.O. Box 38217
Houston, TX 77238
281-407-6915

Adel, GA
1601 Rogers Road
P.O. Box 1107
Adel, GA 31620
888-514-6062

Atlanta, GA
2280 Monier Avenue
P.O. Box 44729
Atlanta, GA 30336
678-337-1619

Atwater, CA
550 Industry Way
P.O. Box 793
Atwater, CA 95301
209-445-3891

Ennis TX
1804 Jack McKay Blvd.
P.O. Box 1210
Ennis, TX 75120
469-256-8255

Indianapolis, IN
1780 McCall Drive
P.O. Box 657
Shelbyville, IN 46176
317-364-4329

Lubbock, TX
5711 East FM-40
P.O. Box 10133
Lubbock, TX 79408
806-224-2724

Memphis, TN
300 Highway 51 North
P.O. Box 366
Hernando, MS 38632
662-298-2337

Oklahoma City, OK
7000 S. Eastern Avenue
P.O. Box 95998
Oklahoma City, OK 73143
405-492-6968

Phoenix, AZ
660 South 91st Avenue
P.O. Box 739
Tolleson, AZ 85353
480-630-3022

Rome, NY
6168 State Route 233
P.O. Box 4141
Rome, NY 13442
315-371-4330

Salt Lake City, UT
1155 West 2300 North
P.O. Box 16027
Salt Lake City, UT 84116
385-715-2952

San Antonio, TX
8677 I-10 East
P.O. Box 69
Converse, TX 78109
210-888-9768

