

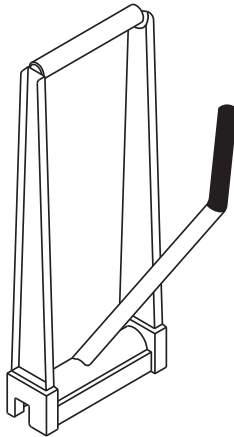

double-lok®

Field Seaming Tool Manual

EQUIPMENT CHECKLIST



**PHASE 1
CRIMPER**
(Use At Clip Locations Only)
Optional - Rented & Sent Separately

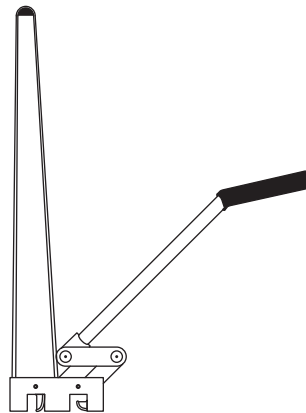

**PHASE 1 & 2
HAND TOOL**
Included With Electric Seamer

When handling the electric seamer tool, always use the handles to lift or pull it.
NEVER PICK IT UP BY THE LOCKING ARM OR PULL IT BY THE ELECTRIC CORD.

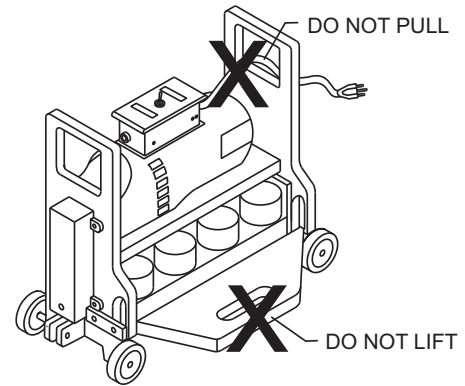

ERECTOR RESPONSIBILITY

This Seaming Equipment Kit was checked before shipment and found to be complete and in proper working condition. Upon receipt of this kit, inspect for any damage that may occurred during shipment. If any damage is discovered, call MBCI immediately for instructions.

It is the erector's responsibility to become familiar with, and operate the seaming equipment in accordance with the instructions provided in this manual using safe construction practices. Failure to adhere to these instructions could result in damage to the seaming equipment and/or roof panels, or injury to erection personnel.

SEAMER MANUAL

double-lok[®]

SEAMING OPERATION

CAUTION

Do not use the **PHASE 1 Crimper** to prepare panel seam for electric seamer. Damage to seams during electric seaming will result.

The use of a **PHASE 1 Crimper** can be used at clip locations to hold the panel seam together prior to seaming with the electric seamer. The **PHASE 1 Crimper** can be rented separately.

Set the **PHASE 1 Crimper** on the seam at clip location. Rotate the forming arm under the handle to provide 6" of **PHASE 1** seam.

CAUTION

It is critical that the panel seams are crimped and folded as shown before using the electric seamer. **Failure to follow these guidelines will result in damaged seams.**

To begin seaming with hand tool, set the hand tool on the seam making sure seam is in the **PHASE 1 Action** Slot. Align the edge of the hand tool with the end of the panel. Rotate the forming arm under the handle to produce 6" of **PHASE 1** seam. This should be done four times along the seam for a total of 24".

Return to the end of the panel to begin **PHASE 2 Action**. Set hand tool onto seam making sure seam is in the **PHASE 2 Action** slot. Align the edge of the hand tool with the end of the panel. Rotate the forming arm under the handle to produce 6" of finished **PHASE 2** seam. This should be done once per rib. **The relationship of this 6" of finished seam to the 24" of crimped seam is critical to the proper alignment of the tooling in the electric seamer.**

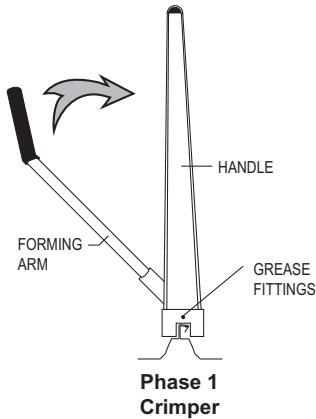

Beginning Phase 1 Crimp

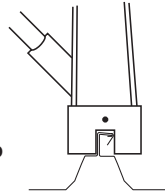

Finished Phase 1 Crimp

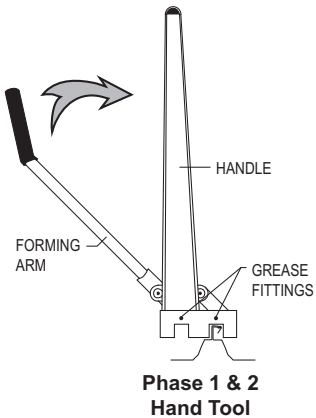
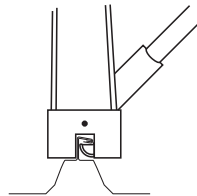

Beginning Phase 1 Action

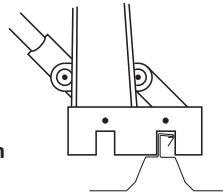

Finished Phase 1 Action

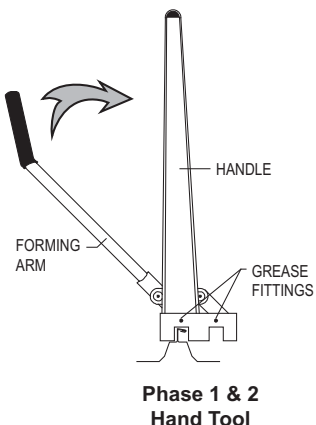
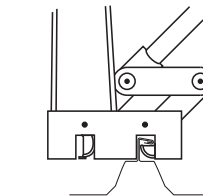

Beginning Phase 2 Action

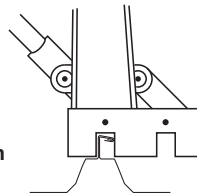

Finished Phase 2 Action

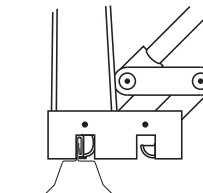

double-lok[®]

SEAMER MANUAL

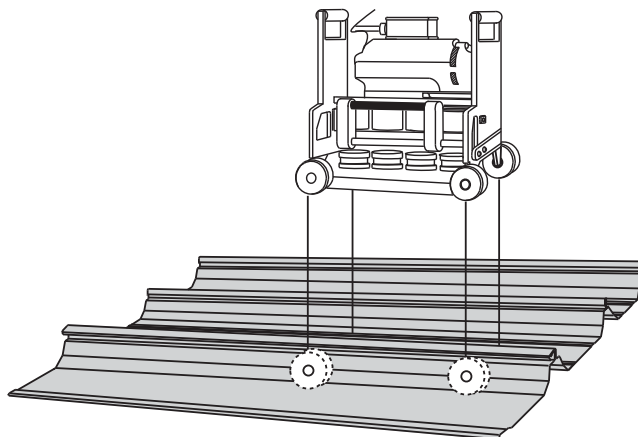
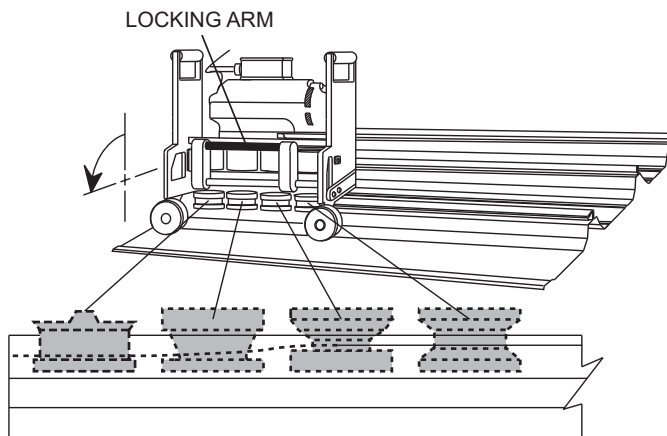
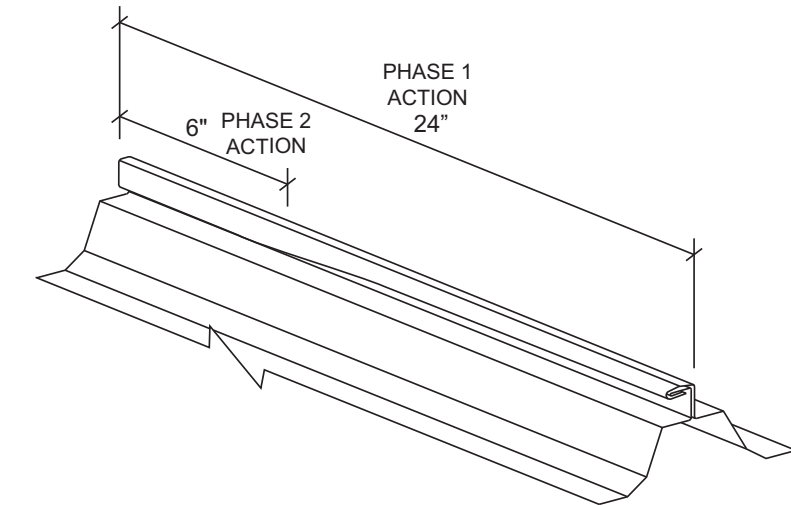

SEAMING OPERATION CONTINUED

The seam is now ready to accept the electric seamer.

Set seamer on seam with the locking arm up and to open side of the seam. The rear wheels should be at the edge of the panel.

Check to see that the last roll of the seamer is on the finished portion of the seam and the other rolls are on the crimped portion of the seam. Push the locking arm down to engage the rolls and turn the seamer on.

Note: While seamer is running, walk in front of seamer applying foot pressure to top of panel seam while paying attention to end of panel run.

CAUTION

Seamer motor is equipped with 15 amp circuit breaker. Extension cord wire size must be 10 gauge and no longer than 200' from power source.

MBCI will not be responsible for motor damage if above instructions are not adhered to.

CAUTION

Seamer operation should be closely supervised at all times. A safety line should be attached to the seamer.

Stop seamer about on foot from ridge. Disengage locking arm and remove the electric seamer.

Finish seam with hand tool by first crimping the remaining portion of female lip. Then, using the second stage of the hand tool, fold and finish the seam. Repeat this procedure for all panels.

SEAMER SPECIFICATIONS AND MAINTENANCE

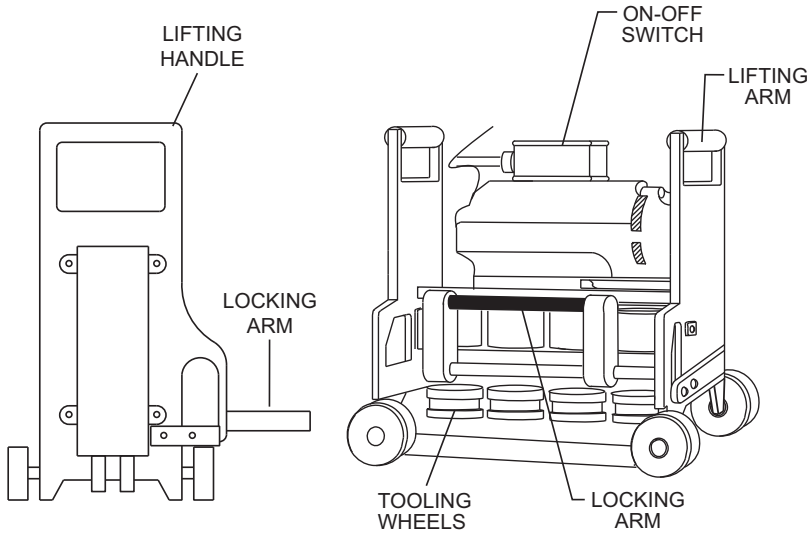

Seamer will seam 20 to 30 F.P.M. depending on gauge of panels and pitch of roof.

Seamer has 15 amp., 120 v., AC/DC motor.

Seamer should be cleaned with a nonflammable solvent, often, to prevent a build-up of galvalume or sealant on the rolls. **DO NOT SPILL CLEANING SOLVENT ON ROOF PANELS. THIS WILL VOID THE WARRANTIES ON THE ROOF PANELS FINISHES.**

Any adjustments, maintenance, modification, or repair not otherwise specifically set forth in this manual, must be conducted by MBCI.

If seamer motor should stop suddenly, check reset button located on the side of the electrical box on top of seamer motor. **CONTINUED RESETTNG OF MOTOR COULD BE INDICATIVE OF LOW VOLTAGE AND WILL CAUSE DAMAGE TO SEAMING MACHINE.** Check size and length of electric cords. If problem still persists, use an alternate power source.

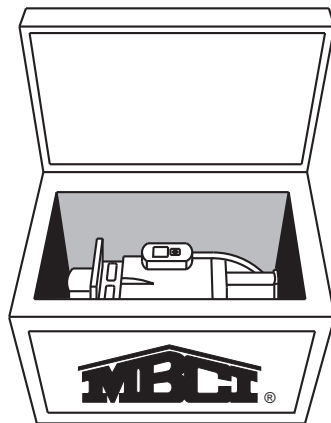

SHIPPING INSTRUCTIONS

Replace the seaming machine in the box. All items should be clean and in proper working condition. A \$50 minimum charge will be assessed for equipment improperly cleaned or damaged.

Return seamer as soon as you are finished. For seamer pick-up, please call FedEx Freight at 877-918-6012 extension #5091070. If possible, call the shipper the day before you are finished.

TOTAL SHIPPING WEIGHT — 167 LBS.
(Electric Seamer & Phase I/Phase II)

Phase I Hand Tool Shipping Weight - 12 LBS.

DESCRIPTIONS AND SPECIFICATIONS CONTAINED HEREIN WERE IN EFFECT AT THE TIME THIS PUBLICATION WAS APPROVED FOR PRINTING. In a continuing effort to refine and improve products, MBCI reserves the right to discontinue products at any time or change specifications and/or designs without incurring obligation. **To insure you have the latest information available, please inquire or visit our Web Site at www.mbc.com.**

Application details are for illustration purposes only and may not be appropriate for all environmental conditions, building designs, or panel profiles. Projects should be engineered to conform to applicable building codes, regulations, and accepted industry practices. Insulation is not shown in these details for clarity. **If there is a conflict between this manual and the erection drawings, the erection drawings will take precedence.**



For the most current information available, visit our Web Site at www.mbc.com

Houston, TX
14031 West Hardy
P.O. Box 38217
Houston, TX 77238
877-713-6224

Adel, GA
1601 Rogers Road
P.O. Box 1107
Adel, GA 31620
888-446-6224

Atlanta, GA
2280 Monier Avenue
P.O. Box 44729
Atlanta, GA 30336
877-512-6224

Atwater, CA
550 Industry Way
P.O. Box 793
Atwater, CA 95301
800-829-9324

Dallas, TX
1804 Jack McKay Blvd.
P.O. Box 1210
Ennis, TX 75120
800-653-6224

Indianapolis, IN
1780 McCall Drive
P.O. Box 657
Shelbyville, IN 46176
800-753-6224

Jackson, MS
201 Apache Drive
P.O. Box 720100
Jackson, MS 39272
800-622-4136

Lubbock, TX
5711 East FM-40
P.O. Box 10133
Lubbock, TX 79408
800-758-6224

Memphis, TN
300 Highway 51 North
P.O. Box 366
Hernando, MS 38632
800-206-6224

Oklahoma City, OK
7000 S. Eastern Avenue
P.O. Box 95998
Oklahoma City, OK 73143
800-597-6224

Omaha, NE
1011 Ellison Avenue
Omaha, NE 68119
800-458-6224

Phoenix, AZ
660 South 91st Avenue
P.O. Box 739
Tolleson, AZ 85353
888-533-6224

Richmond, VA
801 South Avenue
P.O. Box 239
Colonial Heights, VA 23834
800-729-6224

Rome, NY
6168 State Route 233
P.O. Box 4141
Rome, NY 13442
800-559-6224

Salt Lake City, UT
1155 West 2300 North
P.O. Box 16027
Salt Lake City, UT 84116
800-874-2404

San Antonio, TX
8677 I-10 East
P.O. Box 69
Converse, TX 78109
800-598-6224